

# The Importance of Gun Balancing in Monitor Calibration

Gary W. Meyer

CIS-TR-90-06  
February 27, 1990

## Abstract

The transformation from the *RGB* primaries of a television monitor to the *CIE XYZ* color notation system is usually formulated as a three by three matrix applied to a one by three vector. In the general case, however, this is not true because the black point of the monitor gamut is displaced from the origin of *CIE XYZ* space. An affine transformation is necessary to accommodate this translation of the monitor gamut, and this affine transformation can be reformulated as a four by three matrix times a one by four vector. Balancing the monitor guns so that they maintain the same luminance ratio over their entire dynamic range can minimize the error of assuming a three by three transform when a four by three matrix is actually called for. This procedure also leads to improved calibration for applications where the front panel brightness and contrast controls will be adjusted.

The technique of balancing the monitor guns has been employed in the broadcast television industry for many years. This paper presents the theory to support the validity of this approach. First, the affine transformation that is necessary to fully characterize the *RGB* to *CIE XYZ* transformation is developed. Next, colorimetric errors are identified for balanced and unbalanced monitors when the assumption of a simple three by three matrix transform is made. Finally, the effect on both balanced and unbalanced monitor gamuts of adjusting the front panel brightness and contrast controls is discussed.

Paper presented  
at the 1990 SPIE/SPSE Symposium on Electronic Imaging  
February 15-16, 1990

Department of Computer and Information Science  
University of Oregon

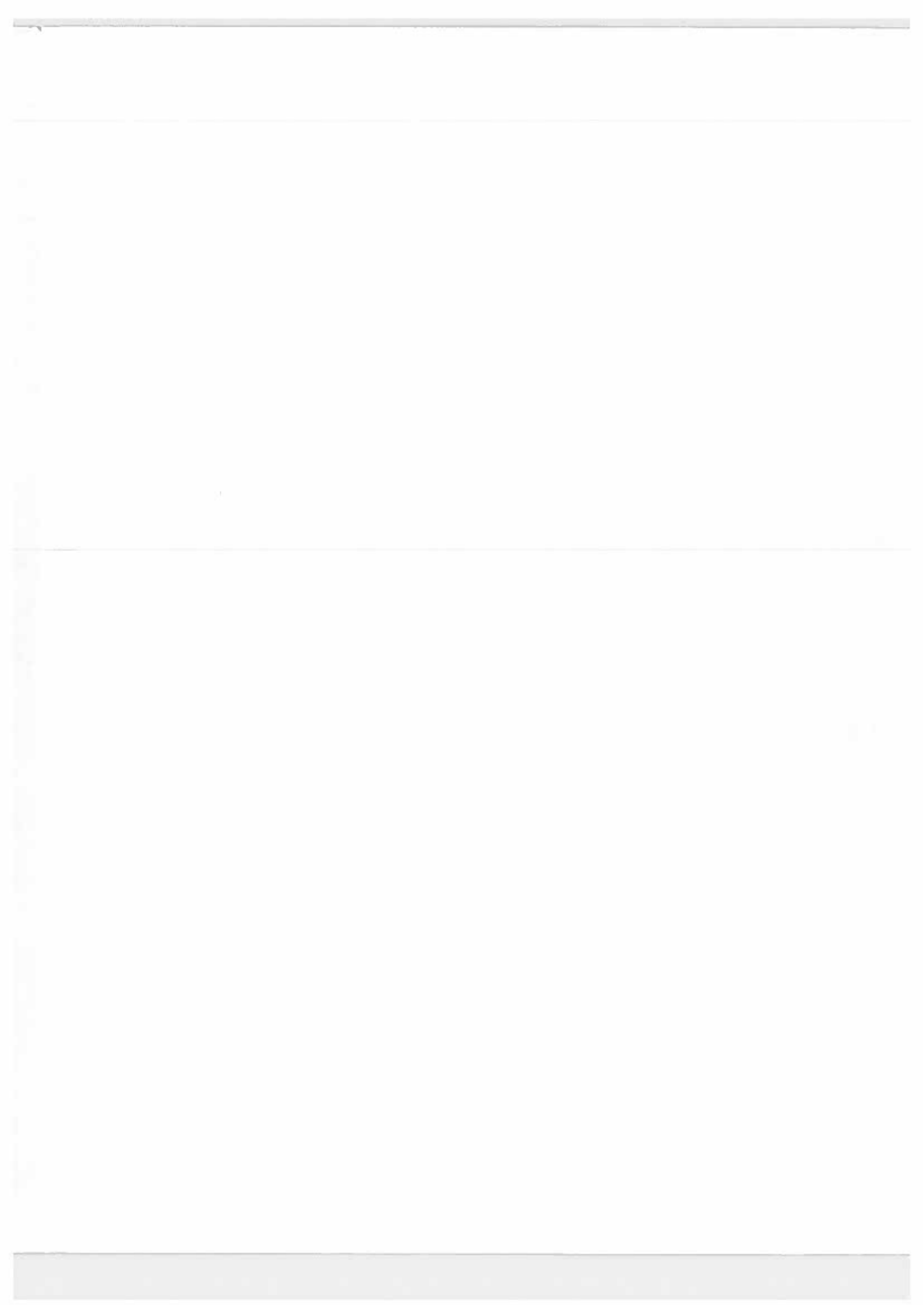

## The importance of gun balancing in monitor calibration

Gary W. Meyer

Department of Computer and Information Science  
University of Oregon  
Eugene, OR 97403

### ABSTRACT

The transformation from the *RGB* primaries of a television monitor to the CIE *XYZ* color notation system is usually formulated as a three by three matrix applied to a one by three vector. In the general case, however, this is not true because the black point of the monitor gamut is displaced from the origin of CIE *XYZ* space. An affine transformation is necessary to accommodate this translation of the monitor gamut, and this affine transformation can be reformulated as a four by three matrix times a one by four vector. Balancing the monitor guns so that they maintain the same luminance ratio over their entire dynamic range can minimize the error of assuming a three by three transform when a four by three matrix is actually called for. This procedure also leads to improved calibration for applications where the front panel brightness and contrast controls will be adjusted.

The technique of balancing the monitor guns has been employed in the broadcast television industry for many years.<sup>1</sup> This paper presents the theory to support the validity of this approach. First, the affine transformation that is necessary to fully characterize the *RGB* to CIE *XYZ* transformation is developed. Next, colorimetric errors are identified for balanced and unbalanced monitors when the assumption of a simple three by three matrix transform is made. Finally, the effect on both balanced and unbalanced monitor gamuts of adjusting the front panel brightness and contrast controls is discussed.

### 1. INTRODUCTION

A color television monitor being driven by a digital framebuffer can be a precise colorimetric device.<sup>2</sup> However, to take advantage of this precision the monitor must be carefully adjusted and calibrated. In this paper we talk about how to perform that calibration in terms of the CIE *XYZ* color notation system.

A tutorial presentation will be given of a basic calibration technique which is suitable for general computer graphic work. Particular emphasis is placed on the importance of properly balancing the monitor guns as part of the calibration process. This approach to monitor calibration treats the monitor as an additive color reproduction device that produces color by mixing the light from three independent light sources. As such, its colorimetric properties are determined by the simple transformation of primaries described in Section 2 of this paper and in any of the standard references on color science. For situations where this assumption may not be valid the techniques described by Cowan<sup>3</sup> may be more appropriate. We have adopted Cowan's notation scheme and terminology here.

### 2. MONITOR COLORIMETRY

The gamut of tristimulus values that a monitor can produce is established by the chromaticity coordinates  $x_a$  and  $y_a$  ( $a = R, G, \text{ or } B$ ) of the monitor phosphors. These can be determined by measurement using a spectroradiometer or by accepting the manufacturer's specifications for them. (Cowan and Rowell<sup>4</sup> show the variation that can exist between the chromaticity coordinates as specified for all monitors of a given model and the measurements taken from an individual monitor.) The monitor gamut is a triangle that connects these chromaticity coordinates on a chromaticity diagram. When the range of luminances possible for each chromaticity interior to the triangle is considered, the three dimensional chromaticity ( $x, y$ ) and luminance ( $Y$ ) diagram in Figure 1 results.

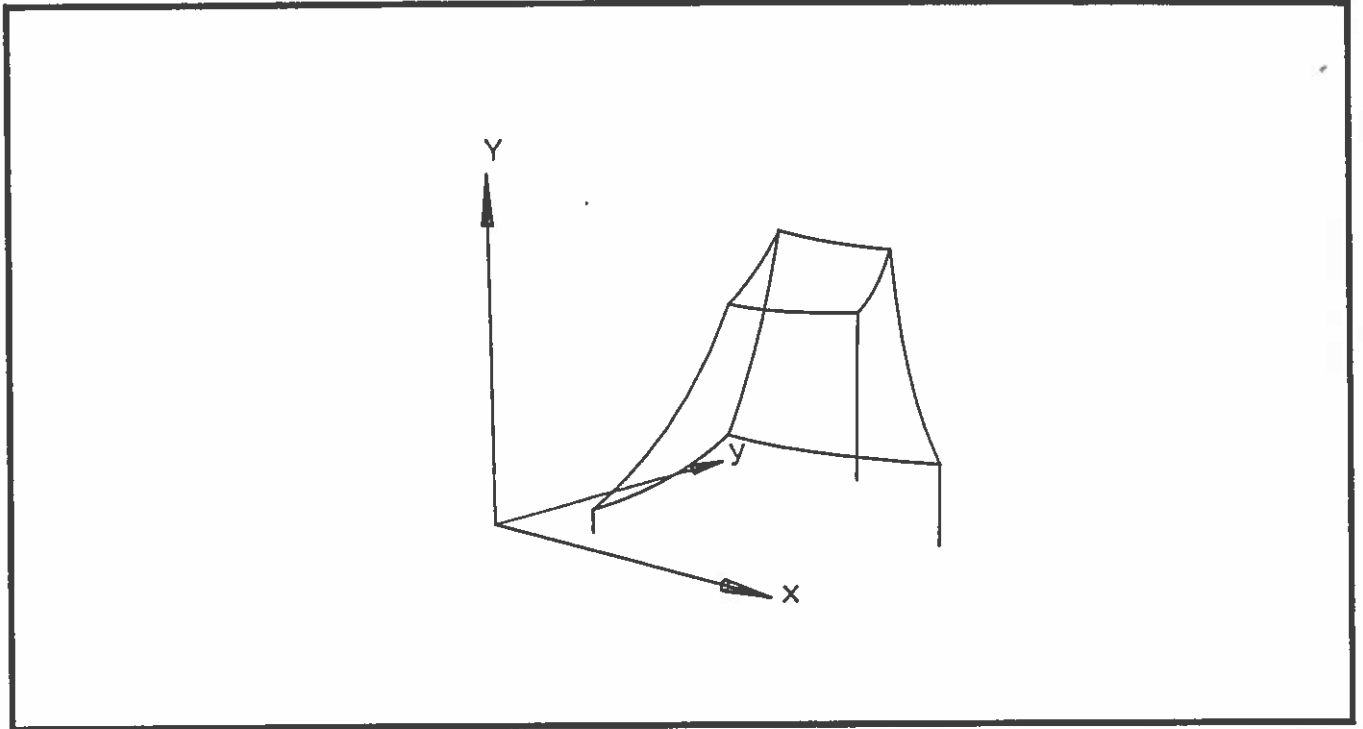

Figure 1: Monitor gamut on chromaticity and luminance diagram

For most computer controlled monitors, the voltages applied to the guns of the cathode ray tube are controlled indirectly via the digital values stored in a frame buffer. In this paper the gun voltages  $v_a$  ( $a = R, G, \text{ or } B$ ) refer to these frame buffer values and are assumed to lie on the range

$$0 \leq v_a \leq v_{amax}. \quad (1)$$

A typical color television monitor has individual controls to set the minimum and maximum amount of light that each of the red, green, and blue electron guns can produce. The names that are given to these two types of controls, the amount that they interact with each other, and the effect that they have on the *gamma* of each gun (in addition to establishing the range of light intensities possible) all vary somewhat from manufacturer to manufacturer. In this paper we will refer to these controls as the individual highlight and lowlight controls for each of the three guns. These controls are different from the brightness and contrast controls found on the front panel of most monitors which are used to adjust the dynamic range of the entire picture. The lowlight control for each individual gun determines the residual amount of phosphor excitation  $E_{0a}$  watts/cm<sup>2</sup> which will occur when  $v_a = 0$ . As  $v_a$  changes from 0 to  $v_{amax}$ , the phosphor excitation varies according to some unitless function  $e_a(v_a)$  normalized such that

$$0 \leq e_a(v_a) \leq 1. \quad (2)$$

This function is scaled by the factor  $N_a$  watts/cm<sup>2</sup> the value of which is determined by the setting of the highlight control for each individual gun. This leads to the overall phosphor excitation function  $E_a(v_a)$

$$E_a(v_a) = E_{0a} + N_a e_a(v_a) \quad (3)$$

which has units of watts/cm.<sup>2</sup>

There is a linear transformation that exists between the *RGB* monitor gamut and CIE *XYZ* space. This is a fundamental result of the color matching experiments that are the basis for color science. Given the chromaticity

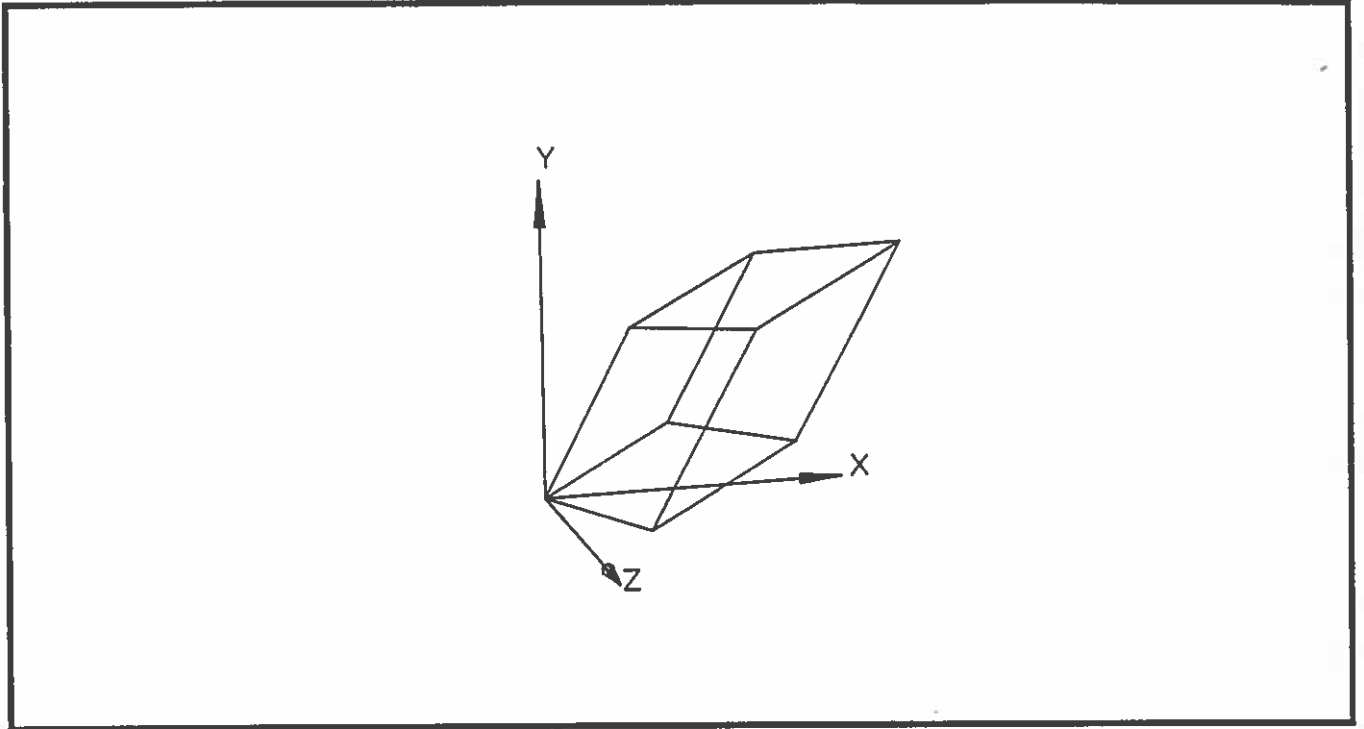

Figure 2: Monitor gamut in CIE XYZ space

coordinates  $x_a$  and  $y_a$  for the monitor phosphors, this transformation can be expressed in terms of the phosphor excitation function  $E_a(v_a)$  as

$$\begin{bmatrix} X \\ Y \\ Z \end{bmatrix} = \begin{bmatrix} x_R & x_G & x_B \\ y_R & y_G & y_B \\ z_R & z_G & z_B \end{bmatrix} \begin{bmatrix} E_R(v_R) \\ E_G(v_G) \\ E_B(v_B) \end{bmatrix} = \begin{bmatrix} & & \\ & M & \\ & & \end{bmatrix} \begin{bmatrix} E_R(v_R) \\ E_G(v_G) \\ E_B(v_B) \end{bmatrix}. \quad (4)$$

The result of applying Equation 4 to an *RGB* monitor gamut is shown in Figure 2.

The function  $e_a(v_a)$  can be determined by making measurements of the amount of light emitted by the screen for a range of input voltages  $v_a$ . The most appropriate fit to this data is often an expression of the form

$$e_a(v_a) = v_a^{\gamma_a}. \quad (5)$$

The exponent  $\gamma_a$  is usually on the range 2.0 to 2.5 and can be slightly different for each of the three guns. A possible phosphor excitation function is shown in Figure 3. Given a function of this form, equally spaced voltage increments produce the distribution of tristimulus values shown in Figure 4. Accurate *gamma correction* (as this is often referred to) requires the fitting of a higher order curve to the data or the use of table lookup.

The fact that a residual amount of phosphor excitation  $E_{0a}$  occurs even though  $v_a = 0$  means that the *black point* of the monitor gamut never actually sits at the origin of CIE XYZ space as it does in Figure 2. When a phosphor excitation function with  $E_{0a} \neq 0$  (see Figure 5) is substituted into Equation 4, the result is

$$\begin{bmatrix} X \\ Y \\ Z \end{bmatrix} = \begin{bmatrix} X_0 \\ Y_0 \\ Z_0 \end{bmatrix} + \begin{bmatrix} & & \\ & M & \\ & & \end{bmatrix} \begin{bmatrix} N_R e_R(v_R) \\ N_G e_G(v_G) \\ N_B e_B(v_B) \end{bmatrix} \quad (6)$$

where  $X_0$ ,  $Y_0$ , and  $Z_0$  are the tristimulus values for the monitor "black point" and are also the amount by which the monitor gamut has been translated away from the origin of CIE XYZ space. The position of a monitor gamut in

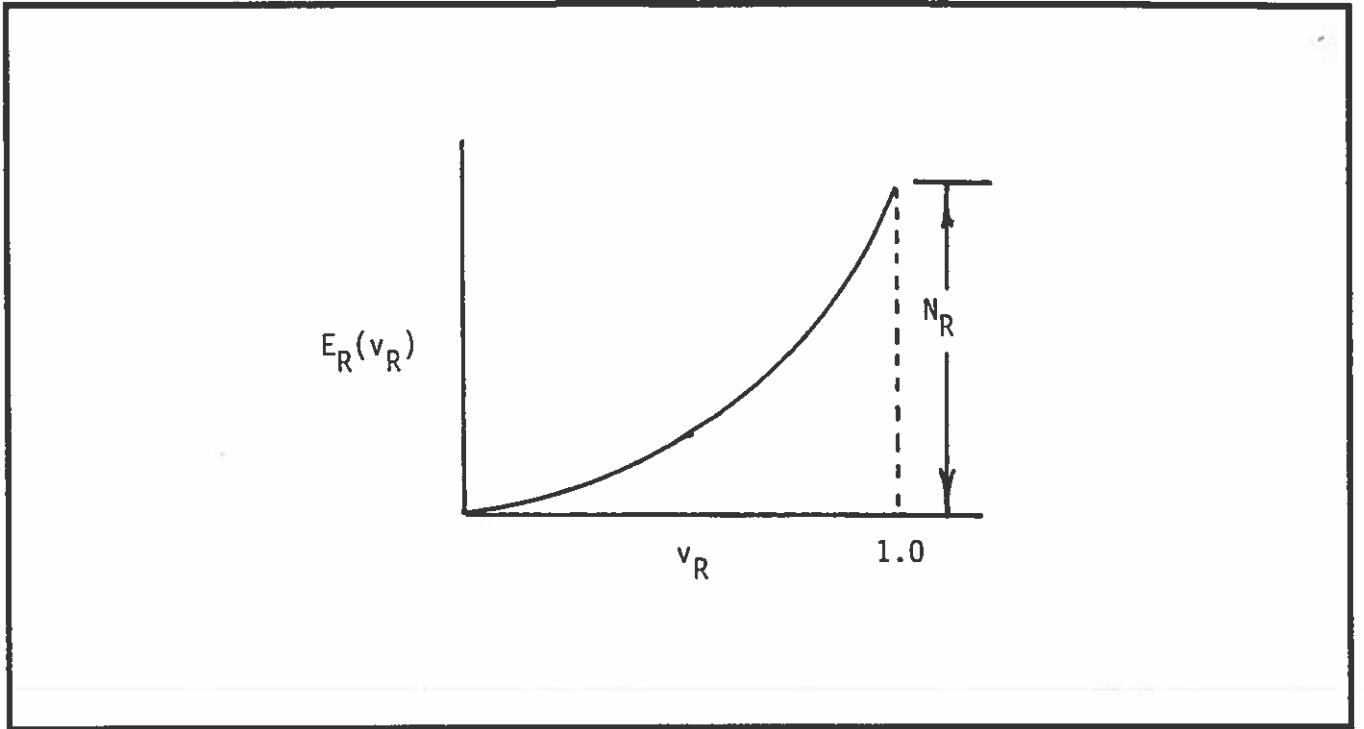

Figure 3: A typical phosphor excitation function

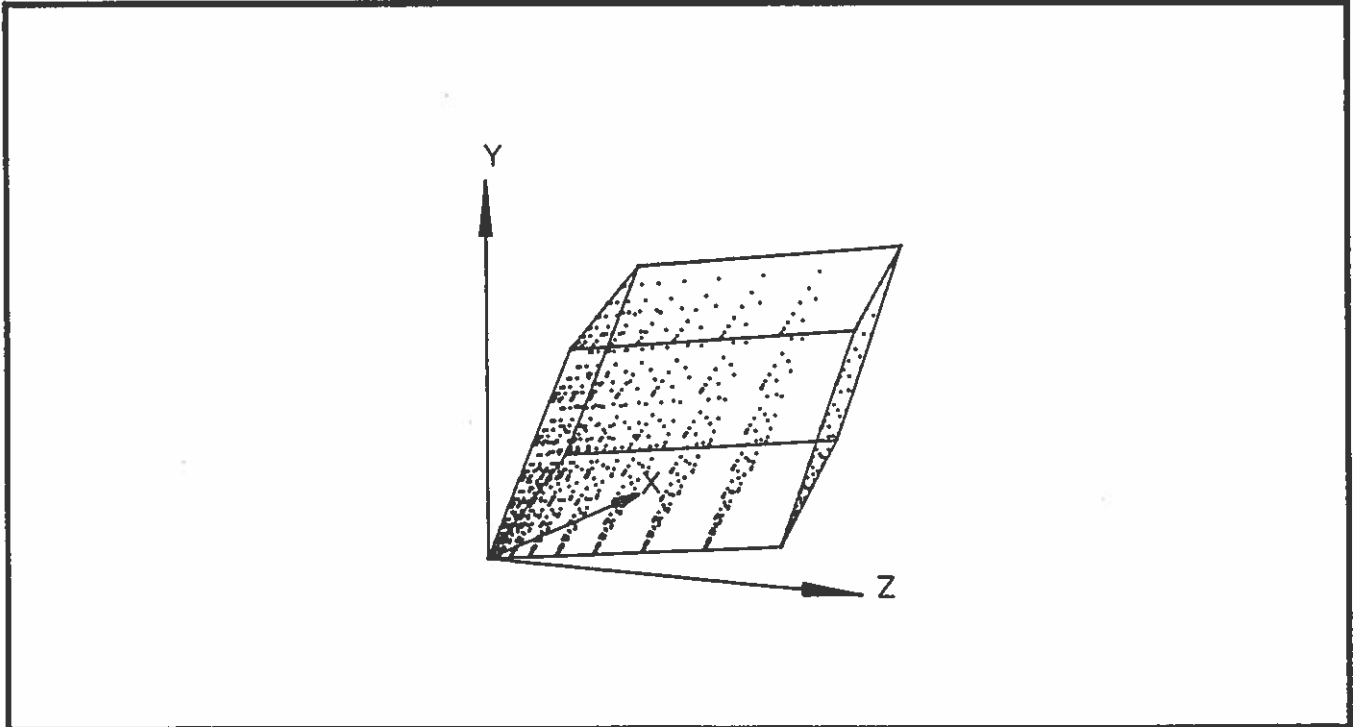

Figure 4: Distribution of tristimulus values produced by equally spaced voltage values

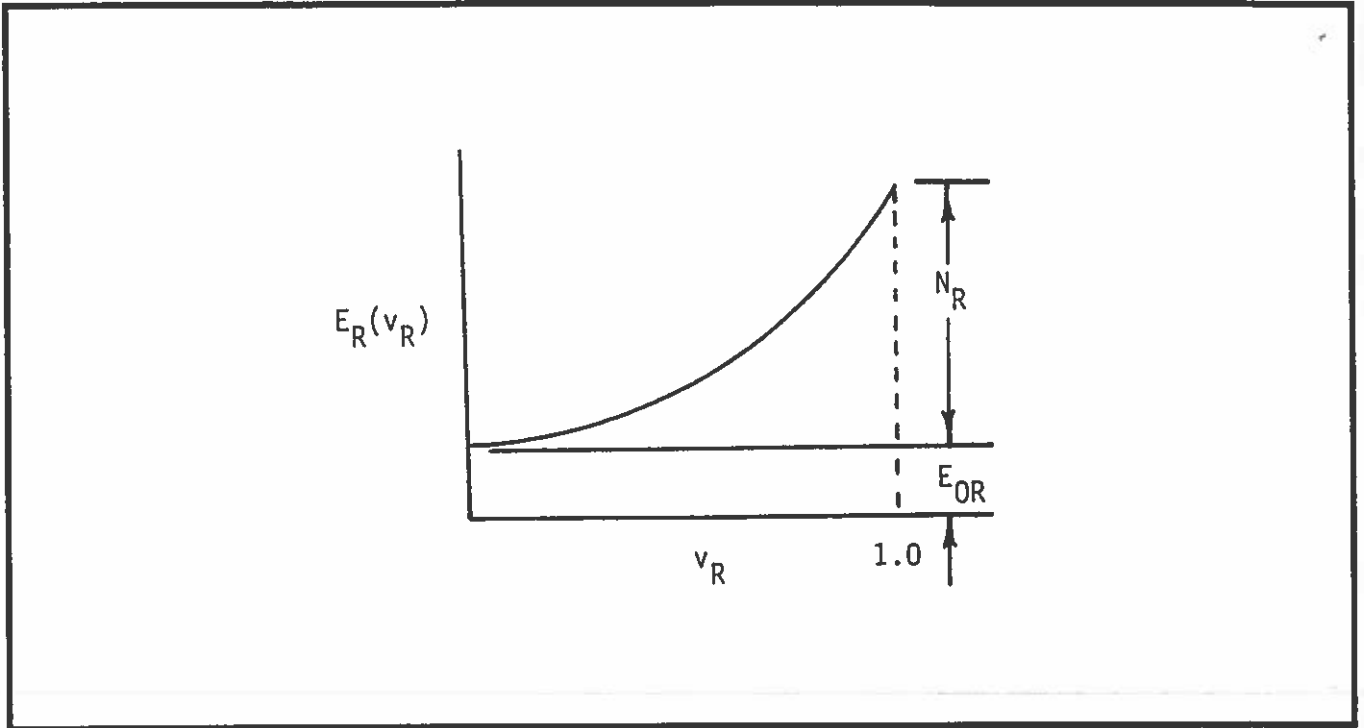

Figure 5: Phosphor excitation function which produces a residual amount of light when the  $v_R = 0$

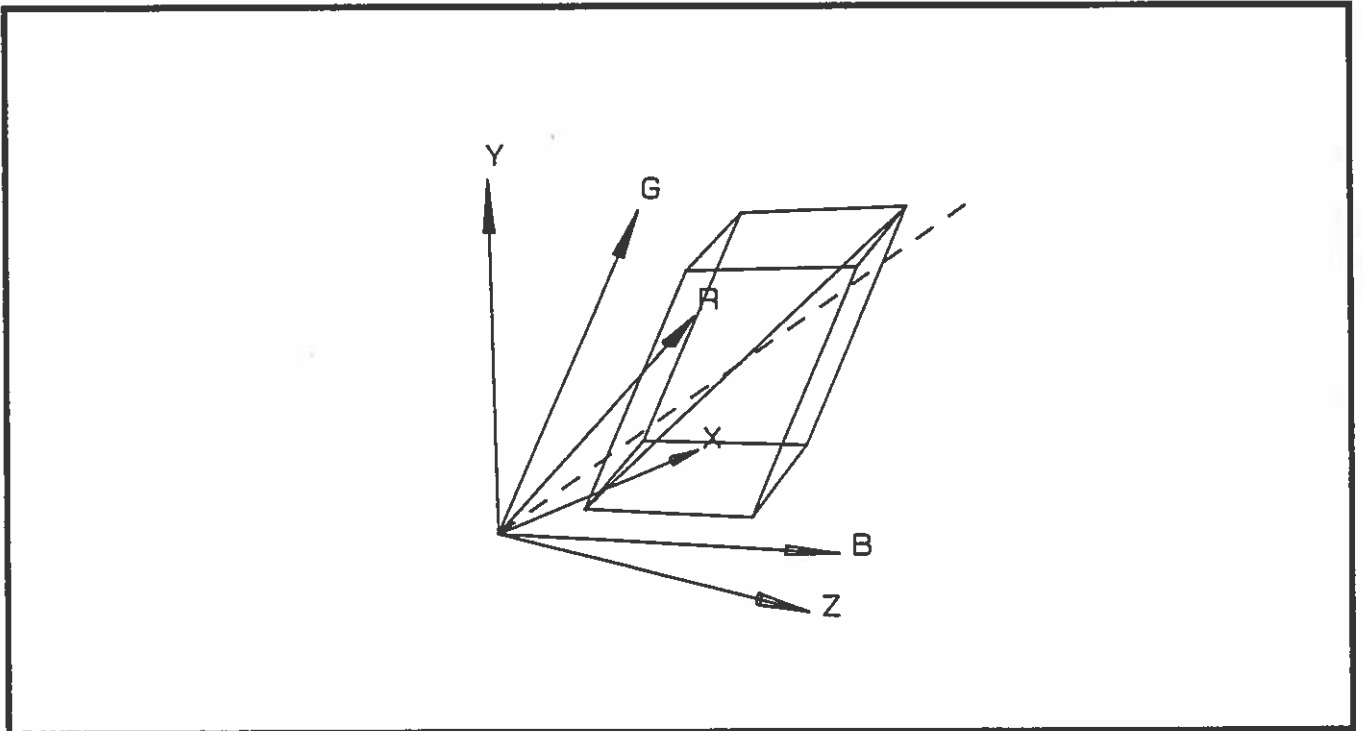

Figure 6: Gamut that results when monitor has not been balanced

CIE XYZ space for arbitrary values of  $N_R$ ,  $N_G$ ,  $N_B$ ,  $X_0$ ,  $Y_0$ , and  $Z_0$  is shown in Figure 6. Note that for an arbitrary white point and no balancing, the monitor diagonal is not coincident with a line through the origin of CIE XYZ space.

The affine transformation given in Equation 6 can be recast as a matrix times a vector by using a four by three matrix instead of a three by three matrix and by introducing a one as the fourth element in the right hand vector.

$$\begin{bmatrix} X \\ Y \\ Z \end{bmatrix} = \begin{bmatrix} x_R & x_G & x_B & X_0 \\ y_R & y_G & y_B & Y_0 \\ z_R & z_G & z_B & Z_0 \end{bmatrix} \begin{bmatrix} N_R e_R(v_R) \\ N_G e_G(v_G) \\ N_B e_B(v_B) \\ 1 \end{bmatrix} \quad (7)$$

This is a simplification of the approach taken in computer graphics where a complete switch is made to homogeneous coordinates. This level of generality requires the use of a four by four transformation matrix but it accommodates perspective projection in addition to translation.<sup>5</sup>

### 3. MONITOR CALIBRATION

Given that the monitor chromaticity coordinates are known, one approach to calibration accepts the monitor set up as it is and begins by determining the  $e_a(v_a)$ . A significant amount of research has been done on the nature of these functions and their independence.<sup>4,6,7,8</sup> In order to solve for  $N_R$ ,  $N_G$ ,  $N_B$ ,  $X_0$ ,  $Y_0$ , and  $Z_0$  in Equation 4 and complete the calibration, the voltages  $v_{a1}$ , and  $v_{a2}$  necessary to match two known colors with tristimulus values  $X_1$ ,  $Y_1$ ,  $Z_1$  and  $X_2$ ,  $Y_2$ ,  $Z_2$  must be measured. This can be done by using a luminance meter to measure the luminance which each gun produces at two different  $v_a$  settings, by using a colorimeter, or by using a color comparator to determine the  $v_a$  settings necessary to match the high and low intensity settings of a light source with known chromaticity. With these parameters established the calibration is complete.

It is often desirable, however, to have equal RGB values produce colors of roughly constant chromaticity. When this is the case, adjustments to the front panel brightness and contrast controls will not change the color of neutrals (although it will upset the gamma correction). As we shall see below, it also makes it reasonable to ignore the effect of the "black point" and simplify Equation 6. In the general case, however, the neutral diagonal of the monitor gamut does not lie on a constant chromaticity line through the origin of CIE XYZ space (see Figure 6). This makes it inappropriate to ignore the effect of the "black point" (as is often done) because both chromaticity and intensity differences are introduced by translating the origin of the monitor gamut to the origin of CIE XYZ space.

The calibration approach suggested here is to adjust the individual lowlight and highlight controls for the monitor guns so that the diagonal of the monitor gamut maintains constant chromaticity. Using the chromaticity and luminance form for tristimulus values, Equation 4 can be re-expressed as

$$Y \begin{bmatrix} x/y \\ 1 \\ z/y \end{bmatrix} = Y_0 \begin{bmatrix} x_0/y_0 \\ 1 \\ z_0/y_0 \end{bmatrix} + \begin{bmatrix} & & & \\ & & & \\ & & & \\ & & & M \end{bmatrix} \begin{bmatrix} N_R e_R(v_R) \\ N_G e_G(v_G) \\ N_B e_B(v_B) \end{bmatrix} \quad (8)$$

where the "black point" has luminance  $Y_0$ , and chromaticity coordinates  $x_0$ ,  $y_0$ , and  $z_0$ . A point on the diagonal of the monitor gamut has chromaticity coordinates  $x_D$ ,  $y_D$ , and  $z_D$ , has luminance  $Y_D$ , and is produced when

$$e_R(v_R) = e_G(v_G) = e_B(v_B) = d. \quad (9)$$

If the diagonal of the gamut has constant chromaticity, then the "black point" has the same chromaticity as the rest of the diagonal and Equation 8 can be reexpressed as

$$\begin{bmatrix} & & & \\ & & & \\ & & & \\ & & & M \end{bmatrix} \begin{bmatrix} N_R \\ N_G \\ N_B \end{bmatrix} = (Y_D - Y_0)/d \begin{bmatrix} x_D/y_D \\ 1 \\ z_D/y_D \end{bmatrix}. \quad (10)$$

The ratio between  $N_R$ ,  $N_G$ , and  $N_B$  can be solved for by setting the factor  $(Y_D - Y_0)/d$  equal to 1.0. The corresponding luminance ratios between the guns can then be found from

$$\frac{Y_G}{Y_R} = \frac{y_G N_G}{y_R N_R} \quad (11)$$



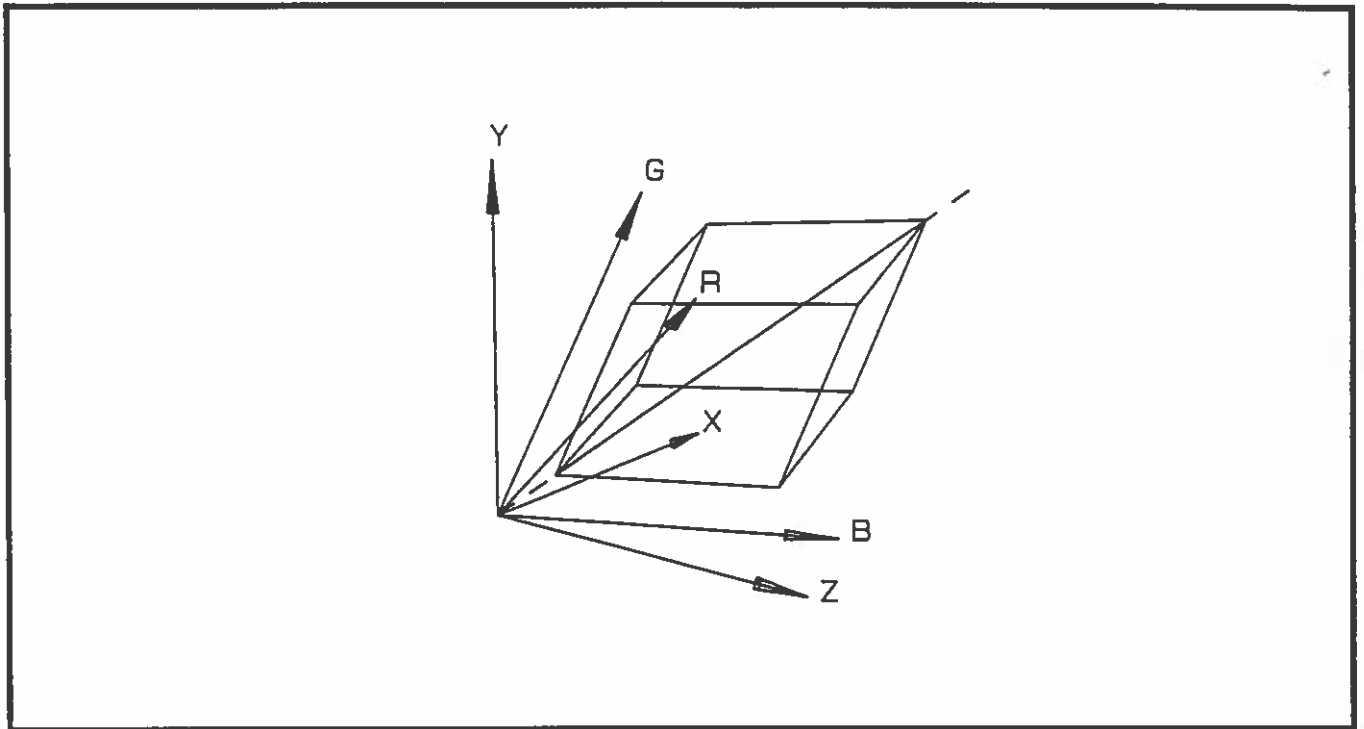

Figure 7: Gamut for a monitor that has been balanced

$$\frac{Y_B}{Y_R} = \frac{y_B N_B}{y_R N_R}$$

In the general case, an iterative procedure will be required to adjust the individual lowlight and highlight controls so that the desired ratio is maintained between the guns over their entire range. First, the functions  $e_a(v_a)$  must be measured for the initial setting of the monitor. Then voltages  $v_R$ ,  $v_G$ , and  $v_B$  can be selected such that Equation 9 holds. Using a luminance meter (or a radiance meter after determining the proportionality factor that relates luminance to radiance for each phosphor), the individual lowlight and highlight controls for each gun are adjusted so that the proper ratio between the three phosphor excitation functions is obtained at at least two different voltage settings. Adjusting the individual lowlight and highlight controls will cause the functions  $e_a(v_a)$  to change so these functions will have to be measured again and the process repeated. Because the final three functions  $e_a(v_a)$  which emerge from this process are so similar it is usually sufficient in practice to skip the initial measurement of the  $e_a(v_a)$  and do the first round of balancing for equal voltages. Then the  $e_a(v_a)$  can be measured, the balancing redone, and the process repeated until no further improvement is obtained. The gamut of a monitor which has been adjusted in the above manner is shown in Figure 7.

Changes to the contrast and brightness controls on the front panel of the monitor cause the "black point" and the "white point" to move along the monitor diagonal and produce expansions and contractions in the length and girth of the gamut. When the monitor has been properly balanced, neutral colors (those on the monitor diagonal) will remain on a line through the origin of CIE XYZ space and will thus maintain constant chromaticity (see Figure 7). The chromaticity shift for other colors in the monitor gamut is also minimized. This is in contrast to an unbalanced monitor (see Figure 6) where adjustments to the front panel brightness and contrast controls cause changes in the chromaticities of colors that lie on the monitor diagonal. Figure 8 shows how a line of constant chromaticity is affected by adjustments to the front panel controls of both a balanced and an unbalanced monitor.

To complete the calibration the luminance of the "black point,"  $Y_0$ , and "white point,"  $Y_W$ , must be measured.

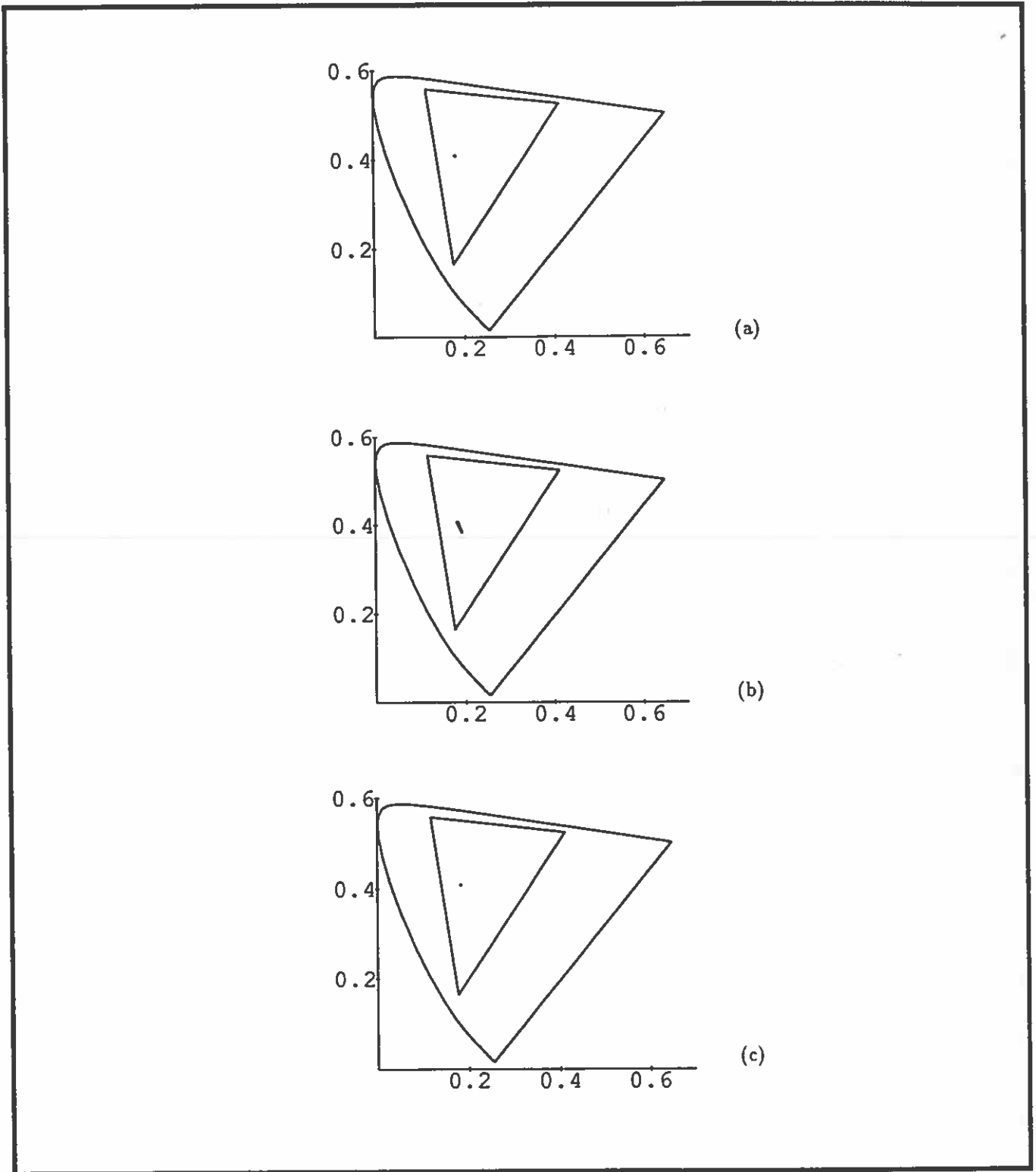

Figure 8: Points on a line with constant chromaticity (a) no longer have constant chromaticity when adjustments are made to an unbalanced monitor (b), but maintain constant chromaticity when the front panel controls of a balanced monitor are changed (c).

In practice it is difficult to measure  $Y_0$  because most luminance meters lack adequate sensitivity. One solution is to assume that  $Y_0$  is small enough to be zero. Because the monitor has been properly balanced, making this assumption slides the monitor gamut along a line with constant chromaticity until the tip of the gamut reaches the origin (see Figure 7). This primarily introduces intensity errors which in general are less objectionable than chromaticity shifts. Figure 9 shows how a constant luminance circle on the chromaticity diagram is shifted relative to its central neutral point when  $Y_0$  is ignored for both a balanced and an unbalanced monitor.

With the assumption that  $Y_0$  is negligible in size, Equation 6 becomes

$$\begin{bmatrix} X \\ Y \\ Z \end{bmatrix} = \begin{bmatrix} & & \\ & M & \\ & & \end{bmatrix} \begin{bmatrix} N_R e_R(v_R) \\ N_G e_G(v_G) \\ N_B e_B(v_B) \end{bmatrix}. \quad (12)$$

The "white point" of the monitor occurs when  $v_a = v_{amax}$  and

$$e_R(v_{Rmax}) = e_G(v_{Gmax}) = e_B(v_{Bmax}) = 1. \quad (13)$$

A luminance meter can be used to adjust the preset position for the contrast setting of the monitor (or the individual highlight controls while maintaining the proper ratio between  $N_R$ ,  $N_G$ , and  $N_B$ ) until  $Y = Y_W$ . If desired, the absolute magnitude of the normalization factors  $N_a$  can then be found from

$$\begin{bmatrix} & & \\ & M & \\ & & \end{bmatrix} \begin{bmatrix} N_R \\ N_G \\ N_B \end{bmatrix} = Y_W \begin{bmatrix} x_D/y_D \\ 1 \\ z_D/y_D \end{bmatrix}. \quad (14)$$

#### 4. CONCLUSIONS

An affine transformation is required to convert the *RGB* tristimulus values of a color television monitor into CIE *XYZ* space. This is necessary to accommodate the translation of the monitor gamut away from the origin of CIE *XYZ* space. This displacement of the monitor gamut is caused by the fact that a residual amount of light is emitted from the CRT even when the signal voltage drops to zero. A four by three matrix may be used to reexpress the affine transformation as the product of a matrix and a single four component vector.

Balancing the three monitor guns so that they maintain the same luminance ratio over their entire dynamic range can overcome some of the problems that are caused by the fact that the monitor transformation is affine. In the case where the residual amount of phosphor excitation must be set to a level that is significantly above threshold, balancing the monitor guns makes it possible to ignore the black point, use the traditional three by three matrix transform, and not induce chromaticity shifts. When the monitor is used in a situation where the front panel brightness and contrast controls will be adjusted, balancing the monitor guns minimizes changes in chromaticity produced by these elongations of the monitor gamut. The luminance ratios necessary to balance the monitor gamut for a particular chromaticity can be computed and can be set by using the appropriate equipment.

#### 5. ACKNOWLEDGEMENTS

The technique of establishing the proper gun ratios at two different points along the monitor diagonal was suggested to the author by Chris Odgers.

#### 6. REFERENCES

1. SMPTE, "Setting Chromaticity and Luminance of White for Color Television Monitors Using Shadow-Mask Picture Tubes," Recommended Practice RP71-1977, 1977.
2. Meyer, Gary W., and Greenberg, Donald P., "Perceptual Color Spaces for Computer Graphics," in *Color and the Computer*, H. John Durrett, ed., Academic Press, Boston, pp. 83-100, 1987.

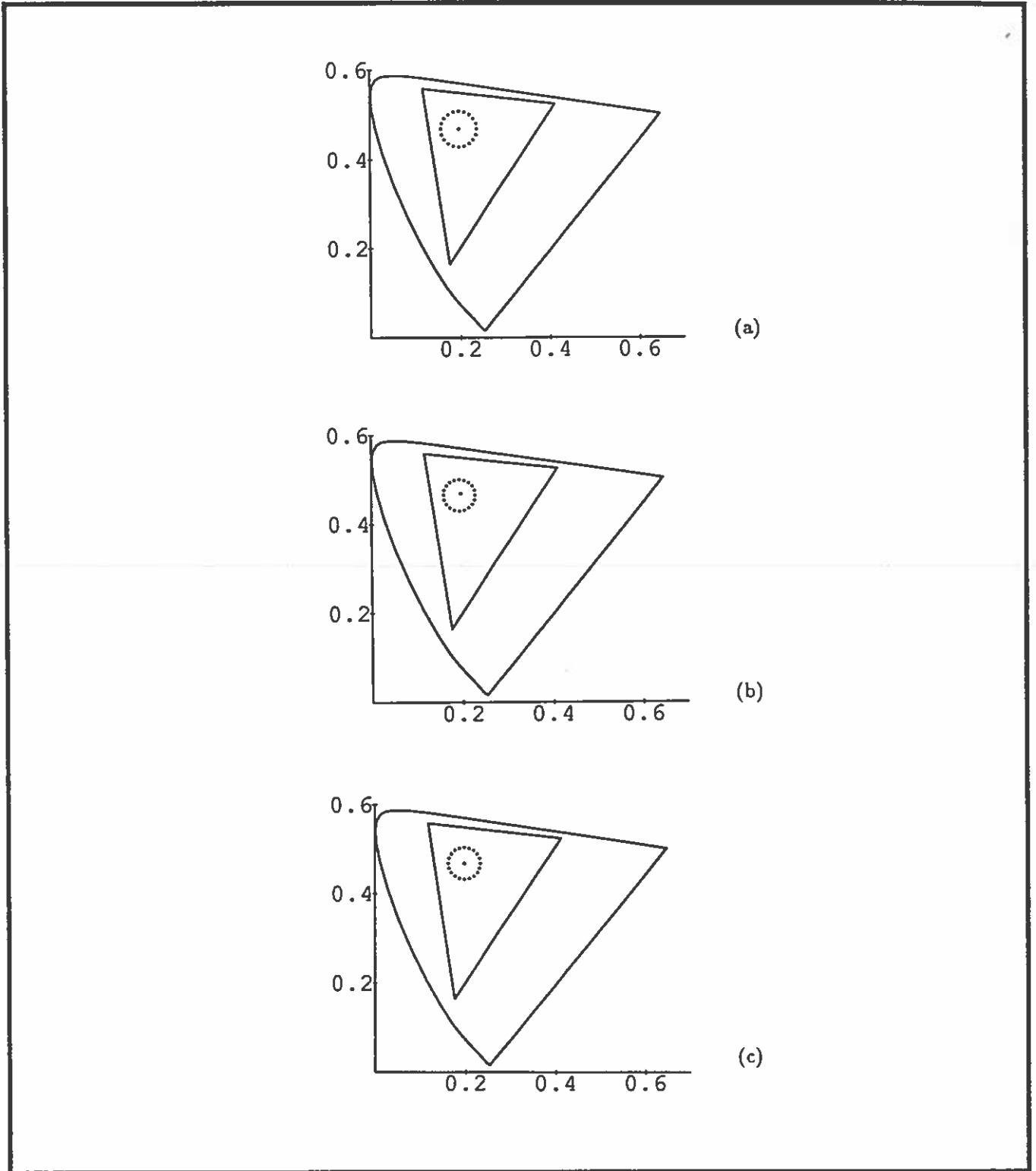

Figure 9: A constant luminance circle on a chromaticity diagram (a) is shifted relative to its central neutral point when  $Y_0$  is ignored on an unbalanced monitor (b), but remains centered about the central neutral point for a balanced monitor (c).

3. Cowan, William B., "Colorimetric Properties of Video Monitors," *Notes for OSA Short Course*, 1987.
4. Cowan, William B., and Rowell, Nelson, "On the Gun Independence and Phosphor Constancy of Colour Video Monitors," *Color Research and Application*, vol. 11, pp. S34-S38, 1986.
5. Newman, William M., and Sproull, Robert F., *Principles of Interactive Computer Graphics*, McGraw Hill, New York, 1979.
6. Cowan, William B., "An Inexpensive Scheme for Calibration of a Colour Monitor in Terms of CIE Standard Coordinates," *Computer Graphics*, vol. 17, pp. 315-321, 1983.
7. Brainard, David H., "Calibration of a Computer Controlled Color Monitor," *Color Research and Application*, vol. 14, pp. 23-34, 1989.
8. Post, David L., and Calhoun, Christopher S., "An Evaluation of Methods for Producing Desired Colors on CRT Monitors," *Color Research and Application*, vol. 14, pp. 172-186, 1989.