

**THE USE OF TELEOLOGY IN THE  
QUALITATIVE EVALUATION AND  
EXPLANATION OF CIRCULATORY  
SYSTEMS**

Keith Linn Downing

CIS-TR-90-13  
November 26, 1990

---

Department of Computer and Information Science  
University of Oregon

## ACKNOWLEDGEMENTS

I am very thankful for the assistance and prodding from my advisor, Sarah Douglas. She encouraged me to pursue this interdisciplinary research even when my own motivation was lacking.

I also owe quite a bit to Steve Fickas, who has supported me on research grants for many of my 7 years in grad school. Most of all, I and others greatly appreciate Steve's eagerness to go to bat for grad students.

Nils Peterson introduced me to cardiovascular systems, physiology and simulation at a time when I was floundering in blocks world. Call me a traitor, but hearts, arteries and kidneys beat big green pyramids hands down!

During my stay at Xerox PARC, I received considerable assistance from Jeff Shrager. I never thought that working until 4 a.m. could be such fun! Jeff was also incredibly helpful as a member of my dissertation committee. It's really nice to work with someone who basically considers himself a grad student with a real salary.

I also wish to thank Johan de Kleer, Pat Hayes and Richard Burton for their words of wisdom and general support during my stay at PARC.

Prakash Rao, Corey Morrell, Dave Meyer and Zheng Yang Liu all deserve much more than an acknowledgement for putting up with me as an officemate.

I also owe a thank you to Art Farley, Dan Udovic and Kartik Mithal for general assistance in getting this dissertation completed.

The biggest and most heart-felt "Thank you" goes to my mother, Nancy Downing. She has been a constant source of inspiration throughout my education, but particularly during the graduate school years when the task became so ominous. I thank her for all she has taught me, especially about being nice to people, which she only teaches by example.

Finally, I am lucky to have such a wonderful friend and companion, Målfrid Rustad. Her cheery disposition and general optimism made the more hellish phases of this endeavor more bearable and the pleasant aspects more enjoyable. As a special thanks to her, I will now perform an event that has been extremely rare during the past 8 months: cease writing and go home on time!

DEDICATION

to  
Mom,  
Gino,  
Bop  
and  
Mr. Grove

## ABSTRACT

This dissertation addresses a fundamental problem in the Artificial Intelligence field of qualitative physics: extending qualitative simulation and analysis to biological systems, and complex systems in general. A major problem in analyzing complex systems is the plethora of individual components and behaviors, which need to be organized into some coherent description of the working system. One way to conceptualize the myriad behaviors of a complex system is by applying knowledge of teleology (i.e. purpose).

Using the domain of circulatory physiology as an example, this dissertation integrates knowledge of structure, behavior and teleology to extract comprehensive explanations of complex systems. Circulatory physiology is a fruitful domain for teleological investigation for two important reasons: (1) unlike engineered artifacts, which generally have a single, well-documented purpose, biological systems admit many teleological interpretations, all of which may simultaneously apply, and (2) biological systems exhibit purposeful behavior when viewed from both the steady-state and dynamic perspective.

This dissertation formalizes both of these perspectives in a manner indigenous to computer simulation. It develops the Bipartite Teleology Model (BTM), which consists of four generic teleologies: transport, conservation, dissipation, and accumulation, along with a set of heuristics for evaluating a circulatory system's ability to satisfy these purposes during both steady-state and dynamic conditions. Furthermore, BTM provides guidance in the explanation of circulatory behaviors in terms of circulatory structure.

This dissertation describes The Biology Critic (BIOTIC), an implemented computer system which analyzes circulatory systems using BTM along with standard qualitative-simulation algorithms and a well-defined critical context. BIOTIC evaluates a circulatory system's ability to satisfy teleologies such as oxygen transport or heat conservation while the organism performs various activities in various environments. When run on qualitative models of reptilian and mammalian circulatory systems, BIOTIC produces critiques similar to those published by expert physiologists. Furthermore, BIOTIC can criticize a wide variety of existing and novel circulatory systems relative to many different contexts. These results support my central tenet that the combination of qualitative simulation and teleological interpretation suffices to produce intelligent analyses of complex biological systems.

## TABLE OF CONTENTS

INTRODUCTION .....	1
The General Explanation Problem.....	3
The "What" and "Why" of Physiological Criticism.....	4
Qualitative Physics meets Physiological Criticism.....	7
Teleology.....	10
Summary, Thesis Statement and Research Issues.....	19
Overview.....	20
 QUALITATIVE PHYSICS FUNDAMENTALS AND RELATED WORK.....	 21
The Fundamentals of Qualitative Physics.....	21
Three Representational Paradigms of Qualitative Physics.....	24
Teleology in Qualitative Physics.....	28
Summary.....	30
 THE BIPARTITE TELEOLOGY MODEL IN PRODUCER-CONSUMER NETWORKS .....	 32
Qualitative Producer-Consumer Networks.....	32
Formalized Topological Relationships.....	43
The Bipartite Teleology Model.....	45
Summary.....	53
 BIOTIC: THE BIOLOGY CRITIC.....	 54
Qualitative Simulation in BIOTIC.....	55
Criticism in BIOTIC.....	79
Summary.....	87
 BIOTIC IN ACTION.....	 88
Static Analysis of the Reptilian and Mammalian Circulations.....	 88
Regulatory Analysis of the Reptilian and Mammalian Circulations.....	 105
Summary.....	121

CRITIQUING THE BIOLOGY CRITIC.....	124
Burggren's Critiques.....	125
Local Physiologists' Critiques.....	128
Final Impressions.....	132
CONCLUSION.....	133
Primary Contributions.....	134
Research Questions Revisited.....	137
Future Research.....	151
BIBLIOGRAPHY .....	155
APPENDICES	
PRODUCER-CONSUMER TOPOLOGIES.....	161
Role Assignments for the Flow Topologies.....	161
Global Tissue Hierarchies.....	162
SUN-BASKING REPTILE.....	165
THE STRANGE TOPOLOGY.....	168
SERIALIZING THE REPTILIAN CIRCULATION.....	175

## CHAPTER I

### INTRODUCTION

Scientific discovery is not a one-way transfer of information from unambiguous nature to minds that are always open. It is a reciprocal interaction between a multifarious and confusing nature and minds sufficiently receptive (as many are not) to extract a weak but sensible pattern from the prevailing noise. -Stephen Jay Gould (1983)

This dissertation investigates the role of qualitative and teleological techniques during the analysis of physiological systems. Specifically, I employ qualitative simulation and teleological reasoning to automate the process of *circulatory criticism*: the evaluation of a circulatory system's behaviors and an explanation of those behaviors in terms of the system's structure.

This research lies within the field of qualitative physics (QP), which seeks to represent, simulate, diagnose and explain physical systems through symbolic, non-numeric techniques. Since expert physiologists tend to rely on qualitative and teleological concepts in their published critiques of circulatory systems, the obvious question from the qualitative physics standpoint is whether the simulation and reasoning behind these criticisms can proceed without detailed quantitative information.<sup>1</sup> I hypothesize that qualitative simulation and teleological reasoning are sufficient to produce circulatory criticisms similar to those proposed by the physiologists.

To test this claim, I have implemented BIOTIC, The Biology Critic. Given a qualitative circulatory model, environmental constraints, and a teleology, BIOTIC produces an evaluation of the model and an explanation of the contribution of its structure to its behavior and function. More concretely, it qualitatively evaluates a circulatory system's ability to satisfy *teleologies* (i.e., purposes) such as oxygen transport, carbon-dioxide removal or heat conservation while the organism performs activities such as running, swimming, or climbing in diverse environments such as a hot desert, a cold ocean or a high mountain. In so doing, BIOTIC illustrates the importance of a

---

<sup>1</sup>The difference between quantitative and qualitative approaches to simulation and reasoning is fundamentally a difference in numerical precision. Quantitative models involve integer or real-valued parameters whose actual values must all be known before the simulation can commence. Qualitative models represent parameter values as fairly-large ranges over the real numbers, ranges often bounded by crucial landmark values such as the boiling point of water or the speed of sound. Due to the nondeterminism of range arithmetic, qualitative simulation or *envisonment* often produces a set of possible behaviors (called *interpretations*), while quantitative simulators generally yield a single interpretation.

properly defined context for physical-system criticism, and, more generally, the vital role of teleology in scaling up qualitative physics to complex domains and tasks.

A major problem in analyzing complex systems is the plethora of components and behaviors, which need to be organized into some coherent description of the active system. I will refer to this as the *explanation problem*. Just as a human's behavior becomes more understandable when we know the underlying desires and can therefore interpret actions as pieces of a plan to achieve them, the myriad behaviors of a complex system begin to "mean something" when assessed relative to the purpose, function or *teleology* of that system. Teleological knowledge enables us to understand systems and to predict and explain their future actions.

Furthermore, teleology serves as a judgmental bias for criticizing physical systems: we can evaluate system behaviors (and the structures that enabled them) according to whether or not they fulfill the teleology. So, by translating purposes into expected behaviors, we can exploit teleological knowledge to discern "good" from "bad" behavior. Obviously, criticism demands such a standard; and physiological criticism demands a multiplicity of these standards to account for the wide variety of contexts in which physiological systems are evaluated.

This dissertation presents *The Bipartite Teleology Model (BTM)*, which facilitates the criticism of circulatory systems from two angles: the static and the dynamic. These perspectives embody two ways in which physiological systems go about achieving teleologies: via normal activity when in a stable environment, and via regulatory mechanisms when externally perturbed. Modelled after the dual perspectives of teleology evident in both philosophical and physiological interpretations of system behavior, BTM further clarifies the role of functional knowledge in the qualitative analysis of physical systems.

The BIOTIC project makes six basic contributions to qualitative physics:

1. It provides an operational model of bipartite teleology.
2. It illustrates the role of context in the analysis of physical systems.
3. It shows how teleology helps to focus the explanation process.
4. It thoroughly integrates structure, behavior and function.
5. It introduces the producer-consumer metaphor to qualitatively model flow-and-diffusion-based systems.
6. It helps fulfill qualitative physics' longstanding promise to education by providing the basis for a construction environment in which students can explore the relationships between topology, teleology and behavior in circulatory physiology.

In the remainder of this chapter, I will (a) discuss the general explanation problem as a motivator for research into general teleological models, (b) define circulatory criticism and discuss its appropriateness for the



exploration of teleological concerns in qualitative physics, (c) define teleology in the context of circulatory systems, (d) discuss the teleological differences between engineering and physiology, (e) define bipartite teleology and provide its philosophical and physiological underpinnings, and (f) present my thesis statement along with three relevant research questions addressed by this research.

### The General Explanation Problem

The general explanation problem is one of organizing the structures and behaviors of a complex physical system into a concise and comprehensive description. Computers need this ability in order to convey the most relevant aspects of a physical system to their operators and/or users, especially in real-time situations where computers must predict or monitor the behaviors of complex systems, such as nuclear plants, weather patterns or living organisms.

In part, the founding of the field of qualitative physics (QP) was motivated by the explanation problem. Quantitative simulators (i.e., *envisioners*) tend to produce a good deal of superfluous data and thus require considerable data interpretation to generate "presentable" results, which often contain primarily qualitative information and simple causal relationships. Qualitative physicists sought to bypass quantitative simulation and data interpretation by performing simulations over qualitative models. Ideally, the simulation results would then comprise presentable qualitative explanations. Unfortunately (as discussed more thoroughly in Chapter II), qualitative simulation often yields ambiguous results (i.e., many *interpretations*). Also, each interpretation contains many qualitative behaviors in need of parsing, since lengthy envisionment traces generally fail as explanations. Hence, qualitative physics alleviates part of the explanation problem by producing qualitative results, but its ambiguity can often exacerbate the problem; and a set of qualitative data still does not suffice as an explanation.

A major advance came in 1979, when de Kleer used teleological knowledge to both restrict the ambiguity of envisionment and parse interpretations into functional explanations. In this way, teleology enabled his QUAL system to recognize electrical circuits. That practical research along with NFIS, the theoretical "No Function in Structure" Principle (de Kleer and Brown, 1983), introduced and emphasized the utility of teleological biases in handling qualitative physics' explanation problem.

Although qualitative physicists have generally neglected teleology (due primarily to their focus on non-purposeful domains like the simple physics of bouncing balls and oscillating springs), as they attempt to move into complex domains, the need for teleological knowledge will certainly increase. Since QP already has general qualitative simulators, it seems only natural to aim toward enhancing them with general teleological models. Unfortunately, NFIS is too general and idealistic, while QUAL is too domain and task specific to provide the basis for such a general, yet operational, teleological model.

This dissertation investigates teleology in the domain of circulatory physiology and the task of criticism. Four important differences between this domain and task and those of QUAL should hasten the development of generic teleological models. First, electrical systems (and designed artifacts in general)

often have a small or singleton set of purposes, such as amplifying current or toasting bread; while physiological systems exhibit many diverse teleologies. Basically, function sharing is much more common in organisms than in artifacts. Second, the teleologies of artifacts are explicit and well-documented, whereas scientists constantly debate the salient purposes of physiological systems. Hence, an automated analyst of organic systems needs to critique from many different teleological contexts. Third, QUAL only considers teleological behavior in response to perturbations, while physiological systems exhibit purposefulness from both the dynamic and steady-state perspectives. Finally, the task of recognition often entails the disregard for envisionment interpretations that fail to satisfy the focal teleology (i.e., "negative instances" of the teleology), while criticism demands a careful evaluation and explanation of both positive and negative teleological activity.

As these four points indicate, the automation of physiological criticism via qualitative simulation and teleological knowledge should provide further background for the eventual development of general teleological models. Hence, the specific investigations of this dissertation should shed some light on the general explanation problem.

### The "What" and "Why" of Physiological Criticism

#### The Problem: Physiological Criticism

For the purposes of this dissertation, physiological criticism is a combination of the evaluation of a system's behavior relative to an environmental and teleological context, and the explanation of those behaviors in terms of the systems structure. For instance, in the reptilean circulatory system of Figure 1, notice that oxygenated pulmonary (i.e., pertaining to the lungs) blood mixes with deoxygenated systemic (i.e., pertaining to the body) blood in the ventricle. This delivers oxygen concentrations to both lungs and body that are suboptimal relative to the teleology of oxygen transport. The recognition and classification of these behavioral problems constitutes evaluation. These behaviors are then explained by the structural relationship between the lungs and body: they lie in parallel to one another along the circulatory loop, which causes the mixing, which creates the inefficient oxygen gradients.

Within an environmental context, physiological criticism again evaluates system behavior relative to a teleology; but this time, the behavior involves regulatory adaptations to the environmental conditions. For instance, we may assess the reptilean circulation's ability to transport oxygen while the organism swims underwater. In this case, the lungs become a very poor producer of oxygen, and the reptilean system adjusts by increasing pulmonary resistance to blood flow. Since the lungs and body lie in parallel, this resistance change shuttles most blood to the body and avoids the wasted effort of sending it to the lungs. Hence, in the underwater environment, the reptilean circulation does an optimal job, given the circumstances, of delivering oxygen to the body. Once again, the parallel relationship between

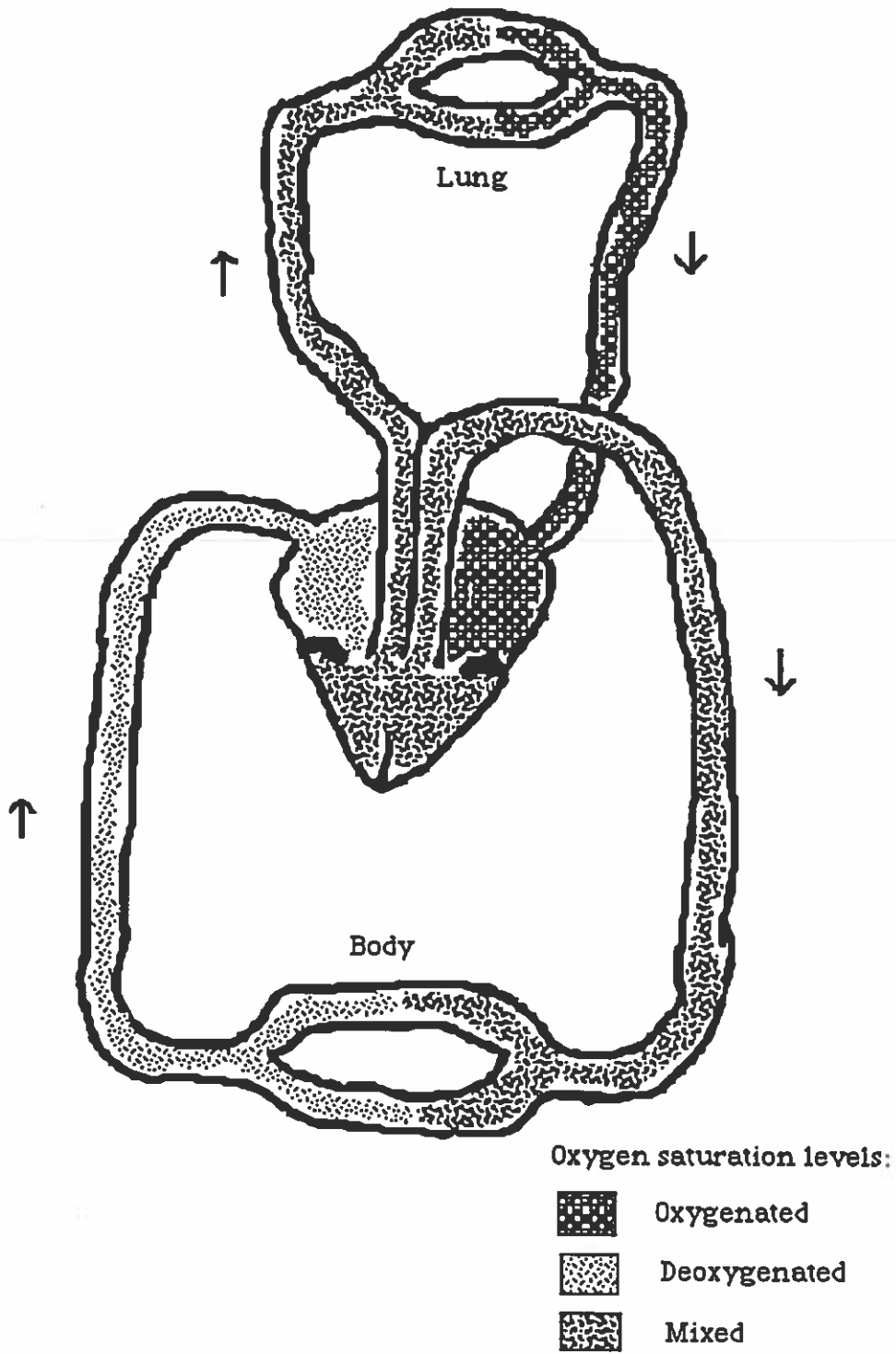

FIGURE 1. The reptilian circulation.

the pulmonary and systemic regions buttresses the explanation of the behavior.

### The Significance of Physiological Criticism

The problem of physiological criticism is interesting for a variety of reasons. For one thing, physiology lies at the heart of many taxonomic controversies over the form and semantics of the evolutionary tree. Physiological structures and behaviors often provide supporting evidence in the classification of various organisms; but even when a taxonomic tree is complete, physiologists still argue over the meaning of "dominance" in that evolutionary partial order. Some view mammals as the state of the art in evolutionary design. To these biologists, natural selection has been a lengthy optimization process culminating with humans. Hence, the semantics of the evolutionary tree involves not just a time order of emergence, but a sophistication ranking as well. Since mammals dominate, their anatomical and physiological structures may serve as "gold standards" for critiquing all extant and extinct organisms. Thus, reptiles, amphibians, fishes and birds all receive mediocre evaluations, since they just do not make very good mammals!

A more recent line of biological analysis cuts through the anthropocentric bias by examining organisms within the contexts of their environments. There, optimality entails the proper adaptation to a particular habitat, and not the similarity to some gold-standard organism who occupies an entirely different niche. Under this more context-sensitive and objective view of evolutionary prowess, many reptiles, amphibians, birds, fishes and insects receive marks equal to or above those of mammals. However, the objectivity of this adaptation-based criticism does not parlay into a concrete and objective formalism for systematic and automatable evaluation. By foregoing the mammalian gold standard, physiologists clear the way for new debates over the proper criteria for judging a physiological system's survival potential within a given environment. These disagreements often center around the choice of the most-relevant teleology - a critical issue in the formalization of any critiquing process.

A second major point of interest and controversy in physiological criticism is teleology. Reductionist biologists feel that their field reduces to physics and chemistry and therefore should not be biased by functional interpretations of the basic physicochemical phenomena. Furthermore, from the explanation standpoint, teleological views often serve as "intelligence loans" (Dennett, 1978) when full-fledged causal accounts are lacking. Still, the adamant disapproval of teleological approaches represents a fairly extremist view among biologists, most of whom recognize the importance of functional interpretations of primitive behaviors, especially in evolutionary biology and in general-biology education.

Beneath the arguments for and against teleological interpretation lies a related discussion over the relevant teleologies for biological analysis. Unlike man-made artifacts, which were presumably designed to fulfill a small set of explicit and well-formed purposes, living organisms have only implicit teleologies that are open to human interpretation and debate. And as the physiology literature indicates, the disagreements in evaluations of circulatory

systems, such as that of the reptile (Burggren, 1987), have little to do with discrepancies in empirical data but a great deal to do with differences in popular teleologies.

Thus, contemporary physiological criticism is a task without gold standards or design goals. Biologists may know the environment in which an organism lives and the macro-level tasks that it performs, but under the skin, bark or scales, the physiological functions that significantly contribute to survival are not always lucid. The only obvious fact is that the vital physiological teleologies vary with the organism and environment. Hence, criticism in the physiological domain requires a thorough consideration of a context composed of both an environment and a set of vital teleologies. For artificial intelligence, the task of physiological criticism thus presents an interesting challenge for automating the evaluation of physical systems and for investigating the role of environmental and teleological context in this critical analysis.

### Qualitative Physics meets Physiological Criticism

As mentioned above, the physiology literature is replete with circulatory criticisms that rely entirely upon qualitative and teleological constructs. For instance, Seymour (1987) discusses the pros and cons of an anterior heart (i.e., one that lies close to the head):

This evidence supports the hypothesis that elongation of the body of some terrestrial snakes has selected for anterior heart position and involvement of the carotid area in baroreception, both adaptations tending to stabilize cephalic blood pressure.

Despite the advantages in keeping the heart close to the head, there are hemodynamic disadvantages. One problem is that the pressure in the venous side of the circulation is also subject to effects of gravity and it may be difficult for blood in the venous system to return to an anteriorly placed heart in climbing snakes (Lillywhite, 1987). Venous pooling in the body below the heart reduces cardiac output and causes central arterial blood pressure to drop. This effect can have catastrophic results in some snakes, especially aquatic species with poor baroregulation in which venous return may drop to zero during tilting...

Another disadvantage is that the farther the heart is away from the body center, the more unequal are the amounts of blood pumped to the anterior and posterior parts of the body. This imbalance may result in a greater workload for the heart. (p. 103)

Seymour employs qualitative reasoning to describe both the effects of gravity on central arterial blood pressure and the relationship between the heart's position, the snake's environment, and the chosen physiological teleology. He evaluates the anterior heart in a variety of environments (arboreal, terrestrial and aquatic) and relative to three prominent teleologies: maintenance of adequate cephalic (head) blood pressure, avoidance of venous pooling, and minimization of heart workload.

Essentially, an anterior heart is helpful in maintaining adequate cephalic pressure, since the head and heart lie close to one another. This has particular advantages for arboreal snakes, whose frequent vertical orientation could otherwise cause low cephalic pressure, due to the difficulty of transporting blood against gravity. The cephalic pressure teleology is less of a concern for terrestrial snakes, who only occasionally contend with gravity; and it is trivially satisfied in aquatic snakes, who avoid gravity altogether. Hence, environment is a crucial consideration in the criticism of an anterior heart.

Furthermore, in gravitational environments, heart location represents a tradeoff between Seymour's three teleologies. Anterior hearts help maintain cephalic pressure but increase the heart's workload and the potential for venous pooling; mid-section hearts minimize workload and reduce venous pooling at the risk of cephalic pressure deficiencies. Hence, the teleology exercises an equally strong bias in the evaluation of serpentine heart location.

By using a purely qualitative description, Seymour conveys the essential relationships between a circulatory structure (the anterior heart), the possible environments, and the relevant hemodynamic teleologies. His concise and informative critique highlights the merits of qualitative explanations of physical systems. However, the presence of a qualitative explanation proves nothing about the qualitative or quantitative nature of the reasoning process used to formulate it. Seymour's explanation may be no more than the qualitative summary of quantitative measurements.

But in situations that demand qualitative explanations, the ideal reasoning process is also qualitative. This will elicit the connection between reasoning and conclusion while sparing us the effort of converting our qualitative knowledge into complete quantitative models and then qualitatively interpreting the results of quantitative processes. So at the very least, qualitative ends justify an investigation into the prospects of qualitative means.

Hence, physiological criticism constitutes an interesting task for qualitative physics; their integration promises mutual benefits for each endeavor. Qualitative physics can enhance automated physiological criticism along three lines: First, as discussed in greater detail below, qualitative simulation generates trees of possible system behaviors to more fully cover the behavior space. This lends considerable robustness to criticism by eliciting the full set of possible states that the system may enter. Second, qualitative simulators run on abstract (and often incomplete) models. Hence, one can encode and run a model directly from a basic physiology text, without requiring detailed quantitative knowledge of the system parameters (often found only in obscure lab reports). Finally, and most importantly, qualitative simulators often reason directly with the first principles of physical causality. This enhances the explanatory capabilities of simulation by greatly reducing the gap between the computation of system behaviors and the causal intuitions behind those behavioral interactions.

Qualitative physics (QP) also stands to gain from this interaction. While most QP work has focused on simple physical mechanisms or engineered artifacts, only a scattered few papers discuss biological applications. The first-principles of physics suffice to explain many biological phenomena such as blood flow, pulmonary ventilation, or oxygen diffusion; but in reducing a complex biological system to physical interactions, one frequently ignores

essential aspects such as teleology, fitness, environment, homeostasis, etc. Physics and chemistry capture the basic behaviors of biological systems, but only as context-free phenomena. As Ernst Mayr points out, biology differs from physics in the extreme time and space-boundedness of living things. Quoting partly from Max Delbruck (1949), Mayr(1988, p. 26) adds, "The animal or plant or micro-organism ... is but a link in an evolutionary chain of changing forms, none of which has any permanent validity.' There is hardly any structure or function in an organism that can be fully understood unless it is studied against this historical background." In short, every biological species constitutes a special case, one whose unique historical and environmental circumstances require careful consideration during the analysis and explanation of either the gestalt organism or its biological systems. Physics formalizes only the abstractions; and qualitative physics further abstracts over those. The extension of qualitative physics to physiology will therefore demand strict attention to the context of physical behavior.

In physiological criticism, the essential component of this context is teleology. Without it, we have no grounds for evaluation; for no physical behaviors are inherently helpful or harmful, good or bad. De Kleer and Brown have been the only qualitative physicists to explore teleological applications. In De Kleer's (1979) words:

The single fact that a device has a purpose often tells you a great deal. Every component in a circuit must have a purpose and therefore any analysis of the circuit that does not explain every component must be regarded with some suspicion. (p. 142)

By operationalizing this heuristic in his QUAL program, De Kleer convincingly illustrates teleology's utility in pruning envisionments during the automatic recognition of electronic circuit configurations.

In general, the work of de Kleer and Brown indicates that to qualitatively analyze and explain complex physical systems, qualitative physicists must supplement structural and behavioral knowledge with teleological information. The fact that most qualitative physics research neglects teleology represents less of an oversight and more of a domain dependence: most QP work involves simple systems such as springs, pendulums and heated water. In isolation, these systems have no real purpose; and to assume the contrary would set physics back many centuries. However, the ignorance of functional context has stymied the advance of qualitative physics into more complex domains, where the ambiguities of qualitative simulation promote a combinatorial explosion of possible behaviors. In the scaling up of qualitative physics to these difficult domains, teleology holds the key to both constraining envisionment and focusing explanation and criticism.

This dissertation focuses on the role of teleology in explanation and evaluation, rather than in the restriction of envisionment. As elaborated in the following chapter, *recognition* (as performed by de Kleer's QUAL) profits from teleological pruning of the envisionment, but robust criticism demands a thorough analysis of every possible system behavior. Whereas a recognition system scans a teleology space for one that matches a behavioral interpretation, a critic assumes a particular teleology and searches each interpretation for supports and violations of that purpose. Teleology governs

the explanations of all such behaviors, whether they satisfy the purpose or not. Because circulatory physiology is so rich in teleological interpretations, and because automated circulatory criticism requires the proper formalization and operationalization of these teleologies, I hope to exploit this domain and task to further expand the teleological contribution to qualitative physics.

In summary, this dissertation integrates qualitative physics and physiological criticism for their mutual benefit. Physiological criticism should gain from the robustness of qualitative simulation, the capability to simulate abstract models, and the ease of explanation. Conversely, qualitative physics should profit through the extension to a biological domain, through the relatively unexplored (from the QP perspective) task of criticism, and through the bipartite model of teleology indigenous to these biological systems and essential to our understanding of purposeful behavior.

### Teleology

By *teleology*, I mean the desired/intended global behavior of a system. In my research, a teleology embodies a goal, not a constraint, since a teleology may provide a framework for analyzing a system without necessarily being satisfied by that system. In fact, critical analyses of systems are often more enlightening when a system violates, rather than satisfies, a teleology. Constraints, on the other hand, generally demand ubiquitous satisfaction throughout all phases of system activity.

In BIOTIC, teleologies are goals at the level of circulatory physiology. They represent global behaviors such as oxygen transport: the transfer of oxygen from producer components, which allow oxygen to diffuse into the blood, to consumer components, which enable oxygen to diffuse out of the blood. This compiles into the subgoals of local production, local consumption, and producer-to-consumer blood flow. BIOTIC employs teleologies and their concomitant subgoals as the basis for evaluating, explaining, and (to a small degree) simulating circulatory systems.

De Kleer (1979) visualizes a teleological spectrum (see Figure 2) bounded at one end by physical phenomena such as a stone rolling down a hill. These events, when devoid of human intervention, seem to have no teleological interpretation. At the other end of the spectrum lie designed artifacts, which achieve their design goals through normal operation. De Kleer notes that in qualitative simulation, the disambiguation of behaviors requires different information for different points along the spectrum. For instance, the simulation of a physical phenomena can only be disambiguated by additional quantitative knowledge such as a new inter-parameter relationship or a tighter range on the value of a parameter. Alternatively, the envisionment of an engineered artifact can be pruned by teleological knowledge: any potential behavior that runs contrary to the design goals deserves no further consideration (when the task is recognition and when one assumes that the device works properly).



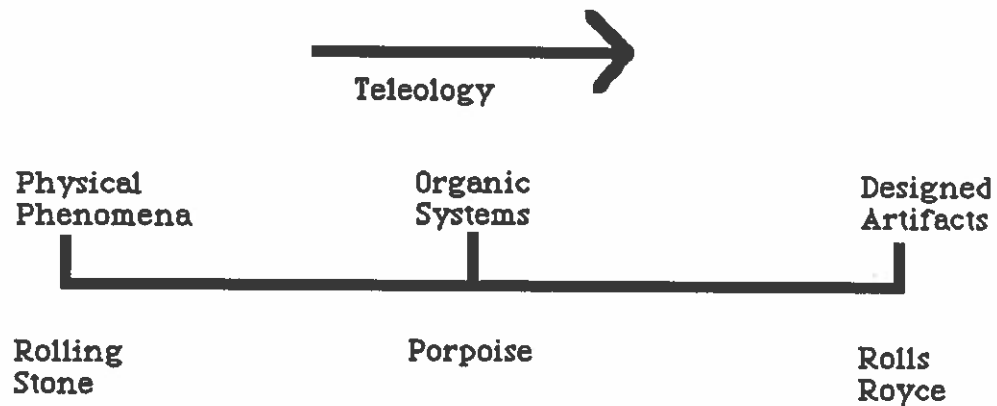

FIGURE 2. The teleological spectrum .

Organic systems fall somewhere in the middle of the teleological spectrum. We have no documented design specifications for a porpoise, for example, but we can interpret many of its behaviors relative to the goal of survival, which decomposes into subgoals of performing certain actions (e.g., swimming) in certain environments (e.g., cold water). At the physiological level, survival translates into a wide variety of advantageous behaviors such as conservation of heat, efficient delivery of oxygen, rapid removal of wastes, etc. These global physiological goals constitute teleologies in the BIOTIC system.

The circulation of a porpoise's flipper (see Figure 3) manifests the three survival subgoals mentioned above. Arteries deliver oxygen to the flipper muscles, veins return carbon-dioxide-laden blood to the lungs, and the close proximity of arteries and veins combines with their opposite but parallel flows to affect a counter-current heat exchanger in which heat from the arterial blood flows across the flipper to the veins. Hence, the arterial blood has little heat when it reaches the flipper's tip and therefore cannot lose much heat to the environment.

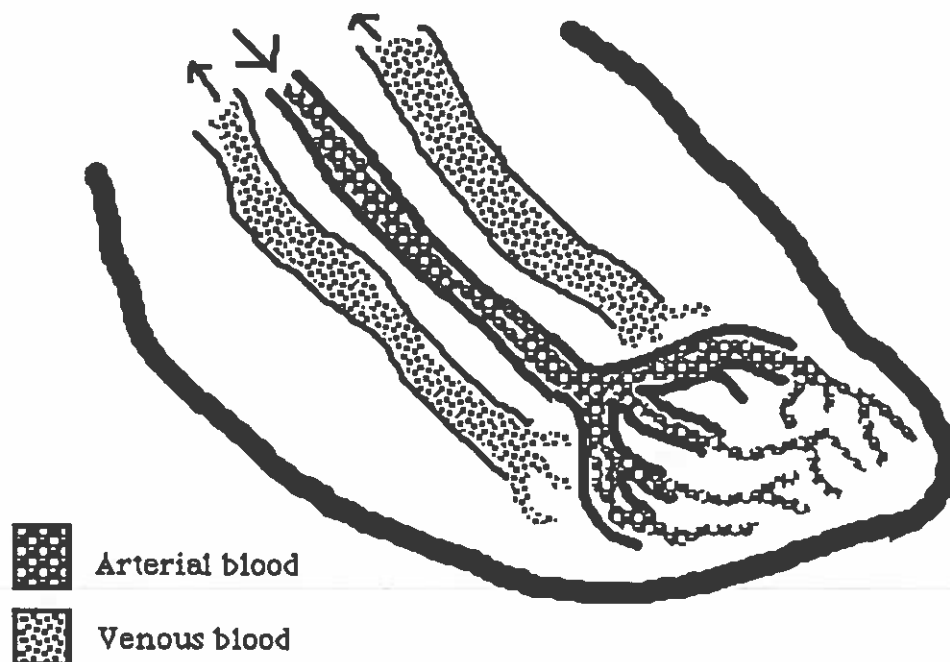

FIGURE 3. Circulation of the porpoise flipper.

Because the basic physical and chemical principles apply to physiological systems, we have the option of treating them as a collection of simple physicochemical phenomena and ignoring teleology altogether. A circulatory system would then have no more purpose than a rock slide. Qualitative simulations of such systems would require extensive quantitative information for disambiguation and their explanations would probably involve a complex network of causal relations. Alternatively, a teleological orientation provides a goal-directed framework for organizing and abstracting the causal events. For instance, from the functional perspective of oxygen transport, a circulatory system is a transport system linking oxygen producers (e.g., lungs) and consumers (e.g., muscles). This teleology has subgoals of sufficient blood flows, proper diffusion gradients and highly permeable membranes at the producers and consumers.

However, by taking a teleological approach to physiological analysis, we incur the difficulty of determining the relevant teleologies. For any physiological system, this set is both large and incomplete. Most systems, like the porpoise's flipper circulation, exhibit considerable function sharing: a few components realize many diverse purposes. Concerning the incompleteness problem, biologists are always finding new teleologies with which to reconcile "odd" designs. For instance, the countercurrent exchange concept was only discovered in 1944, and not until the late 1970's did biologists finally surmise a suitable functionality for reptilean circulatory systems, which were previously considered "primitive" in comparison to mammalian systems. Still, this multiplicity of teleologies makes physiology an excellent domain for an exploration of the teleological bias in structural criticism, because we can

alternately map different teleologies onto the same system and compare the evaluations.

### The Bipartite Teleological Model

Via circulatory criticism, BIOTIC makes its fundamental contribution to qualitative physics: the clarification of a bipartite teleological model and a formalization of its role in the analysis of complex systems. This has considerable relevance for any domain in which systems exhibit both steady-state and regulatory behavior, since both modes frequently succumb to teleological interpretation. For instance, from both perspectives an automobile satisfies the teleology of forward motion. During normal driving conditions, the wheels, axles, transmission, etc. facilitate movement (i.e., a steady state of constant forward motion). However, when skidding occurs, many newer-model cars automatically shift into four-wheel drive to help arrest the skid and maintain forward movement. In both cases, the automobile acts purposefully.

Qualitative physicists have not recognized these dual teleological modes, but philosophers have. Dennett (1978) contrasts the *design stance* with the *intentional stance* as two methods of teleologically predicting and interpreting device behavior. From the design perspective, one assumes that the device was built to achieve certain goals. The intentional stance elaborates the design perspective by assuming optimal design relative to a goal. This stance bestows rationality on the system by assuming that it will always manage to achieve its goal. For instance, in analyzing a chess-playing program from the design angle, we may assume that it was designed to play chess (i.e., it knows the rules) and will therefore make reasonable legal moves. An intentional view of the program would assume that it plays extremely well and therefore will make the optimal move in response to any of our actions. From the design perspective, the program acts purposefully; but from the intentional angle, the system's most prominent characteristic is its ability to react to a host of its opponent's moves in order to continue progressing toward its goal.

The difference between action and reaction also comes forth in the teleological theories of Rosenbluth, Wiener and Bigelow (1966). In their classic paper, "Behavior, Purpose and Teleology", they differentiate artifacts such as guns and clocks, which are designed for a purpose but whose behavior is not goal-directed, with *servomechanisms* such as temperature regulators and heat-seeking missiles, whose actual behaviors suggest an active awareness of their goals. In their view, purposeful behavior requires negative feedback, because the goal-directed mechanism must constantly monitor its environment and adjust its behavior accordingly (i.e., react). These systems exhibit *intrinsic* purposefulness, since they have an internal penchant toward goal attainment, while artifacts such as clocks exhibit only *extrinsic* purposefulness. The intrinsic mechanism seems to parallel Dennett's intentional stance in that both assume a strong commitment to a purpose via an ability to react to external perturbations. Similarly, the design stance mirrors the extrinsic mechanistic view in positing a weaker, non-dynamic dedication to the goal.

These philosophical theories hold relevance for qualitative physics, since both static and dynamic behaviors of qualitative models often have teleological interpretations. During static operation, the basic actions have

teleological import, while in more dynamic contexts, systems display purposefulness by reacting to perturbations. The most noteworthy exploration of teleology's role in qualitative physics is de Kleer's QUAL system (1979), which focuses on the dynamic aspects of electrical behavior in recognizing complex circuits. De Kleer (1979, p. 194) admits that QUAL cannot perform steady-state analysis but that an extension to the static perspective would open the way for teleological analyses of other systems such as logical circuits and mechanical devices. Since de Kleer seeks to model electrical engineers, who rely primarily upon perturbation analysis, the first-order perspective is of exclusive importance to QUAL. However, physiologists appear to use both perspectives in circulatory criticism; and, as the examples below illustrate, both vantage points highlight interesting connections between teleology, behavior and structure. Thus, physiological criticism provides an excellent arena for an investigation into bipartite teleology.

In this dissertation, I will synonymously refer to the static perspective as the "zero-order" perspective, while the dynamic view is also referred to as the "regulatory" or "first-order" perspective. These perspectives comprise the two halves of the bipartite teleological model, which forms the cornerstone of BIOTIC's critical analysis. From the static perspective, BIOTIC considers the physiological system during steady-state isolated behavior, while in the dynamic context, it assesses the system's ability to satisfy the teleology while regulating in response to external perturbations. Since homeostatic capabilities are the hallmark of living organisms, we can hardly provide accurate physiological criticisms without occasionally taking the regulatory perspective.

A physiological example should help clarify the distinction between the two teleological perspectives. Consider the human pulmonary (lung) and systemic (body) circulatory systems (see Figure 4), which have simultaneously evolved to statically and dynamically satisfy two (among others) crucial teleologies: (a) deliver oxygen to the metabolizing muscles and organs, and (b) maintain a relatively low pressure in the pulmonary capillaries.

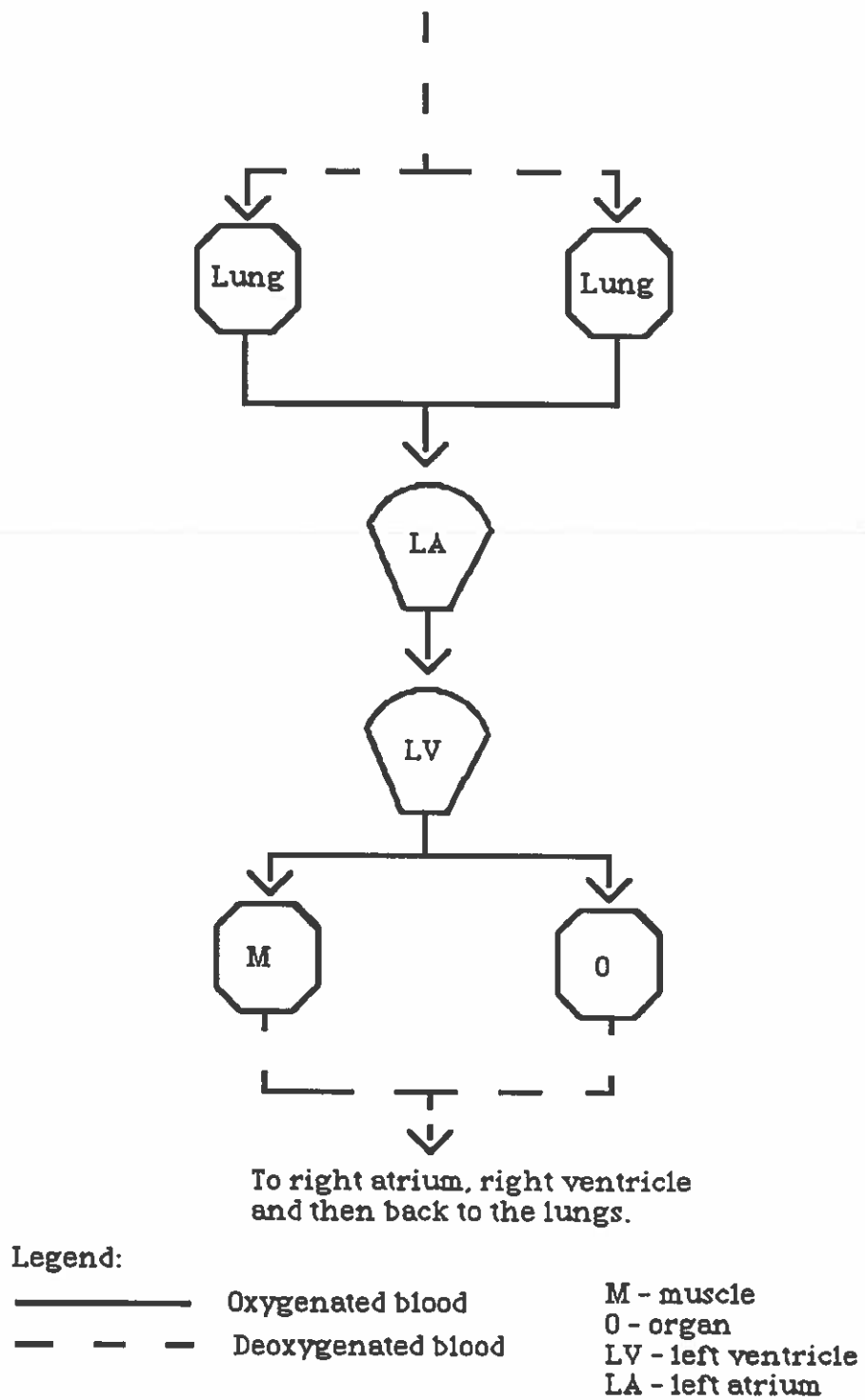

FIGURE 4. Human circulatory topology.

These goals have both static and dynamic perspectives. Via their fixed location within the circulatory system, lungs maximize their ability to deliver

oxygen while minimizing their capillary pressures. To wit, lungs lie in series with muscles and organs to insure that all blood deoxygenated by these metabolizers is re-oxygenated before cycling back for another delivery. Also, a good deal of resistant vasculature separates the high-pressure-producing left ventricle from the pulmonary capillaries. As a result, blood pressure diminishes by an order of magnitude between the left ventricle and the lungs, thus satisfying the second goal. So, under normal/static conditions, the topological relationships between the human hearts, lungs and muscles helps insure the satisfaction of both teleologies.

Dynamically, the lungs react to perturbations to insure the continued satisfaction of these goals. When an alveolar section becomes oxygen deficient (when, for example, its air-supplying bronchial tube gets blocked), the capillaries that those alveoli normally service automatically constrict. This re-routes blood to the properly-oxygenated alveoli, which lie in parallel to the constricted ones. Furthermore, during heart failure, abnormally high pressure builds up in the left atrium, which lies immediately downstream from the pulmonary circulation. In response, the body methodically opens more pulmonary capillaries. This decreases pulmonary resistance and prevents the high pressure from migrating upstream into the lungs.

The lungs and muscles were integrated into the circulatory topology in accordance with various survival goals; but the basic structural topology cannot anticipate the host of potential behavioral disturbances. Regulatory mechanisms pick up the slack by providing dynamic support for the survival goals. Together, the static and dynamic mechanisms operate to insure the continued survival of the organism. To evaluate and explain circulatory behavior, BIOTIC must understand both of these perspectives.

### The Bipartite Teleological Model in Circulatory Criticism

To this point, we have seen that physiological systems satisfy a variety of purposes from both a static and dynamic perspective. These multiple teleologies and perspectives, in combination with the wealth of external environments, provide many diverse contexts for physiological criticism. In the physiological literature, no circulatory critiques better illustrates this diversity than those of the reptile.

For years, physiologists considered the reptilean circulatory system primitive in comparison to that of the human (which seems rather absurd, since reptiles have inhabited the earth for many more years and have physiologically evolved to fill considerably more niches than humans!). The bias behind this anthropocentric view was one of teleological rigidity. Scientists criticized the reptilean circulation relative to a single teleology and perspective: zero-order oxygen transport, which just happens to be a standard that the mammalian circulatory system satisfies par excellence. However, recent studies (Burggren, 1987) show that when viewed from other teleologies and perspectives, the reptilean circulation far outshines the mammalian. As recounted below, Burggren's study colorfully exemplifies the sizeable contribution of multiple teleologies and perspectives to the robustness of circulatory criticism.

The reptilean circulatory system delivers blood to two primary regions: the body or systemic region, and the lungs or pulmonary region. These two regions lie in parallel to one another (see Figure 1), which contrasts with the topologies of mammals and birds, where those areas are in series. From the teleological perspective of zero-order oxygen transport (i.e., delivering oxygen to the body under conditions of normal metabolic, cardiac and respiratory activity), the glaring deficiency of a parallel arrangement is the mixing of oxygenated and deoxygenated blood that occurs in the ventricle. As shown in the figures, this mixing leads to the delivery of poorly oxygenated blood to the muscles and poorly deoxygenated blood to the lungs. To maximize the lung-to-body oxygen transfer during a cycle of blood flow, the muscles should receive highly oxygenated blood, and the lungs should get a low-oxygen flow. This enables the highest rates of oxygen diffusion to occur at both source and sink and is precisely what happens in the serial mammalian topology.

Another zero-order problem with the reptilean circulation is that when two regions lie in parallel, they are apt to receive similar pressures from the heart, modulated by the differences in resistance of the two regions. In larger terrestrial and arboreal animals, the delivery of blood to the extremities requires a high driving pressure to combat gravity. If a similar pressure were transmitted to the lungs, they would develop edema (i.e., flood with water that is forced out of the plasma by the high pressure), which often has fatal consequences. So, from the zero-order, pulmonary-pressure-maintenance teleology, the reptilean circulation also ranks far below the mammalian circulation, in which a separate, weaker ventricle (the right ventricle) pumps into the pulmonary region.

These criticisms, particularly the first one, have assisted scientists in neatly fitting the reptile into a ladder of evolutionary sophistication at a point midway between amphibians and homeotherms (i.e., warm-blooded animals). However, this nearsighted view fails to recognize the environmental differences between reptiles and homeotherms. An analysis of the reptile's regulatory responses to these environmental factors attests to the reptilean circulatory efficiency from a first-order teleological perspective.

For instance, many reptiles such as turtles, snakes and crocodiles spend a good deal of time in the water - often submerged for long periods of time. During diving, the lungs are not ventilated with oxygen. From the oxygen-transport perspective, it therefore make little sense to perfuse them with blood. The beauty of the parallel pulmonary and systemic circulation is that blood distributions between the two regions can change according to their comparative resistances. During diving, the resistance rises in the reptile's pulmonary region, thus "shunting" more blood into the systemic portion. After diving, when the animal needs to quickly rid it's system of carbon dioxide, blood shunts the other direction: the majority goes to the lungs. Mammals, with their dual-ventricle hearts, cannot perform this dynamic redistribution; since their two regions are in series, each receives essentially the same blood flow under all conditions. Thus, reptiles but not homeotherms achieve an optimal ventilation-perfusion match during apnea (non-breathing periods).

From the thermal-regulation perspective, the reptilean circulation also exhibits incredible sophistication. Unlike endotherms, which produce most of their heat internally, reptiles are ectotherms and thus rely on the environment for heating and cooling. However, studies show (Turner, 1987) that when reptiles are exposed to sudden changes in ambient temperature, they

warm up faster than they cool down . This indicates that physiological processes are at work to partially regulate internal temperature. To use the ambient temperature to their advantage, reptiles regulate blood flow to the different temperate regions of the body. For instance, while warming in the sun, lizards increase blood flow to the skin to absorb greater amounts of heat. When attempting to keep cool in a warm environment, they distribute more blood to the lungs, which dissipate heat during expiration. So once again, the parallel organization of pulmonary and systemic regions enables the reptile to maintain its commitment to an essential teleology in the face of a dynamic environment.

Burggren's research clearly illustrates the importance of multiple teleologies and perspectives in the criticism of circulatory systems. From the zero-order perspective, the reptilean circulation seems lacking under a variety of teleologies; but from a broader view encompassing the animals environment and physical activity, the reptile displays first-order teleological prominence. Burggren expounds on this in his summarizing remarks:

Extant reptiles exhibit great interspecific variability in both cardiovascular structure and function. There are frequent and major departures from the common (but incorrect!) view of the evolution of the vertebrate circulation that places a primitive and inefficient reptilean heart on a direct and ascending continuum between that of extant amphibians and homeotherms. This erroneous view, historically rooted in the supposed superiority of the completely divided avian and mammalian circulation, implies that intracardiac shunts in the reptilian heart are the unfortunate consequence of an undivided circulation unable to separate oxygenated and deoxygenated blood entering the heart. In fact, the redistribution of cardiac output between systemic and pulmonary circulation via central vascular shunting is a carefully regulated physiological process, and allows for effective matching of lung perfusion to lung ventilation during intermittent breathing. (p. 18)

In conclusion, Burggren's work stirs up many interesting points. First, criticism is directly governed by teleology; different teleologies can inspire vastly different critiques. Second, physiology admits many equally-important teleologies. Scientists never fully agree on their comparative relevances, so organisms such as the reptile frequently get mixed reviews. Third, the robust analysis of a physiological system requires viewing from both the static and dynamic/regulatory perspectives, regardless of the teleology. In other words, along with normal steady-state behaviors, environmental factors and a system's ability to adjust to them are important factors for structural criticism. Fourth, notice that although we take both a static and dynamic view of behavior, our final criticisms address the same thing: the circulatory topology, or, in this case, the parallel arrangement of lungs and muscles. This overlap is crucial for robustness. Finally, the presence in the physiological literature of criticisms based on both static and dynamic purposefulness clearly indicates the importance of both computationally formalizing a bipartite teleological model and investigating its role in physiological criticism.



### Summary, Thesis Statement and Research Issues

This dissertation focuses on the qualitative and teleological aspects of physiological criticism. As illustrated by the previous examples, physiological explanation and evaluation involve a good deal of qualitative reasoning and demand a careful attention to teleological context. The former trait encourages the application of qualitative physics to the physiological criticism problem, but the latter characteristic renders this technology transfer quite difficult, because qualitative physics lacks a general model of teleology. Hence, physiological criticism poses an interesting task and domain for formalizing the teleological notions that appear so vital to the up-scaling of qualitative physics.

A study of the philosophical and physiological literature reveals two levels of teleological activity: goal-directed behavior in isolation, and functional commitment in the face of environmental perturbation. I view the formalization of this distinction as a crucial first step in the creation of a general teleological theory for qualitative physics. By codifying this bipartite teleological model and applying it to circulatory criticism, I will investigate the following thesis statement:

The integration of qualitative simulation with a bipartite model of teleology suffices to automate the process of circulatory criticism.

Furthermore, this dissertation address three general research issues. First, how does (and how will) teleology assist in the extension of qualitative physics to complex domains? De Kleer (1979) has documented the virtues of both local and global teleologies in pruning the search space of a qualitative simulation during the recognition of complicated electronic circuits. His work implies that teleology provides one of the fundamental tools for scaling up qualitative physics to complex domains. This research seeks further verification of that hypothesis in a domain where teleologies are equally prevalent but less explicit, less formal, and much more controversial.

Second, how does the teleological bias in qualitative physics vary with the task? For the task of recognition, de Kleer (1979) works under the assumption that the artifact was *properly* designed to achieve some purpose. This enables him to prune all envisionment interpretations that fail to satisfy the purpose(s). In contrast, a critic runs under the assumption that the system was probably *improperly* designed. Hence, interpretations that do not meet the teleology are not simply rejected, but analyzed, explained and possibly used as the basis for structural modifications. In physiological criticism, especially within the field of comparative physiology, it is often enlightening to see why different systems fail to satisfy certain teleologies in particular environments. This helps illustrate the fine-tuning of the evolutionary process. In short, automated critics generally take equal interest in success and failure; they therefore cannot exploit teleology in the same way that recognition systems do. Furthermore, tasks like simulation and diagnosis use teleology in other different ways.

Finally, can a qualitative biology be built from the fundamentals of qualitative physics? Although reductionist biologists might contend that qualitative physics in combination with a qualitative chemistry would suffice for biology, physicochemistry deals at a much higher level of abstraction than biology. As discussed by Mayr, the space and time-boundedness of biological systems demands a deeper look into the historical, environmental and teleological context of life. Qualitative biology must therefore formalize this context in order to adequately convey the essential intuitions behind biological reasoning. This dissertation looks at the teleological and environmental aspects of this context and shows how they integrate with the qualitative physics of blood flow and diffusion.

### Overview

Chapter II gives a brief overview of qualitative physics, its basic concepts, pros and cons. It also summarizes previous research that directly or indirectly relates to this dissertation. Chapter III introduces the producer-consumer model and the qualitative elements of circulatory physiology that are important to BIOTIC. The chapter concludes with an introduction of The Bipartite Teleology Model (BTM), which formalizes bipartite teleology for producer-consumer networks. The next two chapters illustrate BTM's operationalization in BIOTIC. Chapter IV presents some of BIOTIC's basic algorithms, and Chapter V describes their application to a few common circulatory models from a variety of critical angles. In Chapter VI, I informally evaluate BIOTIC by comparing its critiques to those of a published report by a well-known circulatory physiologist, and by comparing its general methods and critiques to those of two local physiologists. Finally, in the conclusion, Chapter VII, I (a) discuss BIOTIC's contributions to qualitative physics, (b) attempt to answer the three research questions posed earlier, and (c) speculate on future work.

## CHAPTER II

### QUALITATIVE PHYSICS FUNDAMENTALS AND RELATED WORK

This thesis attempts to advance the field of qualitative physics through the formalization of teleological models in physiological criticism. As background, it is important to review the seminal work in qualitative physics.

To date, very little has been done with teleological reasoning in qualitative physics, primarily because most QP work has focused on simple systems that, in isolation, lack even an inkling of purposeful behavior. For instance a spring, the favorite example of qualitative physicists, may fulfill many functions in a variety of artifacts; but as an independent system, it has no purpose. Only in scaling up qualitative physics to complex designed (either by humans or by evolution) systems do we recognize the vital role of teleology in helping us to understand the vast array of causal interactions within these systems.

This chapter begins with an introduction to the basic terminology of qualitative physics. It then presents the three representational paradigms that have governed the first decade of QP research: qualitative differential equations, qualitative process theory, and confluences. Finally, the introduction of teleology to qualitative physics, as pioneered by de Kleer and Brown, is described and contrasted with the aims of this thesis.

#### The Fundamentals of Qualitative Physics

Qualitative physics is the study of the representation, simulation, diagnosis and explanation of physical systems through symbolic, non-numeric techniques. Qualitative physics research has focused primarily upon qualitative simulation. Qualitative system models (or structures) are simulated to yield trees of potential behaviors. In QP terminology, each possible behavior is an *interpretation*, while the complete tree of interpretations is an *envisionment*. The ambiguities of qualitative arithmetic often enable a single structural description to predict many interpretations (i.e., the envisionments are very bushy). This multiplicity of predictions has the advantage of indicating all or most of the potential behaviors of a system without requiring an exhaustive set of quantitative simulations. However, envisioners frequently cannot determine which of the interpretations is most likely to mirror the real-world situation. Hence, qualitative physics trades off accuracy for completeness - making its merits very task specific.

For instance, a doctor may not trust a qualitative model to test the effects of a specific drug and dosage on a specific type of patient but may find it useful in circumscribing the range of patient responses to a particular category of

similar drugs. For instance, Campbell (1979) discusses the range of qualitative cardiovascular reactions to inotropic agents:

In cardiogenic shock, stroke volume and thus cardiac output is significantly depressed while arterial pressure is maintained close to, but most often below, normal values. Treatment for such a patient, seeks safely to return cardiac output levels to normal. The obvious route to accomplish this goal is through the administration of positive cardiac inotropic agents, such as digitalis or catecholamines. These drugs will affect the heart in such a way as to . . . make stroke volume less sensitive to cardiac pressure . . . and thus define a new equilibrium point that is closer to normal operating levels.

However, the administration of inotropic agents is not without attendant dangers. These agents increase myocardial excitability, increase cardiac work loads, and increase myocardial demands for oxygen and nutrients. All of these effects can be deleterious or even fatal . . . Therefore, inotropic agents should be given with caution. (p. 20)

Given a model of the appropriate qualitative relationships between parameters such as cardiac pressure, cardiac output, and myocardial workloads and oxygen demands, a qualitative simulator could easily envision both the virtues and dangers of inotropic-agent therapy.

Diagnosis can also profit from qualitative methods, since a diagnostician frequently encounters odd behaviors, many of which reside along possible but unexpected paths of the envisionment. Consider Guyton's (1986) description of the effects of efferent arteriolar constriction upon glomerular filtration rate in the kidneys:

Constriction of the efferent arteriole increases the resistance to outflow from the glomeruli. This obviously increases the glomerular pressure and at small increases in efferent resistance often causes a slight increase in glomerular filtration rate. . . . *However*, the blood flow decreases at the same time, and if the degree of efferent arteriolar constriction is moderate or severe, the plasma will remain for a long period of time in the glomerulus, and extra large portions of plasma will filter out. This will increase the plasma colloid osmotic pressure to excessive levels, which will cause a paradoxical decrease in the glomerular filtration rate despite the elevated glomerular pressure. (pp. 399 - 400)

Basically, when blood comes into the glomerulus, much of the plasma tends to get pushed into the Bowman's capsule by osmotic and hydrostatic forces. This is called glomerular filtration. The remaining plasma then exits the glomerulus via the efferent arteriole. As Guyton notes, the intuitive result of increasing efferent resistance is that less plasma will leave the glomerulus and therefore more filtration will occur. However, when the incoming glomerular flow decreases, the easily-overlooked consequence of excessive filtration is the "paradoxical" decrease in overall filtration rate; or from a diagnostic perspective, a non-intuitive cause of decreased glomerular filtration

is efferent arteriole constriction. Given the proper qualitative relations between efferent resistance, glomerular flow, glomerular pressure, plasma colloid osmotic pressure, and glomerular filtration rate, an envisioner would derive all the possible consequences of increased efferent resistance, including the paradoxical ones. These consequences could then be used by the diagnostician as possible symptoms of increased efferent resistance.

Structural criticism also seems ripe for qualitative analysis, since the completeness of envisionment along with its tolerance for imprecise inputs should enable a critic to both condense a wide range of quantitative situations into equivalence classes of qualitative ones and to view the breadth of possible outcomes. In looking back at Seymour's evaluation of the anterior heart (see previous chapter), first notice that "anterior heart" covers a large class of quantitative heart-head distances. Also note that the initial assessment is good: an anterior hearts help stabilize cephalic pressure. However, a more thorough analysis reveals possible problems: increases in venous pooling and heart workload. Again, assuming the proper model, an envisioner could derive all of these potential consequences. Also, the primitives of automated qualitative interaction often mimic our intuitive causal notions and thereby enhance explainability, as evidenced by Seymour's descriptions. In short, qualitative techniques should improve the robustness of evaluation and the effectiveness of explanation.

### Structure, Behavior and Function

Qualitative physics revolves around three fundamental concepts: structure, behavior and function. Structure embodies the statics of a situation: the objects, their properties and relationships. The time-varying states of those objects comprise the behavior; while the purpose or teleology of a system or device defines its function. Consider a bicycle, whose structural description includes its wheels, brakes, frame, chain, pedals, and their static interconnections (ie. the chain connects the back wheel and the pedals). Its behaviors include the rotating of the wheel, the slight bending of the frame, and the forward movement of the entire bicycle. As in any designed artifact, the functions are abundant: spokes serve to support the wheel, handlebars aid in steering, the brakes function to arrest motion; the bicycle's global teleologies include transportation and recreation.

To date, most qualitative physics research has considered only the first two concepts: structure and behavior. Qualitative simulation (the primary task of previous QP research) requires no teleology. Seminal QP work differs primarily in the ontologies of structural representations. De Kleer and Brown (1985) and Williams (1985) use components (e.g., resistors, capacitors, valves) described by qualitative partial-differential equations as structural primitives. Forbus (1985) describes the physical world in terms of processes, which he represents as STRIPS-like (Fikes, 1971) rules with pre- and post-conditions that are elaborated to handle the continuities of physical change. Kuipers (1985) sticks closest to mathematics by employing qualitative differential equations and making no commitments to the local or global nature of the constraints. To him, a system's structure is simply its state variables and their constrained relationships.

### Three Representational Paradigms of Qualitative Physics

Together, De Kleer, Brown, Forbus and Kuipers have defined the field of qualitative physics. All have made significant progress in formalizing structure, behavior and their relationships via qualitative simulation (i.e., envisionment). Below, I will review each of their contributions before discussing De Kleer and Brown's introduction of teleological reasoning into qualitative physics.

#### Kuipers' Constraint-based Paradigm

Kuipers (1986) has been instrumental in clarifying the relationship between mathematics and qualitative simulation. Using the quantitative differential equations describing a system as a "gold standard", he proves that the qualitative abstractions of those equations lead to simulations which are complete but unsound. In other words, the interpretations stemming from envisionment are a superset of the possible behaviors of the actual system (as described by ordinary differential equations). Hence, qualitative simulation admits "spurious" behaviors. Most of Kuipers recent work involves diverse attempts to restrict the spurious behaviors generated by QSIM (Kuipers, 1985), his well-known qualitative simulator. In (Kuipers and Chiu, 1987), he abstracts over unimportant behaviors, while in (Kuipers, 1987) he abstracts over time; both methods cut down on spurious predictions. In (Lee and Kuipers, 1988), he exploits qualitative phase spaces for envisionment pruning. Finally, in both (Kuipers and Chiu, 1987) and (Kuipers and Berleant, 1988) he prescribes the quantitative remedies of higher-order derivatives and value ranges, respectively. Basically, Kuipers has tried everything but teleology to combat the unsoundness problem.

Among qualitative physicists, Kuipers has made the only noteworthy advances into the physiology arena by running QSIM on various cardiovascular and renal (i.e., pertaining to the kidney) examples. In (Kuipers and Kassirer, 1984), they convert a doctor's qualitative reasoning into a QSIM model of the effects of protein loss on water retention. While in (Kuipers, 1987), he models the related mechanisms of water and salt regulation in the blood. Finally, in (Kuipers, 1987 IEEE), he considers the diagnosis of those same regulatory mechanisms from a first-principle perspective. There, he differentiates medical from electrical domains by contrasting the component-centered electrical models with physiological systems governed by regulatory mechanisms. Consequently, he models physiological "faults" as altered homeostatic mechanisms. For instance, he uses a relaxed constraint relationship between plasma sodium and plasma antidiuretic hormone (ADH) to represent the SIADH syndrome, a condition in which the blood level of ADH soars and thereby interferes with the normal regulation of sodium and water in the blood.

Kuipers' advocacy of regulatory-centered views of physiological systems supports a primary tenet of this thesis: a fundamental basis for the

criticism of circulatory systems is their ability to adjust to environmental perturbations. However, QSIM alone cannot perform circulatory criticism at the topological level, since its conception of "structure" is nothing more than a qualitative equation. It fails to capture the relationships between those equations and the actual physical structure. So, in the case where a lung lies directly downstream from a ventricle, QSIM might explain pulmonary edema (i.e., buildup of water in the lungs) in terms of excessive pulmonary blood pressure but could not relate that to the chief structural flaw: the proximity of heart and lung. Still, Kuipers has pioneered the advance of qualitative physics into the complex domain of physiology. His successes lend confidence to follow-up investigations, while the limitations of the QSIM paradigm leave many inviting areas of future research.

### Forbus' Qualitative Process Theory

Forbus has made a major impact with Qualitative Process Theory (1985), which can model everything from fluid flows to springs to naive physics concepts such as Aristotelian motion - all in terms of processes. QP Theory provides an exceptionally thorough model of causality, which receives further clarification when contrasted with related causal models in (Forbus and Gentner, 1986a). Furthermore, QP theory has provided the foundation for a theory of human learning (Forbus and Gentner, 1986b), a model of planning in physical domains (Forbus, 1988a), a qualitative data interpretation scheme (Forbus, 1983; Forbus, 1986a; DeCoste, 1989), and an operational model of "piece of stuff" reasoning (Collins and Forbus, 1987). More than any other qualitative physics paradigm, QP Theory exhibits sensational generality across a plethora of diverse domains and tasks.

The Qualitative Process Engine (QPE) (Forbus, 1986b) is the contemporary implementation of QP Theory. QPE improves on previous QP Theory implementations via the use of an assumption-based truth-maintenance system (ATMS) (de Kleer, 1986) to efficiently manage the assumptions of qualitative reasoning. As mentioned earlier, the ambiguity of qualitative arithmetic leads to branches in the envisionment. Rather than trying to prune those branches, Forbus focuses on speeding up the envisioner by fine-tuning its context-switching mechanism - thus enabling QPE to quickly create and move around in the behavior tree. This reflects a fundamental ideological gap between Forbus and researchers such as Kuipers (Kuipers and Chiu, 1987), Struss (1988) and Toale (1988) who seek to relieve the unsoundness of envisionment via tree pruning. Forbus(1986b) hails the virtues of bushy envisionments, most importantly, their complete coverage of the behavior space. On this he remarks:

Exploring only one alternative may suffice for some tasks, particularly when other sources of information are available to rule out other alternatives. But often this limitation is unacceptable. For example, in designing complex physical systems exploring all behaviors can reveal all failure modes. A subset of behavior the designer did not choose to explore (or that was pruned

from consideration by some heuristic) could hide a potential catastrophe. (p. 1)

He goes even further by discounting Kuipers' (1986) "unsoundness" verdict as a problem indigenous only to qualitative simulators that dynamically generate landmark values (e.g., QSIM). Hence, Forbus sees complete, unrestricted envisionments as essential tools for the robust exploration of complex domains.

Following Forbus's penchant for efficiently managing the assumptions underlying envisioning's ambiguity, he and Falkenhainer (1988) scale up QPE to model a steam plant. They combine explicit granularity and behavioral assumptions to build highly flexible domain models whose behavioral biases (during envisionment) change in accordance with the active modeling assumptions. For instance, via simple *consider* assumptions, they can command the simulator to ignore the thermal properties of some or all of the steam plant's liquids. Conversely, in focusing on the thermodynamics of steam generation, they can ignore many hydraulic properties of the liquids and can also shift to a higher level of structural granularity by ignoring many pipes and valves.

In addition, they propose an explanation-generation technique in which the student's query indexes into a set of modeling assumptions, which then bias envisionment so as to only generate behaviors that relate to the requested information. They do not give examples of this query-answering process, but they do sketch an abstract algorithm showing the relationships between queries and consider assumptions within the framework of the ATMS. Overall, their theory seems quite powerful and robust; and initial prototypes show a considerable speedup over full, unbiased envisionments.

Most recently, Skorstad and Forbus (1989) have combined qualitative and quantitative reasoning to solve complex, quantitative textbook thermodynamics problems. In general, these problems involve a qualitative model of steam plant and a quantitative query, which provides the quantitative values of assorted steam-plant parameters and requests the quantitative value of another variable. Their system, SCHISM, uses envisionment and qualitative heuristics to properly aggregate a thermodynamic system into control volumes - the primary abstraction for thermodynamic problem solving. The envisioning and aggregating results then dictates the appropriate quantitative equations for solving the initial query. In essence, Skorstad and Forbus use qualitative knowledge to perform the hard part of engineering problem solving: selecting and organizing the appropriate quantitative equations. In addition, they exploit limited teleological knowledge to prune their envisionments. This seems to contradict Forbus's insistence on complete envisionments, but the task seems to justify teleological pruning. To wit, when a thermodynamics question states that the relevant device is a heat engine (which demands behaviors such as a transfer of heat and an output of work), and, in the context of textbook problem solving, we normally assume the normal unfaulted behavior of that device. Hence, solving the problem requires an exclusion of all behavioral interpretations that fail to exhibit heat-engine characteristics. In summary, SCHISM is generally significant for its integration of qualitative and quantitative techniques; but concerning this thesis, the implicit message is two-fold: (1) the debate over complete versus pruned envisionments is a task-



sensitive issue, and (2) teleological information can enhance the pruning process.

In review, Forbus has done a lion's share of the seminal qualitative physics work by applying QP Theory to a great many tasks and domains. However, he has yet to tackle structural criticism - possibly due to its stereotypically component-oriented nature. Through most of his work, a ubiquitous moral repeatedly surfaces: the power of qualitative simulation lies in its complete coverage of the behavior space. Attempts to restrict that coverage should proceed only with the explicit awareness and formal management of the biasing assumptions (i.e., those that prune the envisionment or abstract the original model). This caveat carries obvious implications for structural criticism: since a critic searches for flaws in a system, it needs to consider a good many of its potential behaviors. Robust criticism and complete envisionment therefore go hand in hand.

### De Kleer and Brown's Confluence Theory

Having considered the constraint-centered and process-oriented approaches, we now move to the component-based ontology and its most famous manifestation: de Kleer and Brown's confluence theory (1985). Highly tuned for domains such as electronics, hydraulics, mechanics and thermodynamics, confluence theory models systems as collections of components, each described by a set of local, qualitative, partial-differential equations or *confluences*. Envisionment alternates between an intrastate phase, in which perturbations are propagated through the confluences to determine the qualitative derivatives of state variables, and an interstate phase, wherein derivative information is used to determine which state variables will transition across significant landmark points - thus altering the behavioral topology of the system. For instance, when the cross-sectional area of a valve goes to zero, so does the flow across it, and the relationship between pressure and flow vanishes. Hence, the new operating region has a new set of confluences, which lacks, among other things, a constraint between the valve's pressure and flow. De Kleer and Brown equate their intrastate constraint propagations with causal explanations across "mythical time", while interstate changes happen in real time.

Confluence theory clearly highlights the two primary sources of envisionment's ambiguity: intrastate and interstate reasoning. In the former, constraint propagation across confluences encounters one of at least three problems:

1. A confluence with  $n$  qualitative derivatives has less than  $n-1$  of them instantiated and thus cannot solve for the remaining derivatives via simple local arithmetic reasoning.
2. Two instantiated qualitative derivatives of a confluence combine arithmetically to produce an ambiguous result; eg., the sign of a positive number subtracted from another positive number is undefined.

3. Two different propagation paths justify conflicting values for the same qualitative derivative.

De Kleer and Brown introduce the *component*, *conduit* and *confluence* heuristics to bias constraint propagation (and thereby alleviate intrastate ambiguity) according to standard causal reasoning techniques gleaned from electrical engineers.

The ambiguity of interstate reasoning stems from incomplete knowledge about which state variable will hit its landmark value first. De Kleer and Brown combat this with assorted limit-analysis rules. By cleanly separating intrastate and interstate reasoning, they clearly expose the dual rudiments of envisioning ambiguity and the different techniques for (partially) resolving it.

### Ambiguity: The Common Bond

As evidenced above, a primary concern that transcends the ontological gaps between the constraint, process and component-centered modeling perspectives is ambiguity, the pro and con of qualitative reasoning. In trying to simulate over only the important abstractions of a situation, we have disposed of a great deal of pivotal information.

How much of it must we retrieve? How much of it can we rightly accept and still call our models "qualitative"? How about "robust"? These and other issues haunt the region of supplemental knowledge that separates pure qualitative from pure quantitative models. The introduction of teleology into qualitative reasoning helps resolve many ambiguity problems.

### Teleology in Qualitative Physics

Teleology represents a prime source of supplemental knowledge for reducing ambiguity. We use it frequently during our own qualitative physical reasoning. Imagine you are watching a baseball game in a domed stadium, and a pop-up is sent soaring toward the ceiling. If you relied solely on structural and behavioral knowledge, the limit analysis needed to determine whether or not the ball would hit the roof would probably require additional quantitative knowledge such as the ball's velocity, the acceleration of gravity and the height of the dome. But the average baseball fan lacks this data and instead employs basic functional information: since the dome was *designed* not to perturb the flight of baseballs, the pop-up will not hit it. Tacit teleological knowledge thus reduces the ambiguity of qualitative reasoning.

De Kleer and Brown (1983) recognize the power of teleological biases in modeling, simulating and troubleshooting designed artifacts. However, via their "No Function in Structure" (NFIS) principle, they warn that functional assumptions, if embedded in a component's local behavioral model, can greatly undermine the robustness of simulation. Still, they acknowledge the indispensability of teleology in the interpretation and explanation of envisionments. The ramifications of NFIS are twofold: 1) teleological

information should not interfere with the envisioning process but can later be applied to search through the complete envisionment. 2) if functional assumptions are used to bias the simulation, then the envisioner should have explicit awareness of them.

As an example of the first point, de Kleer (1985) introduces teleological knowledge of electrical circuits to help prune complete envisionments and thereby reduce the search involved in recognizing circuit configurations. His system, QUAL, employs local teleologies to parse the behaviors of individual components. For instance, a resistor that converts a voltage drop into current functions as a "v-sensor", while one that transforms current into a point voltage acts as an "i-to-v-couple". A resistor has 18 possible teleologies, and de Kleer warns that although it is tempting (and easy) to bias the model of any resistor to manifest any one of these purposes (and violate NFIS), a properly robust simulator will permit all 18 possibilities. Once the envisionment has halted, QUAL can then match the resistor's behavior to one of its functionalities. Teleology biases reasoning/recognition but not simulation. If, along a path of the envisionment, the behavior of a resistor fails to match each of the 18 options, then that interpretation gets pruned under the assumption that the circuit was efficiently designed and hence should not contain any functionless components. QUAL then exploits global teleologies across configurations of locally-parsed components to further reduce the interpretation set, and ultimately, to properly categorize the circuit.

Concerning the explicitness of assumptions, de Kleer (1979) follows in the footsteps of Stallman and Sussman (1977) by saving the dependencies and assumptions of causal inference. Furthermore, he developed the ATMS (de Kleer, 1986), which serves as "intelligent cache" in managing the assumptions of nonmonotonic reasoning. As described above, Forbus and Falkenhainer (1988) have used the ATMS to bolster the advance of QPE into complex domains. They follow NFIS to the letter by making their assumptions explicit and "pluggable". In sum, De Kleer has backed up his theoretical claims in (De Kleer and Brown, 1983) with both QUAL and the ATMS. The obvious (but currently unrealized) synthesis of the NFIS implications is a system that exploits an ATMS or similar truth-maintenance mechanism to manage *teleological* assumptions in physical reasoning.

Another interesting discussion by de Kleer and Brown (1983) concerns the representational gap between teleological knowledge and system behaviors. They bemoan the difficulty of automatically translating high-level goals such as "it has a snapping action" or "it makes noise" into behavioral constraints. Automated physiological criticism encounters the same problem in compiling teleologies into desired behaviors. For instance, the goal of carbon-dioxide dissipation from the blood does not necessarily require that all carbon-dioxide producers become hypoactive, and all consumers hyperactive; but this makes a good qualitative approximation as a somewhat ideal case.

### Structural Criticism Versus Recognition

This thesis departs from de Kleer's work by focusing on structural criticism rather than recognition. In the latter, teleologies are matched against behaviors in order to eliminate behavioral interpretations. A teleology

that matches none of the interpretations is rejected as a possible classification. Conversely, in criticism, a contradiction between system behavior and teleology simply indicates a problem that must be analyzed, explained and possibly corrected. Typically, a recognition system searches a space of teleologies for one that best fits the structures and behaviors of the artifact, while a structure critic assumes the teleology and scans the artifact's structural and behavioral topologies for supports and violations of that purpose. A critic may search a space of teleologies, but only to get different perspectives for system evaluation. For instance, it may criticize a circulatory system on the grounds of oxygen transfer, energy efficiency, heat-dissipation, or even material efficiency (i.e., minimize the amount of circulatory vasculature). In systems with a high degree of function sharing (e.g., physiological systems), many relevant teleologies will arise to provide diverse vantage points for criticism.

The introduction of qualitative simulation to structural criticism introduces a serious dilemma: if the envisionment of a system contains many interpretations, which of them do we criticize? Are we justified in denigrating a system because our qualitative model predicts that *some* of its possible behaviors are "bad" (relative to a given teleology)? Alternatively, can we praise a system for having a few good interpretations? The only obvious case is when either all interpretations satisfy or all violate the teleology. Furthermore, on which interpretations do we base our change recommendations? Do we focus on the violators that require the fewest modifications, or on those with the most blatant, costly or potentially-dangerous errors?

Unfortunately, any such focus could seriously threaten robustness. In circuit recognition, de Kleer prunes interpretations because he knows that only a small subset of them are "right". He assumes that the device was *properly* designed to achieve some function. Any interpretation that avoids teleological parsing is therefore wrong. For the task of recognition, robustness entails considering all possible teleological parses of each interpretation. As de Kleer's results indicate, few interpretations support such a parse. In contrast, a structure critic assumes that the system was *improperly* designed to achieve a known function (although a critic need not disregard or distrust an interpretation that satisfies the function). To a design critic, robustness signifies a careful analysis of every potential faulty behavior; and hence no interpretation should be pruned unless it violates a fundamental physical law (e.g., water flowing from a low to a high-pressure tank). Apparently, a robust qualitative critic cannot exploit a teleological bias for pruning envisionments. However, it may still utilize functional assumptions to focus the evaluation and explanation of each interpretation.

### Summary

In review, qualitative physics presents a significant tradeoff of accuracy for completeness. While some researchers such as Kuipers seek to improve the accuracy of envisionment, Forbus and others search for efficient means of exploiting its completeness. The tradeoff becomes especially noticeable when we attempt to scale up envisionment to complex devices. If

these devices are designed to achieve some purpose, then knowledge of that purpose can improve envisioning accuracy by pruning teleology-violating interpretations. Since circulatory systems are both complex and susceptible to teleological interpretation, we can expect to utilize teleology in criticizing them. However, the correctness assumptions of recognition are replaced by the incorrectness assumptions of structural criticism; and these suppositions provide little grounds for envisionment pruning. To achieve robustness, the qualitative critic must take full advantage of complete envisionment while simultaneously exploiting the teleological bias.

Hence, we must clarify and enrich the notion of teleology so as to exploit its explanatory and focusing power. Within an interpretation, there are many different subsets of the local behaviors that deserve attention, and many ways to link those behaviors into a causal story (Even a deterministic simulation needs a perspective from which to view the results.). Teleology provides a framework for these stories.

From de Kleer's amplifier to Forbus and Skorstad's heat pump to Kuipers' sodium-balance mechanism, qualitative physicists have employed teleology to govern the analysis of physical systems. However, each has used it in a different way; and only de Kleer has recognized its true power and formalized its bias - but only in the domain of electrical engineering, where a large set of commonly agreed upon teleologies previously existed. A more general theory of teleology is needed. By exploring physiology, a domain that exhibits many diverse teleologies and (at least) two perspectives for evaluating purposeful behavior, I hope to help clarify and formalize the impact of teleological context on the qualitative evaluation and explanation of physical systems.

## CHAPTER III

### THE BIPARTITE TELEOLOGY MODEL IN PRODUCER-CONSUMER NETWORKS

This chapter formalizes the Bipartite Teleological Model (BTM) for a certain class of systems: *producer-consumer networks*. It begins by defining producer-consumer networks and describing their structures and qualitative behaviors that have relevance for BIOTIC. Then, it formalizes BTM and illustrates its role in evaluating those behaviors, and in explaining them relative to the network's structure.

#### Qualitative Producer-Consumer Networks

For the purposes of this thesis, a *producer-consumer network* consists of *components* and a *medium* for transporting *entities* between them. The medium circulates by being transferred between a series of pump components interspersed throughout the system. Typical entities include heat, ions, and chemicals, while standard mediums include air, water, and blood. The entity exchanges occurring between mediums and components are driven by concentration gradients, with entities always passively diffusing from regions of denser to regions of sparser concentration. A component *produces* some entity X if X diffuses from the component into the medium; it *consumes* X if diffusion goes the other direction.

#### Salient Behaviors of Producer-Consumer Networks

Within producer-consumer networks, interesting behaviors happen at three different levels: pulsatile, steady-state and regulatory. Pulsatile activities determine the flow patterns throughout the network. Flows depend upon the pressure gradients between pumps, and upon the dominance relationships between pairs of simultaneously contracted pumps. A pump's qualitative state consists of an *amount* (of medium) - either *empty* or *full*; and a *contractility* - either *contracted* or *relaxed*. If pump1 is full and contracted, while pump2 is empty and relaxed, and both pumps are connected by a flowpath that lacks other intervening pumps, then pump1 can usually send flow to pump2. However, if (a) pump3 is also full and contracted, (b) the flowpath from pump3 to pump2 intersects the pump1-pump2 flowpath, although pump3 does not lie along the pump1-pump2 path, and (c) pump3's contractile pressure exceeds pump1's pressure, then pump3's flow to pump2 will prevent pump1 from sending to pump2 (see Figure 5). To model these pump interferences, BIOTIC keeps track of all the potential arithmetic relationships between the contractile strengths of different pumps. As shown

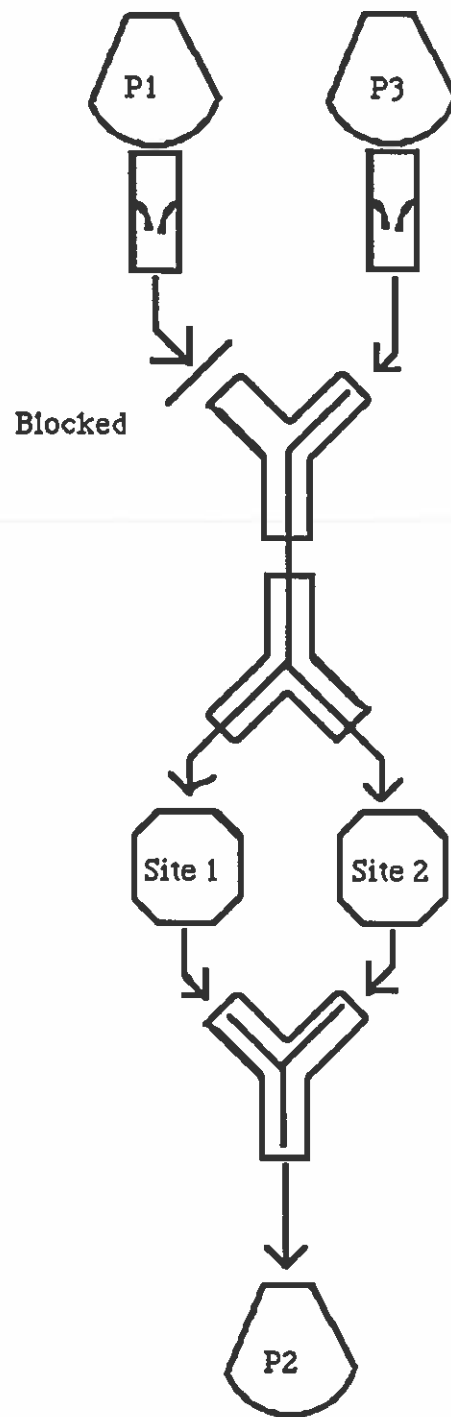

FIGURE 5. Competing pumps.

in the next chapter, this enables the flow simulator to envision all possible flow topologies. These topologies then exert a major influence upon the production and consumption behaviors at the steady-state and regulatory levels.

In BIOTIC, "steady state" refers to the fact that at any spatial location within the circulatory model, the qualitative flow rate holds constant relative to the coarse temporal granularity of a *characteristic cycle*. Essentially, the Producer-Consumer (PC) Topology generated by pulsatile abstraction involves a very coarse temporal grain in which one time unit denotes the duration of a characteristic cycle. At this granularity, a spatial point has a flow rate that represents the total amount of medium that passed it during the characteristic cycle; but for BIOTIC's simple qualitative representation, the flow rate at a point is [+] iff there is flow during at least one pulsatile sub-unit of the characteristic cycle. Since, by definition, the flow properties of a characteristic cycle are duplicated ad infinitum in successive "copies" of that cycle, the flow rate at any spatial point must hold constant across those copies. Thus, relative to the temporal granularity of a cycle, the unchanging qualitative flow rates of the PC Topology define a steady state.

In this steady state, the focal behaviors are the local consumption and production rates of various entities. Bipartite teleological analysis relies on a fairly simple qualitative representation of concentrations, gradients and exchange rates. The production or consumption level of an entity X at a component K depends upon two factors: the amount of medium perfusing K, and the concentration gradient of X between the incoming medium and K. Three concentrations of X in K are relevant:  $[X]^{K\text{-state}}$ , the component's internal concentration,  $[X]^{K\text{-in}}$ , the concentration in the incoming flow, and  $[X]^{K\text{-out}}$ , the concentration in the outgoing flow.  $G(X,K) = ([X]^{K\text{-state}} - [X]^{K\text{-in}})$  represents the diffusion gradient of X in K. When it is positive, K produces X; when negative, K consumes. BTM assumes that for any X and K,  $[X]^{K\text{-out}} = [X]^{K\text{-state}}$ , that is, relative to X, the medium always comes into equilibrium with the component before flowing out. This is called the *Diffusion Equilibrium Assumption* (DEA).

The quantity space for concentrations has three values: high, medium and low. A producer of X, P, will generally have  $[X]^{P\text{-state}} = \text{high}$ , while a consumer C will have  $[X]^{C\text{-state}} = \text{low}$ . Besides *exchange sites* (i.e., producers or consumers) the only other components where concentration gradients have relevance are flow mixers. The zero-order mixing rule is quite simple: the output concentration takes the qualitative value of the input concentrations if they are qualitatively equal; otherwise, it takes the value "medium". Hence, the mixing of a high and low concentration produces a medium concentration (as shown in Figure 1).

The diffusion gradient of X at K,  $G(K,X)$ , has a quantity space of five values: high positive, low positive, zero, low negative, and high negative. It derives from  $[X]^{K\text{-state}}$  and  $[X]^{K\text{-in}}$  according to Table 1.

In Table 1, a high positive gradient indicates the high production of X, while a low positive gradient signals a low production level. Similarly, a high negative gradient entails high consumption, and so on. During zero-order analysis, the gradients solely determine the consumption and production levels. As long as flow exists, it is assumed adequate for the component's needs.



TABLE 1. Qualitative Diffusion Gradients Based on Input and State Concs

[X]-input	[X]-state		
	High	Medium	Low
High	Zero	Low Negative	High Negative
Medium	Low Positive	Zero	Low Negative
Low	High Positive	Low Positive	Zero

During dynamic/regulatory analysis, the salient behaviors are (a) potential changes in exchange-site diffusion levels, called *tendencies*, (b) changes in the resistances of exchange sites, and (c) changes in flows caused by the resistance deviations. For instance, during exercise, heavy breathing raises oxygen concentrations within the lung and thereby incurs the tendency of increased oxygen production, while elevated metabolic rates often decrease tissue oxygen concentration, causing muscles to tend toward higher oxygen consumption.

In response to these alterations in diffusion potential, and in accordance with the "preferences" of the active teleology, components act in a local regulatory manner by changing their resistances. These modifications alter flow amounts network-wide by raising or lowering the flow outputs of each pump, and by shifting the distribution of flow within parallel regions.

Returning to the exercise example, the tendencies of the lungs and muscles would cause resistance reductions in each region, causing rises in blood flow. We could then interpret the resistance-changing regulatory action as one that enhances the teleology of oxygen transport since it increases blood flow to hyperactive producers and consumers.

Formally, dynamic analysis deals with *influences* : causal relationships wherein a change in one parameter encourages changes in one or more other parameters. Influences, along with the sensitivities that enable them are discussed more thoroughly in the next chapter.

In sum, the quintessential behaviors for bipartite teleological analysis of producer-consumer networks are the exchange rates of entities at local sites. These depend upon flows and concentration gradients. Flows, in turn, depend upon pump behaviors at the pulsatile level; and as detailed in the next chapter, once flow patterns have been determined, the pulsatile level can be ignored during both steady-state and regulatory analysis. Conversely, qualitative concentration gradients are easily calculated at the steady-state level under the Diffusion Equilibrium Assumption. Finally, during regulatory simulation, flows change in response to resistance changes, which are governed by exchange tendencies and teleological biases.

## The Contribution of Flow Topology to Exchange Behavior

In producer-consumer networks, the spatial relationships between exchange sites along flows are major determinants of behavior and teleological fulfillment. The exchange of entities at any given site vitally depends upon the exchange sites upstream, downstream and in parallel to it. I will refer to these relationships as *topological*. When viewed from this spatial angle, the producer-consumer network becomes the *producer-consumer (PC) topology*. In the circulatory analysis performed by BIOTIC, topological relationships are the cornerstones of causal activity and the focal points of structural criticism.

Consider the simple producer-consumer network of Figure 6. The medium arrives at the producer, P, with  $[X]^{P-in} = \text{low}$ . This creates a high positive diffusion gradient at P ( $G(P,X) = \text{high positive}$ ), which entails high production. Thus, the medium receives a large amount of X from the producer before exiting with  $[X]^{out} = \text{high}$ . It then enters the consumer, C, with  $[X]^{C-in} = \text{high}$ , which implies that  $G(C,X) = \text{high negative}$ , which leads to high consumption. The medium then leaves with  $[X]^{C-out} = \text{low}$  and cycles back to the producer.

Now witness a similar network (see Figure 7) without the valves. The resulting "sloshing" behavior is quite different from the simple cycle of Figure 6. With the slosh, each exchange site receives  $[X]^{in} = \text{medium}$ , which leads to low diffusion gradients and hence low exchange. Furthermore, although each site now receives two flows per cycle, each flow contains only half as much medium as in the simple-loop case. Hence, in both examples, each component receives the same average amount of flow per time unit, but the sloshed flows have a considerably lower diffusion potential.

The critical point is that in the simple loop, the exchange sites lie in series to one another, while in the slosh, they are parallel. Parallelism leads to the mixing that occurs in both pumps, and the mixing causes the low exchange gradients. Without a teleological bias, we cannot say whether this mixing is "good" or "bad", but it is clearly a significant departure from the simple loop behavior, even though the basic structural arrangements of the two networks are very similar. However, the resulting flow topologies are the crucial factors in analyzing those structures, not the superficial structural similarities.

Of course, one quick look at the structural arrangement should give a clear indication of the ensuing flow topology - thereby circumventing the need for pulsatile simulation, particularly if one is only interested in the qualitative results of pulsatile analysis; i.e., flow or no flow? Unfortunately, this is only wishful thinking. As hinted earlier, the relationships between pump strengths and contractile patterns play a major role in determining flow topologies.

For instance, consider the circulatory system of the crocodile as depicted in Figure 8. Assume that in this example, as in most circulatory systems, the hearts contract and relax simultaneously, while the veins, also modeled as pumps, simultaneously relax while the hearts contract, and contract when they relax. As detailed thoroughly in the next chapter, the structure of this model makes it necessary to consider three distinct qualitative states based on the relative contractile pressures of the two hearts:

1. Pressure (LH)  $\ll$  Pressure (RH) - The left heart is "considerably weaker" than the right heart.
2. Pressure (RH)  $\ll$  Pressure (LH) - The right heart is the weaker one.
3. Pressure (RH)  $\approx$  Pressure (LH) - The two hearts have "approximately equal" strengths.

Each state creates a different flow topology.

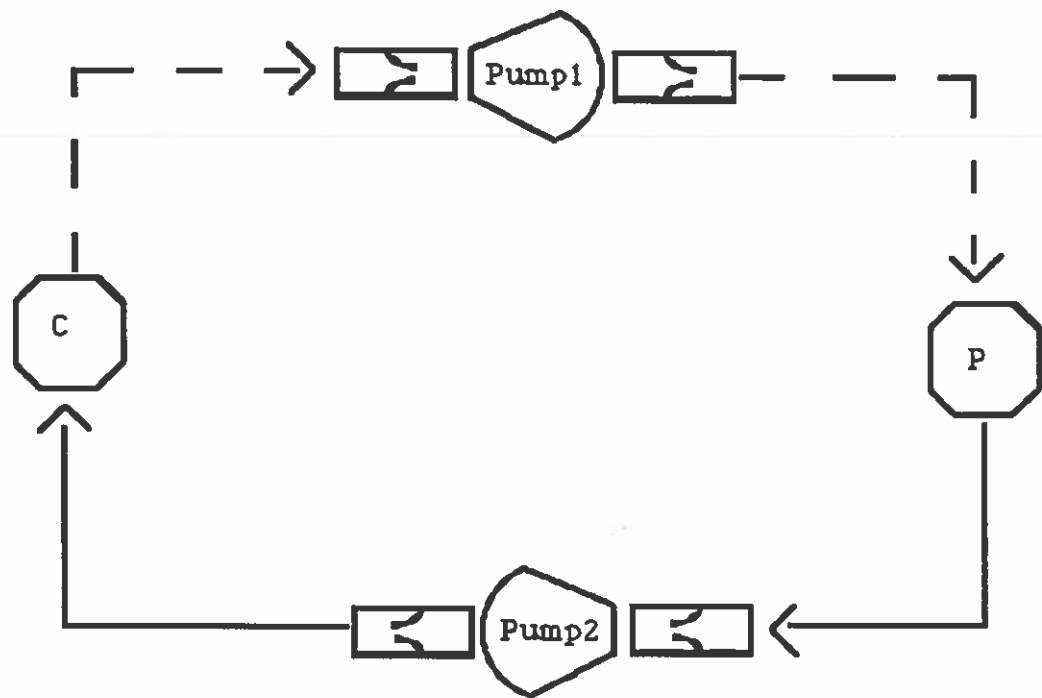

Legend:

C - consumer

P - producer

———— high concentration

- - - - - low concentration

FIGURE 6. Simple cyclic producer-consumer network.

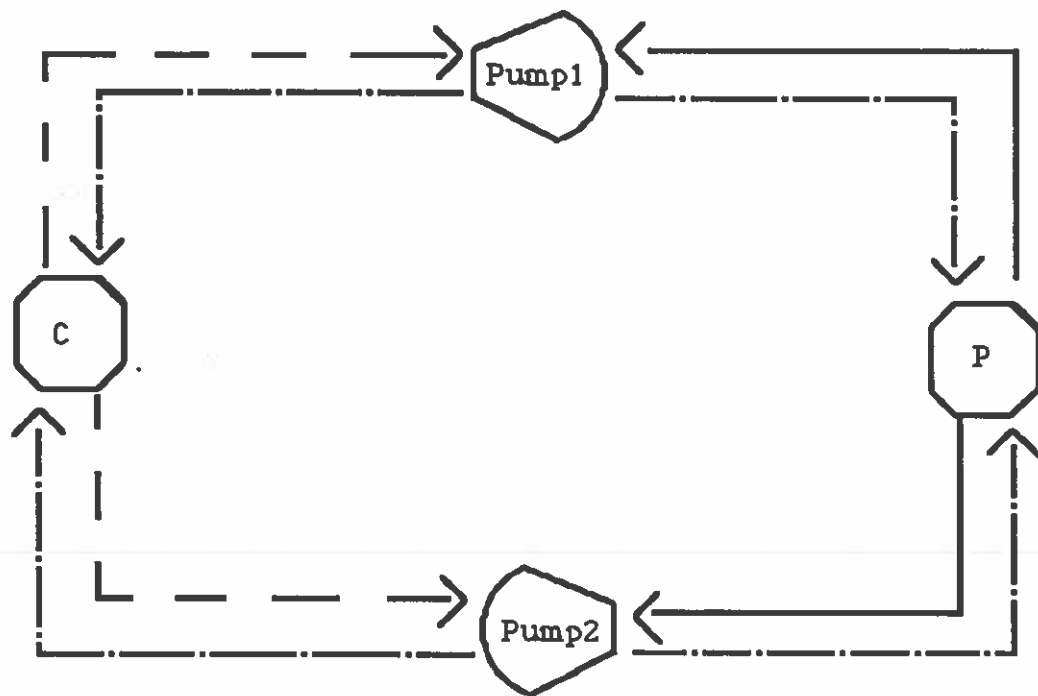

Legend:

C - consumer

P - producer

———— high concentration

- · - · - · - · - medium concentration

- - - - - low concentration

FIGURE 7. Sloshing producer-consumer network.

In case 1, the dominant right heart pumps blood both into the lungs and through valve 5<sup>2</sup> into the muscles. However, the powerful right heart's pressure blocks flow out of the left heart. Unable to expel blood, the left heart cannot receive blood either (according to the qualitative pulsatile assumption of an empty receiving pump). This forces a flow stoppage all the way back through the lungs to component T1. Hence, as shown in Figure 9, the only continuous flow is the loop from the right heart to the muscles and back. This brings the muscles into equilibrium with the incoming blood relative to entities such as oxygen and carbon dioxide. Hence, no exchange occurs. Clearly, this is not a useful flow topology for a living organism!

<sup>2</sup> Valve 5 and vessels v2 and v3 approximate the Foramen Panizzae of the crocodile, which connects the left and right aortae.

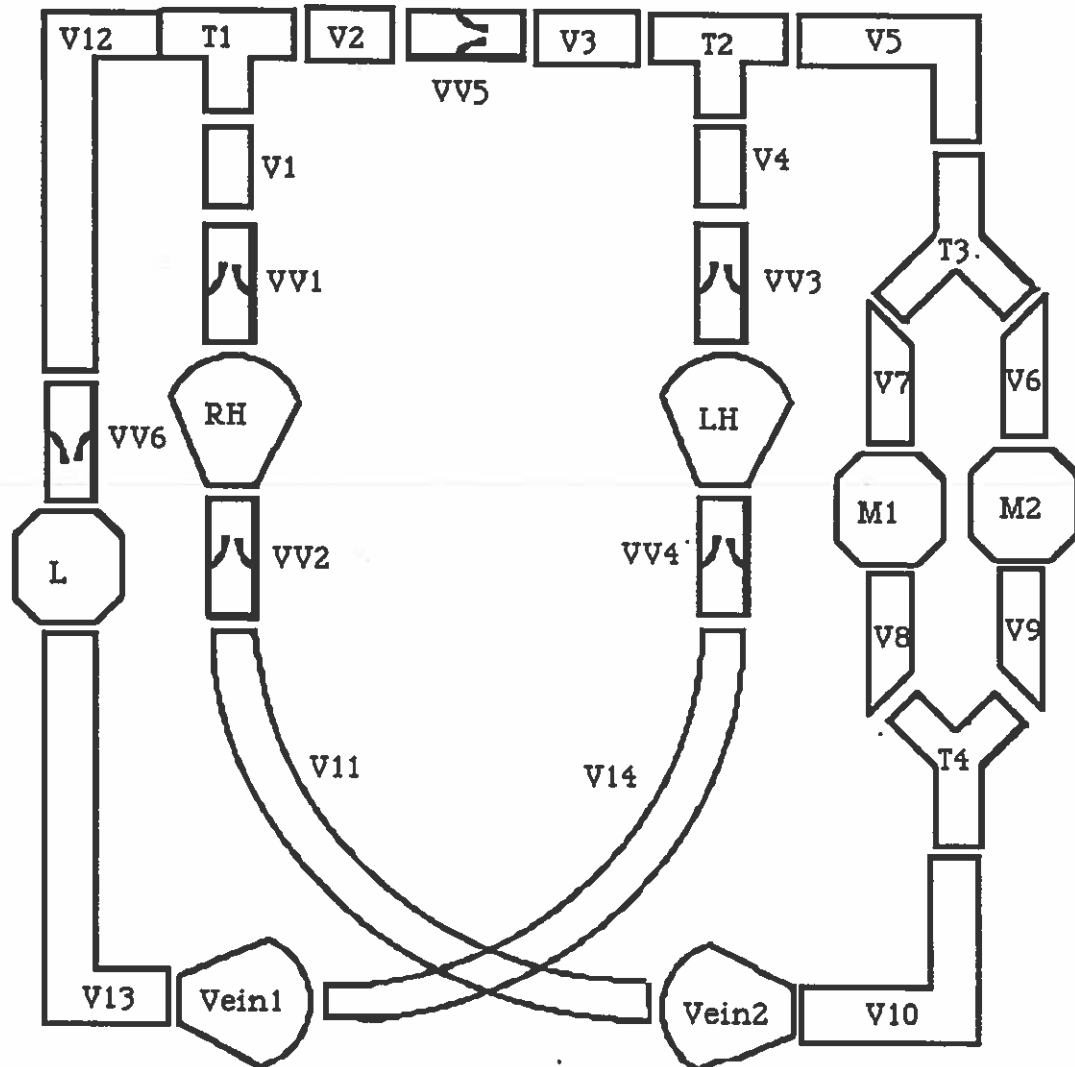

Legend:



- pump
- valve
- tissue
- RH - right heart
- LH - left heart
- L - lung
- M1,M2 - muscles
- VV - valve
- V - vessel
- T - 3-port vessel

Note: All other components are vessels

FIGURE 8. Crocodilian circulatory structure.

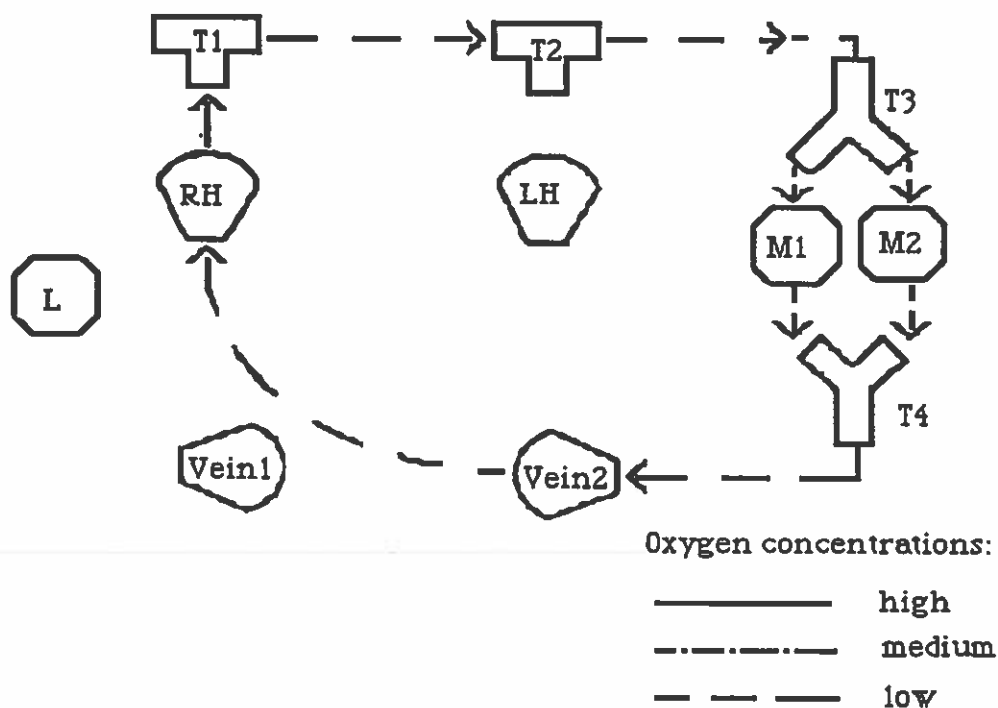

FIGURE 9. The incomplete crocodilian topology.

When the left heart overpowers the right heart, an entirely different topology ensues. The one-way valve VV5 prevents the left heart from pumping into the lungs and from blocking the right heart. However, the right heart cannot pump through VV5 either, because the pressure at T2 (induced by LH) greatly exceeds that at T1. Thus, the right heart pumps only to the lungs, and the left heart only to the muscles to create the figure-eight flow pattern of Figure 10. In this topology, the oxygen-consuming muscles receive a high incoming oxygen concentration ( $[O_2]^{M-in} = \text{high}$ ), while in the oxygen-producing lungs,  $[O_2]^{L-in} = \text{high}$ . Thus, high consumption occurs in the muscles, and high production in the lungs.

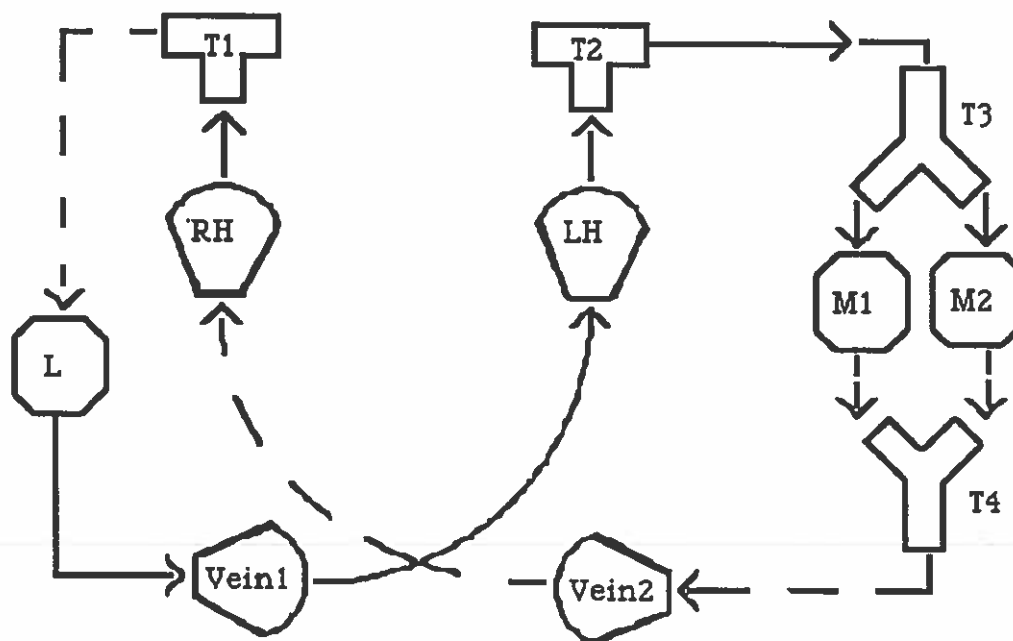

FIGURE 10. The serial crocodilian topology.

Finally, when the heart strengths are relatively equal, both hearts can send flow to the muscles, while RH can also pump to the lungs. In these networks, I make the qualitative assumption that when pump strengths are approximately equal, the pumps do not block one another unless they try to send flows in opposite directions through the same component. This topology causes the mixing of left and right-heart blood at T2 and places the lungs and muscles in parallel relative to the flow emanating from the right heart (see Figure 11). However, note that the mixing is only felt in the muscles, who receive a medium  $[O_2]^{in}$ ; in the lungs  $[O_2]^{in}$  remains low and enables high production.

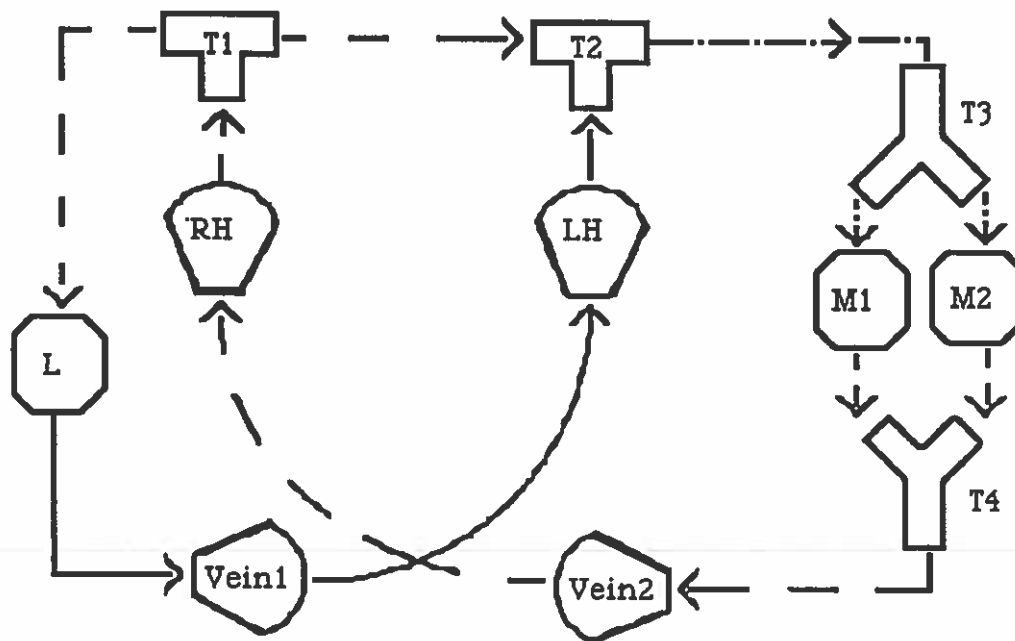

FIGURE 11. The parallel crocodilian topology.

Each of these three topologies corresponds to an interpretation of the flow environment. I call these the "incomplete", "serial" and "parallel" topologies, respectively, since the first delivers blood only to the muscles, the second circulates to both regions in series, and the third serves them in parallel. The crocodilian circulation colorfully exemplifies three key points:

1. The exchange behaviors of components are directly tied to the flow topology.
2. The flow topology is determined by both the static structure of interconnected components and the relationships between pump pressures and contractility patterns.
3. Within any given static component arrangement, many different flow topologies may occur (Experiments show that actual crocodilian circulations switch between parallel and serial topologies depending upon the demands of the muscles and lungs.).

One fundamental goal of this research is to automate the recognition of the primary topological relationships within a producer-consumer network, and to explain how those relationships contribute to entity-exchange behavior and to teleological satisfaction (or violation). This integration of global structure, behavior and teleology is the key to mechanized circulatory criticism.



### Formalized Topological Relationships

Two types of relationships characterize the PC topology: *communication* and *flowpath*. A communication relationship between two components implies that the concentrations of various entities within one component will affect the exchange rates of those entities at the other component. A flowpath relationship describes the relative spatial orientations of components along a flow or flow series, where a *flow* denotes a one-way transfer of blood from a sending pump to one or more receiving pumps.

Communication relationships are easy to spot. Since BTM relies on the Diffusion Equilibrium Assumption, the effects of an upstream site's state concentrations are only felt by the nearest downstream sites, which in turn put their state concentrations into the passing medium and effectively "overwrite the concentration message" sent by the original upstream site,  $S_{U1}$ . From the concentration standpoint, all of  $S_{U1}$ 's causal efficacy gets absorbed in the entity-exchange rates of the immediate downstream sites. Conversely, mixers do not absorb this efficacy, but combine it with another site's (or mixer's) message and pass on the conjunctive effect.

To continue this message-passing metaphor,  $S_{U1}$  *signals* another component (relative to some entity X) iff that component receives  $S_{U1}$ 's concentration-of-X (i.e., [X]) message. For a given entity, the collection of signals/messages that an exchange site receives constitute its *feed*. A *unique* feed contains a single signal, while a *non-unique* feed contains multiple signals and indicates that the site lies immediately downstream (i.e., no intervening exchange sites) from a mixer. Furthermore, a feed is *pure* iff all of its signals come from sites of the same exchange type. A *pure-p* feed has only producers as signal senders, while a *pure-c* feed comes from consumers. Finally, an exchange site exhibits *feedback* iff it signals itself; i.e., its outgoing concentration flows past no other exchange sites (although mixers may intervene) before looping back to the sender.

As examples of communication relationships, examine the three crocodilian topologies (of Figures 9,10 and 11) and consider feed properties relative to the entity oxygen. In the incomplete topology, each muscle receives a non-unique, pure-c feed and exhibits feedback. In the serial topology, the lung receives non-unique pure-c feed, while the muscles have unique, pure-p feed; no feedback occurs. Finally, in the parallel topology, the muscles feed back on themselves, but each has a non-unique, impure feed, due to the mixing of oxygenated and deoxygenated blood at T2. However, the lung still receives a non-unique, pure-c feed.

The communication relationships within a PC topology indicate groups of exchange sites with inter-dependent diffusion behaviors. For instance, if a consumer lies immediately downstream from a producer (and therefore has a pure-p feed), then it should receive a high incoming concentration and therefore attain a high consumption level. Furthermore, a rise in the producer's state concentration will increase both production and the consumer's incoming concentration - thereby raising consumption also. However, feedback precludes a high exchange rate, since, at best, the site with feedback will receive a mixed/medium incoming concentration (e.g., the

muscles in the parallel topology); at worst it will receive its own outgoing concentration as input (e.g., the incomplete topology muscles). Clearly then, communication relationships, which highlight intertwined producer-consumer behaviors, form critical pieces of a global understanding of system behavior and function.

*Flowpath* relationships also contribute to this gestalt understanding. Along a *flow*, two exchange sites lie in *absolute series* iff the same portion of the medium (i.e., the exact same medium molecules) flows through each site. A *direct serial* relationship demands absolute serialism, and both sites must lie along the same *flow*. The sites are *directly parallel* iff they lie along opposite branches of a flow-splitting component, and no pumps intervene between the split and the components. Two sites are *indirectly* serial or parallel if either or both sites reside within an aggregate of parallel or serial sites, and that aggregate is parallel or serial to the other site (or its aggregate). Furthermore, under the assumption that no system components have capacitance, serial relationships may extend across flows, since the medium molecules that enter a receiving pump will all leave when that pump becomes a flow sender. This constitutes an *extended* serial relationship. Extended serial relationships can be absolute, but not direct. Extended parallelism has no relevance, since the key characteristic of parallel exchange sites is their ability, through resistance changes, to alter one another's perfusion rates (i.e., the amount of incoming medium). This occurs as an indirect result of Kirchoff's Voltage Law (KVL), or the proper hemodynamic or pneumatic equivalent. However, when sites reside within distinct flows, a pressure source naturally intervenes between them, and KVL no longer holds. Hence, inter-flow parallelism incurs no perfusion-coupling.

In general, the flowpath relationship between two sites indicates the degree to which they can affect one another's perfusion rates. For instance, if two sites are directly serial and one raises its resistance to flow, the other site will also experience a flow decrease. However, if the sites are directly parallel, the resistance increase should redistribute flow away from the increase and toward the other site. For *indirect* flowpath relationships, the coupling of the two perfusion rates weakens, since the behaviors of other sites within the aggregate(s) also come into play. For example, in the parallel crocodilian topology, M1 and M2 are directly parallel. Hence, a rise in M1's resistance, while M2's remains constant, should decrease M1's perfusion while increasing M2's (under the assumption that pump outputs remain constant). However, M1 and L are only indirectly parallel, due to M1's participation in the M1-M2 aggregate. Therefore, an increase in M1's resistance and a steady L resistance do not guarantee an increase in L's perfusion, since another factor, M2's resistance change, must also be considered. If it falls, the net qualitative effect of the aggregate will be no resistance change (assuming that all local resistance changes are of equal degree), and hence no flow-distribution changes outside of the aggregate.

In summary, the topological relationships between exchange sites wield a heavy influence upon producer-consumer behavior. Hence, automated circulatory criticism demands the recognition and classification of these relations. To this end, I have divided them into two types: *communication* and *flowpath*. The former indicate the coupling of exchange sites via entity concentrations, while the latter characterize interdependencies of perfusion rates.

The two types of relationships are fairly independent, since the mechanisms that affect flow rates generally do not directly affect concentrations, and vice versa. For instance, pumps and flow-splitting components drastically affects flow rates but usually do not alter entity concentrations. Similarly, exchange-site *tendencies* directly affect diffusion per unit of perfused medium, but not the average medium flow. The notable exception to this independence is a flow mixer (e.g., T2 in the parallel crocodilian topology), where changes in flow along either of the input flow arms can change the output concentration.

At any rate, a fundamental hypothesis behind this research is that communication and flowpath relations are critical to an understanding of the behavior and function of producer-consumer networks, and furthermore that explanations grounded in these topological relationships convey the essential gestalt properties of such networks. The writings of Burggren (1987), Eckert, Randall and Augustine (1988) and other physiologists support this hypothesis, since their circulatory critiques highlight pivotal communication and flowpath relationships; and a relatively straightforward qualitative analysis of different topologies clearly illustrates the tight dependence between exchange behaviors and flow patterns. By clarifying these topological notions, we gain a formal model of the relationship between structure and behavior in producer-consumer networks. Next, to criticize these networks, we must connect the behaviors to purposes via the Bipartite Teleology Model.

### The Bipartite Teleology Model

Having discussed the basic qualitative properties of producer-consumer networks, as modeled in BIOTIC, and the relationships between behavior and structure within them, I now wish to introduce the Bipartite Teleology Model (BTM). This model of dual-perspective purposefulness provides a formal bias for the evaluation, explanation and (to a small degree) simulation of producer-consumer networks. Furthermore, it explicates some of the tacit teleological assumptions used by physiologists - thereby molding a conceptual framework for the integration of structure, behavior and function in circulatory analysis.

In a nutshell, BTM consists of a few generic teleologies. Producer-consumer networks can satisfy or violate these teleologies from either the dynamic or static perspective. BTM evaluates teleological attainment by comparing a teleology's behavioral *recommendations* to the actual results of qualitative simulation. During static analysis, these recommendations are used only to evaluate the simulation results; but in dynamic analysis, BTM actually biases the simulation by advocating certain resistance changes in response to exchange-site *tendencies*. Finally, during the explanation phase of criticism, BTM recommends teleology-dependent topological relationships, which provide a framework for the causal interpretation of producer-consumer behaviors.

### The Basic Teleologies of BTM

For any entity, X, BTM recognizes four basic teleologies: *transport*, *conservation*, *accumulation* and *dissipation*. These embody purposes that frequently appear in published physiological analyses. For instance, the circulation is often viewed as an *oxygen-transport* system or, in other contexts, as a heat *accumulation* or *dissipation* system. Similarly, the kidneys frequently function to *dissipate* water, salt and urea from the blood. On other occasions (i.e., when water intake is low), the kidneys *conserve* water by employing a countercurrent mechanism within the loop of Henle to *accumulate* salt and urea in the outgoing urine. Furthermore, these teleologies possess sufficient generality to encompass many types of producer-consumer networks such as steam plants, heat pumps, and various atmospheric circulatory models that track the movements of water, carbon-dioxide, oxygen, etc. between land, ocean and air.

A system transports X if the medium continually receives X at one or more producers and delivers it to active consumers. On the other hand, conservation entails very little production or consumption. Accumulation implies a buildup of X in the medium. That is, from the zero-order perspective, the concentration of X (i.e., [X] ) should be qualitatively higher than normal, while, from the dynamic perspective, actions should be taken to raise [X], or at least to keep it from falling. Similarly, dissipation denotes a low, falling, or non-increasing [X] in the medium, depending upon the perspective.

These four teleologies constitute goals/standards for the evaluation of producer-consumer networks. Each teleology compiles into local qualitative behavioral subgoals at the exchange sites. In steady-state analysis, these subgoal behaviors are concentration gradients and binary perfusion rates (i.e., flow or no flow), while in regulatory analysis, teleologies focus on exchange *tendencies* and perfusion derivatives. Essentially, zero-order evaluation focuses on the isolated qualitative values of exchange-site parameters; but regulatory assessment scrutinizes the relationships between tendencies and perfusion changes. These relations indicate the reactive capabilities of the network.

### Steady-State Evaluation Criteria

Steady-state analysis relies upon the Diffusion Equilibrium Assumption along with a few others:

1. Producers of an entity X always have  $[X]^{state} = \text{"high"}$ .
2. Consumers of X always have  $[X]^{state} = \text{"low"}$ .
3. The mere presence of flow at an exchange site indicates that sufficient flow perfuses that site.

These qualitative abstractions significantly reduce the complexity of simulating and critiquing producer-consumer networks while still

embodying essential behaviors. Certainly, finer granularities of qualitative behavior are possible, but they would only obscure the fundamental causal relationships between structure, behavior and teleology, and ultimately increase the difficulty of evaluating and explaining simulation results.

From the zero-order perspective, the salient behaviors of any producer or consumer are 1) whether or not the medium flows through them, and 2) the qualitative diffusion gradients of various entities. Different teleologies will prescribe different values for the flow and gradient parameters. From the static perspective, the "recommended" behaviors of the four basic teleologies appear in Table 2.

TABLE 2. Teleology-Recommended Flows and Gradients at Exchange Sites

Teleologies	Producer Flow	Consumer Flow	Producer Gradient	Consumer Gradient
Transport	Yes	Yes	High	High
Conserve	No	No	Zero, Low	Zero, Low
Dissipate	No	Yes	High	Zero, Low
Accumulate	Yes	No	Zero, Low	High

In Table 2, the absence of flow obviously precludes a diffusion gradient, so according to conservation, for instance, the optimal situation involves no flow to any exchange sites, but if there is flow, the gradients should be low.

The recommendations of the first two teleologies are fairly straightforward, but the latter two run contrary to intuition: accumulation would seem to require high producer gradients and low consumer gradients, and dissipation would demand the opposite. The problem is that these two teleologies have strong first-order connotations. Accumulation entails an increase or positive derivative (with respect to time), but from a steady-state view, accumulation means "high" not "rising". Similarly, dissipation means "low" not "falling". Remember, by assumption, producers always have a high internal concentration, and consumers a low one. If the gradient at a producer is low, then the incoming concentration must be fairly high, and only a low amount of production will occur (per unit of perfusing medium). In other words, little production is needed to maintain the already-high steady-state concentration. Thus, from the steady-state perspective, accumulation has occurred in a diffusion-driven environment when producers have small gradients but consumers have large ones. Similarly, low consumption and high production (per unit of perfusion) hint of dissipation.

The cardiovascular abnormality in human infants known as *Tetralogy of Fallot* (Guyton, 1986) clearly illustrates this conception of steady-state dissipative behavior. In *Tetralogy of Fallot*, various structural defects within the heart cause a *right-to-left shunt* in which blood from the right heart is

recirculated through the body instead of being passed to the lungs. (The parallel crocodilian topology exhibits a similar right-to-left shunt.) As a result, less blood gets reoxygenated than normal, but the blood that does make it to the lungs is very low in oxygen and hence forms a high gradient for oxygen diffusion. However, systemic (i.e., bodily) flow contains a mixture of oxygenated and deoxygenated blood and therefore forms a small gradient for oxygen consumption in the muscles. In sum, the oxygen producer has a large gradient, while the consumer has a small one; but oxygen has dissipated from the blood to cause the *blue baby* condition symptomatic of Tetralogy of Fallot.

In general, static evaluation focuses on concentration gradients. The assumption (i.e., number 3 above) of adequate flow implies that any deficiencies in static exchange rates stem from insufficient gradients. As an alternative, BTM could attach qualitative static flow demands to each site such as "high" "medium", "low" , etc. Then, a site with a high demand would have to lie in direct series with a pump, so as to receive all of its output; while lower demands could be met with flows that had been split. Unfortunately, this scheme demands an unbounded quantity space of flow amounts, because every time a flow splits, it decreases by a significant amount. Furthermore, circulatory physiology shows that even high-flow-demanding tissues lie many bifurcations downstream from the aortae leaving the heart. So, parallelism need not place restrictive upper bounds on static local perfusion rates; and hence, even though BTM could relate static flow demands to bifurcation distances from the nearest pump, the correlation (especially a qualitative one) would be dubious.

On the other hand, concentrations remain constant (qualitatively and quantitatively) during flow splitting. Thus, they are much easier to deal with than either flow amounts or absolute amounts of an entity (e.g., 4 grams of salt), both of which decrease during splitting. So, for qualitative modeling purposes, concentrations appear to be an informative focal parameter for the static analysis of producer-consumer networks.

### Regulatory Evaluation Criteria

From the dynamic/first-order perspective, producer-consumer networks are evaluated according to their ability to adjust to perturbations in a manner advocated by the teleology. In this mode, external perturbations cause producers and consumers to exhibit certain *tendencies* , such as increasing or decreasing their exchange rates. For example, at high altitude, the oxygen concentration within the lungs will decrease to show a tendency of decreased oxygen production. Teleologies determine the local behavioral changes that should occur in response to those tendencies, and first-order evaluation compares those prescriptions to the actual behaviors.

The Bipartite Teleology Model assumes that producer-consumer networks have a single local mechanism for reacting to the first-order tendencies: changing the resistance to medium flow of the site at which a tendency occurs. These changes can modify flow levels throughout the network, which in turn will alter exchange rates either in accordance or in conflict with the tendencies. This behavior mimics the ubiquitous physiological process of *autoregulation* (Guyton, 1986, pp. 234-235), in which tissues respond to changes

in their nutrient demands by altering their own resistances. The following Table 3 indicates the local qualitative flow changes recommended by the four teleologies in response to the six qualitative tendencies exhibited by exchange sites:

TABLE 3. Teleology-Recommended Flow-Change Responses to Exchange Tendencies

Teleo	$\partial\text{Prod}$ [-]	$\partial\text{CsmP}$ [-]	$\partial\text{Prod}$ [+]	$\partial\text{CsmP}$ [+]	$\partial\text{Prod}$ [0]	$\partial\text{CsmP}$ [0]
Trans	[-]	[-]	[+]	[+]	[0]	[0]
Cons	---	---	[-]	[-]	---	---
Diss	---	[-]	[-]	[+]	[-]	[+]
Accum.	[-]	---	[+]	[-]	[+]	[-]

So, from the dynamic perspective, each teleology advocates a different reaction to the exchange tendencies. For transport, the flow changes should vary in direct proportion to the exchange tendencies. This characterization of transport generalizes the well-known physiological concept of *ventilation-perfusion matching* (Guyton, 1986, pp. 490-491), which demands a direct proportionality between the amount of air that ventilates the lung and the amount of blood that perfuses the alveolar capillaries. Physiologists consider this matching (along with the dual match of perfusion to metabolism in other tissues) critical to the efficient transfer of oxygen and carbon dioxide between the lungs, muscles and organs.

Alternatively, conservation dictates a decrease in flow to all increasingly active exchange sites. Dissipation seeks to flood the stable and potentially hyper-active consumers but starve the producers, while accumulation has the opposite desires. These recommendations embody local attempts to continue pursuing the teleology in the face of perturbations. They are not guaranteed to work, however, since the global network topology may or may not permit the mutual satisfaction of these local goals. The resulting interactions between global topology and local resistance and flow changes form the basis for first-order criticism of the network.

As a brief example, consider two exchange sites residing in series. If one raises its resistance in the hopes of increasing local flow, while the other lowers its resistance, the net effect within the serial region will be no resistance change and hence neither site will see a change in flow. Serial relationships preclude disparate perfusion demands. During dynamic analysis, it is exactly these tight relationships between topology and local regulatory activity that require highlighting.

Once again, the basis for regulatory/first-order evaluation is the ability of a network to satisfy all of its local perfusion changes as recommended by the teleology in response to local exchange tendencies. Teleologies advocate resistance changes in the hopes of changing local flow, but these local regulatory mechanisms have only heuristic value, since the ultimate qualitative perfusion derivatives depend upon (a) resistance changes throughout the network, and (b) the flow topology that integrates those changes. A more advanced regulatory system might consider all of the flow demands before deciding on the appropriate resistance changes, but these complex systems lie beyond the scope of this research. Instead, BTM focuses on local regulatory actions, which further elaborate the critical relationships between topology, behavior and functionality in producer-consumer networks.

In review, The Bipartite Teleology Model provides a standard/bias for the evaluation of producer-consumer networks during both steady-state and dynamic behavior. The orthogonality of the four teleologies and two perspectives yields eight different angles for critiquing a network's behavior (relative to any entity). Once the interesting behaviors have been identified, a structure critic can use them to discern the network's salient topological formations.

#### Topological Recommendations of The Bipartite Teleology Model

Given a teleology and perspective, certain topological arrangements of exchange sites hold greater promise for satisfying their corresponding local evaluation criteria (as presented in the previous section). We can exploit these ties between topology and teleology to bias explanations of producer-consumer networks in terms of the topologies recommended by the focal teleology and perspective. The following section illustrates the teleology-topology associations of BTM, while the next chapter details their contribution to explanation in BIOTIC, the implemented system.

Within the Bipartite Teleology Model, the salient topological factors vary with the perspective. Specifically, the zero-order viewpoint focuses on the communication relationships between sites, while the first-order perspective deals primarily with flowpath concerns.

#### Static Perspective Topological Recommendations

From the static perspective, the four teleologies recommend the communication relations (relative to some entity) of Table 4.



TABLE 4. Teleology-Recommended Communication Relations

Teleology	Producer Feed	Consumer Feed	Producer Feedback	Consumer Feedback
Transport	PURE-C	PURE-P	No	No
Conserve	PURE-P	PURE-C	---	---
Dissipate	Pure-c	Pure-c or Mixed	NO	YES
Accumulate	Pure-p or Mixed	Pure-p	YES	NO

In Table 4, capitalized values represent the most salient prerequisites for each teleology. Hence, the critical aspect of zero-order transport is the existence of pure feed lines between producers and consumers, while conservation recommends no such feed lines (whether pure or mixed). For example, the serial crocodilian topology is ideal for oxygen and carbon-dioxide transport, since the producers receive pure-c feeds and the consumers get pure-p feeds. Alternatively, the incomplete crocodilian topology has the best conservative arrangement, since the muscles, as oxygen consumers, receive pure-c feed; and as carbon-dioxide producers, they accept a pure-p feed.

The keys to static dissipation and accumulation are feedback. When a consumer feeds back on itself, a propensity for dissipation exists, while producer feedback inspires static accumulation. For instance, in both tetralogy of fallot and the parallel crocodilian topology, the oxygen-consuming muscles feed back on themselves to create a static oxygen-dissipative situation; and from the carbon dioxide angle, these two topologies are accumulative.

#### Dynamic Perspective Topological Recommendations

From the first-order perspective, the correlations between topology and teleology are more context-sensitive. As shown in Table 3, the success of first-order behavior (relative to a teleology) relates to the ability to achieve certain perfusion changes in response to various exchange tendencies. Flowpath relations constrain those changes by requiring all directly serial sites to have equivalent qualitative perfusion derivatives. On the other hand, parallel relationships frequently permit the mutual satisfaction of different perfusion-change requests, although they cannot guarantee it. In short, the significance of a flowpath relationship will depend upon the teleology and the comparative tendencies of the two sites.

So, it makes little sense to say, for instance, that according to dynamic oxygen transport, producers and consumers should always be in parallel, because the normal environmental conditions may affect the network so that production and consumption tendencies are generally of the same qualitative magnitude. For example, humans rarely need to swim underwater for prolonged periods; most of our exercise occurs on land, where air is plentiful. Hence, we do not encounter many situations in which oxygen consumption rises but production falls (although one's rise may not quantitatively equal the other's, as during anaerobic activities). Only by factoring in the exchange tendencies (determined by the environment and the general tasks performed within it) can we make any speculations on teleologically-recommended topological relationships.

To come up with these recommendations, take each of the nine pairs of exchange tendencies (e.g., production up and consumption steady). Then, within each pair, look up the teleology-recommended flow change for each tendency in Table 3. If those changes are equal, then the production and consumption sites should reside in series, since serial relationships guarantee equivalent perfusion changes. If the recommended changes differ, a parallel relationship stands a good chance of satisfying both of them. Finally, if the teleology fails to make a perfusion recommendation for either site, then make no topological recommendation. The resulting cross-references appear in Table 5.

In Table 5, note that according to dynamic transport, when producers and consumers have similar tendencies, the optimal topology has them residing in series; but if their tendencies disagree, a parallel arrangement works better. Conversely, dynamic accumulation prefers a parallel relationship when both exchanges increase, since it seeks to flood the producer while starving the consumer; but, when production drops and consumption rises, a serial topology works best, since both tendencies demand reduced flow. As shown in upcoming chapters, these flowpath recommendations help guide the explanation of dynamic circulatory behavior.

TABLE 5. Teleology-Recommended Flowpath Relations According to Comparative Exchange Tendencies

Teleos	$\partial P \partial C$ + +	$\partial P \partial C$ + -	$\partial P \partial C$ + 0	$\partial P \partial C$ - +	$\partial P \partial C$ - -	$\partial P \partial C$ - 0	$\partial P \partial C$ 0 +	$\partial P \partial C$ 0 -	$\partial P \partial C$ 0 0
Trans	S	P	P	P	S	P	P	P	S
Cons	S	--	--	--	--	--	--	--	--
Diss	P	S	P	--	--	--	P	S	P
Accm	P	--	P	S	--	S	P	--	P

\* $\partial P$  = qualitative change in production;  $\partial C$  = qualitative change in consumption;  
 P = recommended parallel relationship between producers and consumers;  
 S = recommended absolute-serial relationship between producers and consumers.

### Summary

Looking back, this chapter began by describing producer-consumer networks and their salient behaviors and important global structures/topologies. Then the Bipartite Teleology Model was introduced as a bias for both evaluating the behaviors of producer-consumer networks and explaining those behaviors in terms of the network's flow topology. As illustrated, BTM provides a framework for the analysis of relatively complex qualitative models - a framework that integrates structure, behavior and function into a coherent picture of the gestalt system.

Obviously, BTM was designed with circulatory criticism in mind, although it appears to hold potential for many systems that fit the producer-consumer mold, and for many tasks that demand a bias for behavioral interpretation. Other potentially relevant domains include meteorology, thermodynamics, and other physiological systems such as the kidneys and intestines. Also, the fundamental distinction between steady-state and regulatory purposefulness applies to an ever-increasing number of situations. For instance, consider something as simple as bricks. These normally acts statically to support weight or to enforce a boundary. However, materials scientists have recently begun to develop "smart bricks" that react to environmental changes by altering their own colors and spatial orientations. In general, many contemporary engineering advances involve the injection of regulatory teleology into systems that previously had only static functionality.

Unfortunately, in this document, I can only speculate on the potential generality of BIOTIC and BTM. However, within circulatory criticism, BTM attains fairly widespread applicability by capturing many of the primal aspects of published critiques: diffusion behaviors, flow topologies, static purposefulness, dynamic purposefulness, etc. The next few chapters will show how these basic concepts are employed to automate circulatory criticism in BIOTIC.

## CHAPTER IV

### BIOTIC: THE BIOLOGY CRITIC

The previous chapter formalized Producer-Consumer Networks and the Bipartite Teleology Model. It also showed how topology, teleology and behavior intertwine. I will now discuss the operationalization of these concepts in the Biology Critic (BIOTIC), the implemented system behind this thesis.

BIOTIC inputs a qualitative circulatory model and a *critical context* in which to criticize that model. It then intermixes qualitative simulation and criticism to analyze the model. Both processes receive varying degrees of guidance from the critical context, which consists of five elements:

1. Teleology - A behavioral goal of the physiological system composed of a *critical entity* and a *critical action* (e.g., oxygen transport or heat dissipation).
2. Teleological Perspective - steady-state or regulatory.
3. Environment - External situation expressed as changes in the internal entity concentrations of various circulatory components; e.g., high altitude entails a lower oxygen concentration in the lungs.
4. Task - high-level endeavor such as running or swimming, which translates into activity-level changes of the circulatory components that assist in the performance of that task.
5. Flow Interpretation - global flow pattern determined by the contractility of circulatory pumps and the arithmetic relationships between the pressures of certain simultaneously contracted pumps.

BIOTIC outputs a *critique* composed of an *evaluation* and an *explanation*. Evaluations highlight local behaviors at exchange sites and how they agree or conflict with the teleology. Explanations describe the roles of topological relationships in determining those behaviors. As a whole, the critique conveys a comprehensive understanding of the circulatory model via the integration of structure, behavior and teleology.

Figure 12 summarizes BIOTIC's overall operation and illustrates the integration of structure, behavior and teleology. In a nutshell, the circulatory model and critical context are used by the simulator to generate flow topologies and diffusion behaviors. These behaviors then combine with the teleology during evaluation, and with the teleology and topology during explanation.

The two regions of Figure 12 coincide with the two main sections of this chapter. The first discusses the general procedures for qualitative simulation

of circulatory systems in BIOTIC. The second illustrates the automated criticism of the simulation's results. Detailed examples of these two processes appear in the next chapter.

### Qualitative Simulation in BIOTIC

Like most qualitative simulators, BIOTIC's circulatory simulator (CIRC-SIM) generates behaviors from a basic structural description and a few initializing behaviors. In this case, the structural description is a connected set of components, of which there are four primitive types:

1. Pumps - These propel blood through the system and also receive blood flows from other pumps. These are the only components that can have more than two ports.
2. Vessels - These simply transmit blood, although in some cases they may split one flow into two, or merge two flows into one. Next, CIRC-SIM
3. Valves - These block the flow of blood in exactly one direction. In the other direction, they behave as *straight* (i.e., two-port) vessels.
4. Tissues - These are the only components that produce or consume the vital entities (e.g., oxygen, carbon-dioxide, heat), and only tissues have a modeled resistance.

As start-up behaviors, CIRC-SIM requires the pumping patterns of all pumps and their initial amounts: either empty or full. Also, for every critical entity, CIRC-SIM demands the internal state concentration of that entity in each tissue.

From these simple beginnings, CIRC-SIM computes the pulsatile blood flows throughout the circulatory system. Due to ambiguities concerning the relative strengths of circulatory pumps (both hearts and veins are modeled as pumps), CIRC-SIM often produces many different possible flow patterns for a circulatory model, as most qualitative simulators would. To envision these possibilities, CIRC-SIM proceeds in the same spirit as Forbus's QPE (1986): it generates all relevant possible relationships between contracted-pump pressures; and then, for each set of consistent relationships, CIRC-SIM determines the resulting flows. Each combination of assumptions thus leads to one *flow interpretation*.

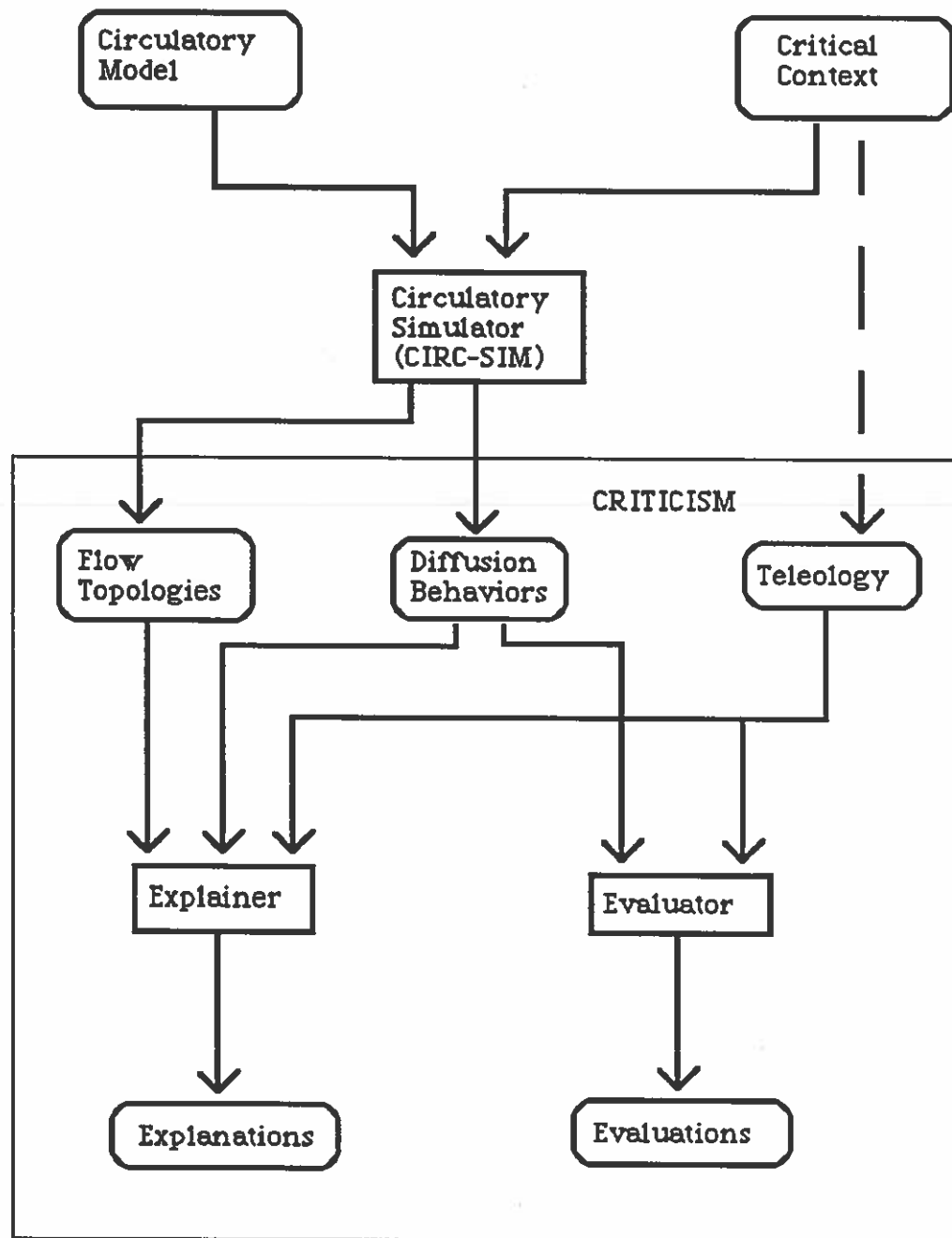

FIGURE 12. BIOTIC overview.

scans each flow interpretation for cyclic flow behavior. CIRC-SIM then restricts its attention to the flows of one cycle, called the *characteristic flows* of the interpretation.

For each interpretation, CIRC-SIM then performs temporal abstraction on its characteristic flows to yield a Directed Flow Network (DFN): a steady-state model of blood flow in the form of a directed cyclic graph representing the paths that a piece of blood takes through the system. BIOTIC then assigns roles to each of the components of a DFN to produce a Role Network (RN). Later, during static and regulatory analysis, BIOTIC uses the RN to (a) determine *communication* relationships between tissues/exchange sites, and (b) propagate critical-entity concentrations, their derivatives, and the derivatives of flow amounts.

Orthogonal to the temporal abstractor, a spatial aggregator parses each characteristic flow into a hierarchy of parallel and serial tissue aggregates. The combination of all such hierarchies across an interpretation's characteristic flows constitutes the Global Tissue Hierarchy (GTH) for that interpretation. From the GTH, BIOTIC discerns *flowpath* relationships between tissues. Furthermore, during dynamic analysis, BIOTIC employs the GTH to propagate changes in tissue' resistances and their concomitant changes in pump outputs and flow distributions. Together, the RN and GTH comprise the aforementioned *Producer-Consumer(PC) Topology* for the circulatory system.

After determining flows and abstracting them temporally and spatially, CIRC-SIM looks to the critical contexts for critical entities. Regardless of the teleological perspective, CIRC-SIM propagates each entity's qualitative concentrations throughout the RN to determine the zero-order exchange behaviors of each tissue. In zero-order simulation, CIRC-SIM usually ignores the environment and task while assuming "lab conditions" of negligible external perturbation. If the critical context calls for first-order simulation, CIRC-SIM also propagates qualitative *changes* in entity concentrations, resistances, and flows through the PC Topology. These changes are determined by the environment and task, and by teleology-driven reactions (as dictated by BTM) to the tissue' exchange *tendencies* invoked by the environment and task.

In summary, qualitative simulation in CIRC-SIM involves six general steps (also see Figure 13):

1. Pulsatile analysis.
2. Detection of flow cycles in pulsatile behavior to create a set of characteristic flows.
3. Temporal abstraction of the characteristic flows into a steady-state flow topology, the DFN.
4. Role assignment to DFN components to yield an RN.
5. Spatial aggregation of characteristic-flow tissue regions into a GTH.
6. Propagation of entity, flow and resistance information throughout the RN and GTH.

Steps 1, 3 and 6 closely mirror those taken by Collins and Forbus (1987) to integrate *piece-of-stuff* and *contained-liquid* ontologies for reasoning about fluids. They employ this combination to analyze thermodynamic cycles, which also qualify as producer-consumer networks. However, they focus on generating local behaviors and do not aggregate or parse the global flow topology so as to produce a more gestalt model of the system. They also shun teleology, which can further enhance the computer's global conception of a complex system. In order to perform physiological criticism, BIOTIC requires both a local and global understanding; it therefore demands a more comprehensive approach to liquid-flow analysis than that of Collins and Forbus. The following six sections describe each of the above steps in detail.

### Flow Envisionment: Generating the Pulsatile Topology

During flow envisionment, CIRC-SIM uses the pumping patterns of pumps along with assumptions about the relative strengths of those pumps to determine when and where blood transfers occur. In CIRC-SIM terminology, a *flow* is an event in which blood moves from one pump to one or more other pumps during a particular time interval. In most cases, the interval begins with the sending pump being full and ends with it being empty, while the receiving pump(s) go from empty to full. Furthermore, none of the receiving pumps may lie in series with another receiver along a unique flow.

In CIRC-SIM, both hearts and veins are modeled as pumps. This is fairly realistic, since, in living organisms, veins also act as pumps in returning blood to the heart. In fact, many physiology texts model pulsatile blood circulation as a heart-to-capillary-bed flow in combination with a vein-to-heart or "venous return" flow.

With each pump, CIRC-SIM receives a *history* of its pressure/contractility, where CIRC-SIM's histories are similar to those of Williams (1986). An *episode* is composed of an *event* and an *extent*, which denotes a closed interval of time points over which the event endures. For instance, the pumps in the crocodilian circulation (see Figure 8) have the following pressure histories:

RH: (contract 1 2) (relax 3 4) (contract 5 6) (relax 7 8)  
 LH: (contract 1 2) (relax 3 4) (contract 5 6) (relax 7 8)  
 Vein1: (relax 1 2) (contract 3 4) (relax 5 6) (contract 7 8)  
 Vein2: (relax 1 2) (contract 3 4) (relax 5 6) (contract 7 8)



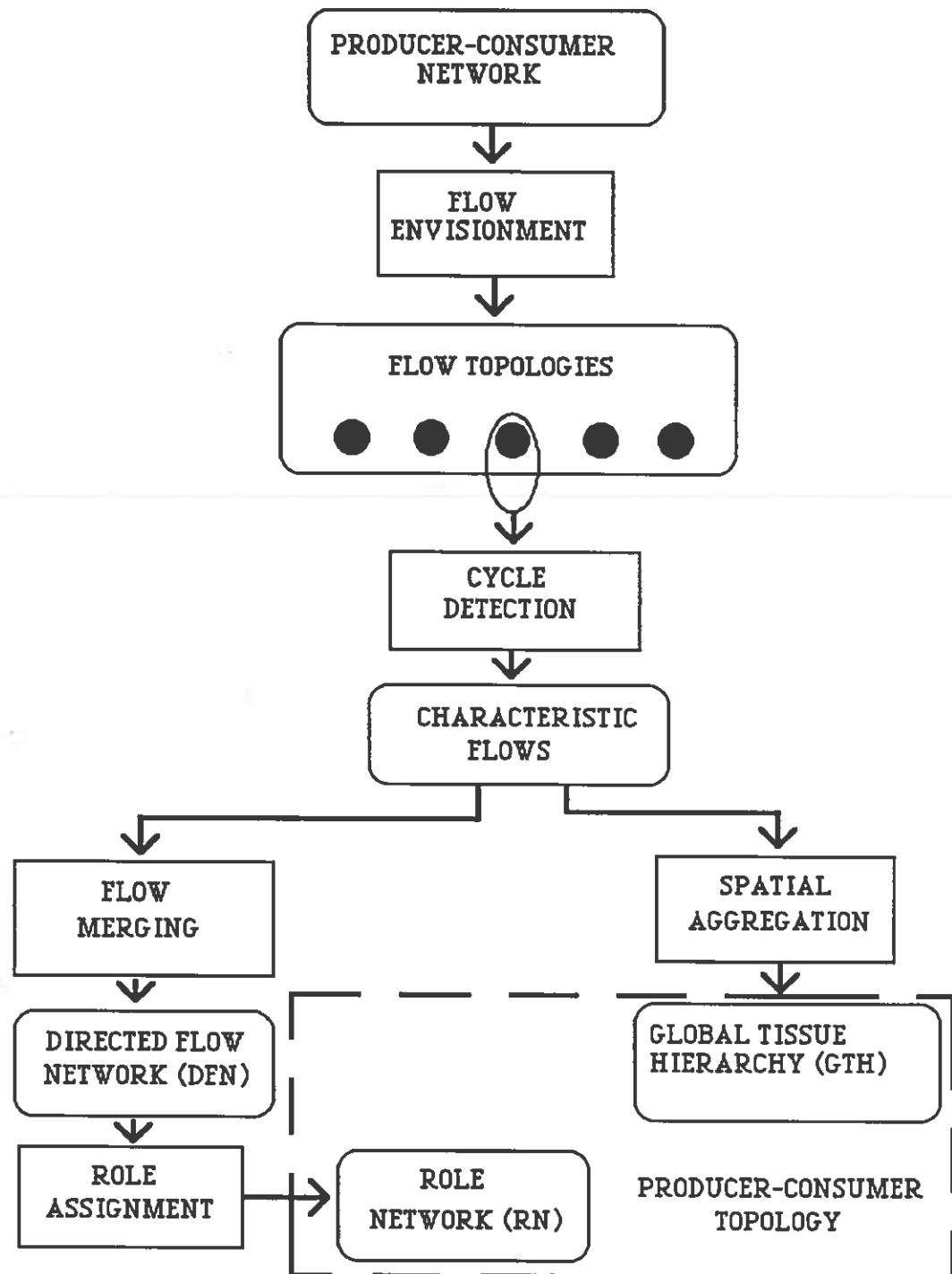

FIGURE 13. Pulsatile simulation and abstraction.

In other words, the right heart's contraction event occurs within the episode extending from time 1 to time 2; it relaxes over extent [3 4] , and so on. Also, CIRC-SIM needs the initial *amounts* of the four pumps:

RH - full, LH - full, Vein1 - empty, Vein2 - empty

Given the pressure histories and initial amounts, flow envisionment produces all of the possible pulsatile flow patterns. The details of flow envisionment are summarized in Procedures 1-10:

PROCEDURE 1: ENVISION-FLOWS()

- 1) Create a *contraction history* , C, in which each episode's event consists of a group of pumps that are simultaneously contracted during the extent of that episode. Every contraction episode of every pump should be incorporated into at least one of the contraction history's episodes.
- 2)  $\forall$  episode  $\in$  C do:
  - $\forall$  pump  $\in$  event(episode)
  - request-flow(pump, extent(episode))
- 3) QS  $\leftarrow$  generate-qualitative-states
- 4)  $\forall$  qs  $\in$  QS do:
  - a)  $\forall$  episode  $\in$  C do:
    - qs'  $\leftarrow$  update-qualitative-state(qs)
    - resolve-flow-requests(qs', episode)
    - flows  $\leftarrow$  build-flows(episode)
    - update-pump-amounts(flows)
  - b) reset-flowrequests

PROCEDURE 2: REQUEST-FLOW (pump, time-interval)

- $\forall$  comp  $\in$  adjacent-components(pump)
- pass-flow-request(comp, pump, pump, time-interval)

PROCEDURE 3: PASS-FLOW-REQUEST (comp, sender-comp, pump, time-interval)

If  
     Comp is a valve that does not permit flow in the desired direction  
 then  
     Reject the flow request and propagate that rejection back through sender-comp to the nearest potential flow splitter (i.e., a component that sent the same flow request to more than one neighboring component).  
 else  
     1) Cache the flow request (i.e., its sending pump and time) within comp.  
     2) If comp is a pump, then halt;  
     otherwise  
          $\forall$  neighbor  $\in$  adjacent-components(comp) - {sender-comp} do:  
             pass-flow-request(neighbor, comp, pump, time)

PROCEDURE 4: GENERATE-QUALITATIVE-STATES ( )

1)  $\forall$  comp  $\in$  components:  
      $\forall$  F1, F2  $\in$  flow-request-cache(comp):  
         if time(F1) = time(F2) and pump(F1)  $\neq$  pump(F2)  
         then pushnew((pump(F1) pump(F2)), pump-pairs)  
 2)  $\forall$  pair  $\in$  pump-pairs:  
     Generate a pump-relation triple consisting of three possible qualitative relationships between the contracted strengths of the two pumps:  $\gg$ ,  $\ll$ , and  $\approx$ . Push the triple onto pump-relation-triples.  
 3) Generate all arithmetically consistent combinations of pump-strength relationships that contain exactly one relationship from each of the pump-relation-triples.  
 4) Return the results of step 3.

PROCEDURE 5: PUSHNEW (elem, list)

If elem is not already a member of list, add it.

**PROCEDURE 6: UPDATE-QUALITATIVE-STATE (qual-state)**

- 1) Remove from qual-state all pump-strength relations in which the dominant pump has an amount equal to "empty".
- 2) Return the updated qualitative state.

**PROCEDURE 7: RESOLVE-FLOW-REQUESTS (qual-state, episode)**

$\forall$  comp  $\in$  components:

$\forall$  F1, F2  $\in$  flow-request-cache(comp):

if time(F1) = time(F2) = extent(episode) and pump(F1)  $\neq$  pump(F2)

THEN

1) Look up the pump(F1)-pump(F2) relationship in qual-state.

2) If one pump dominates the other

THEN, mark the dominating pump's flow request as "in", and mark the other as "out".

ELSE {i.e., pump strengths are qualitatively equal}

If F1 and F2 request flow in opposite directions across comp

THEN mark them both as "out"

ELSE mark them both as "in".

The general method behind these procedures is quite simple: to generate all flow topologies, send out all of the flow requests once (Procedures 2 and 3). Use flow requests that intersect in space and time to determine all of the relevant relationships between pump strengths. All consistent combinations of these relations form the set of qualitative states (Procedure 4) - each of which will determine one flow topology. Finally, cycle through the qualitative states and resolve flow requests (Procedure 7) in accordance with each such state. Various "in" flow requests join together to form the flows of a topology (Procedure 8).

PROCEDURE 8: BUILD-FLOWS (episode)

- 1)  $\forall C1, C2 \in$  components such that adjacent(C1,C2):
  - $\forall F1 \in$  flow-request-cache(C1) and  $\forall F2 \in$  flow-request-cache(C2):
    - If time(F1) = time(F2) = extent(episode) and pump(F1) = pump(F2)
    - and mark(F1) = mark(F2) = "in"
    - then Connect F1 and F2
- 2) Gather up the connected trees of "in" flow requests which begin at a single sender pump and end at one or more receiver pumps. Each such tree constitutes one of episode's flows.
- 3)  $\forall$  Flow  $\in$  flows(episode)
  - a)  $\forall P \in$  pump-receivers(Flow):
    - If amount(P)  $\neq$  "empty"
    - then
      - i) Prune all branches of Flow that lead only to P
      - ii) Remove P from pump-receivers(Flow)
  - b) If pump-receivers(Flow) = nil
    - then Remove Flow from flows(episode)
- 4) Return flows(episode).

PROCEDURE 9: UPDATE-PUMP-AMOUNTS (flows)

$\forall P \in$  pumps  
 if  $\exists F \in$  flows, such that  $P \in$  receiving-pumps(F)  
 then amount(P)  $\leftarrow$  "full"  
 else  
 if  $\exists F \in$  flows, such that  $P =$  sender-pump(F)  
 then amount(P)  $\leftarrow$  "empty"

PROCEDURE 10: RESET-FLOW-REQUESTS ( )

$\forall C \in$  components :  
 $\forall F \in$  flow-request-cache(C):  
 mark(F)  $\leftarrow$  "undecided"

In the abstract, this methodology resembles Forbus's use of closed-world tables during total envisionment in QPE (1986b). Basically, he inputs a model and immediately generates all possible combinations of relationships. He then employs an ATMS to manage those relationship assumptions while he simulates each of the combinations. However, whereas Forbus generates many inconsistent combinations, CIRC-SIM uses flow-request propagation to only

generate the relevant combinations of pump-strength-relation assumptions; i.e., only when two pump's flow requests intersect is it necessary to consider the strength relationships between them. Still, CIRC-SIM shares with QPE the common theme of getting a handle on all combinations of pivotal relationships before actually envisioning the system's low-level behavior. Although I have yet to integrate an ATMS into this phase of CIRC-SIM, the early gathering of assumptions paves the way for such an enhancement.

In review, the flow envisioner receives a circulatory system, its pumping histories, and the initial amounts of each pump. It then outputs all possible flow topologies/interpretations. Once again, the key point of flow envisionment is that each combination of pump-strength relations defines one interpretation. The more combinations, the more flow topologies, and the more possible producer-consumer behaviors within the system. For instance, in the crocodilian system, flow envisionment yields the three flow topologies of Figures 9 - 11. The key point of CIRC-SIM's envisionment algorithm is that it passes flow requests only once, but then resolves them in all possible ways determined by the pump-strength combinations.

#### Cycle Detection: Beginning the Temporal Abstraction

To detect cycles in a pulsatile flow topology, CIRC-SIM looks for similarities among pump states across time. During two different time intervals, a pump has the same state iff it has the same amount and the same flows entering and leaving it, where two flows are considered equivalent if they originate from the same pump. Two global states are equivalent exactly when each pump has equivalent states at the two times. A cycle is a sequence of global states  $s_1 \dots s_n$ , such that the next  $n$  states are  $s_{n+1} \dots s_{2n}$ , and  $\forall i \leq n$ ,  $s_i = s_{i+n}$ . A *minimal cycle* is one that cannot be partitioned into a sequence of smaller cycles, all of which are equivalent.

CIRC-SIM finds all minimal cycles and then chooses the longest of those as the *characteristic cycle* of the flow topology. The flows of that cycle constitute the *characteristic flows* of the topology. From this point forth, these are the only flows of importance to CIRC-SIM.

#### Flow Merging: Completing the Temporal Abstraction

During flow merging, CIRC-SIM pieces together the characteristic flows into a directed flow network (DFN). This essentially ignores each flow's temporality to represent a steady-state model of the circulation. Flows can be united both at their endpoints (i.e., their sending or receiving pumps) or internally. Endpoint merger is fairly trivial: if one flow enters a pump during an interval, and another flow exits that pump at the next "active interval" of the pump - namely, an interval in which the pump sends or receives flow - then the entering flow connects to the exiting flow. Also, if the exiting flow occurs during the pump's first active interval of the cycle, and the entering flow during the pump's last such interval, then the two are similarly united. This latter form of merging insures the closing of flow loops, some of which

may correspond to loops in the component topology, while others, such as some sloshing flows, simply move in two directions across the same linear segment of components.

Flows merge internally only when their time intervals overlap and they meet at a three-port vessel. For instance, in the parallel crocodilian topology (see Figure 11), flows from the left and right heart intersect at T2. When two flows intersect internally, their common flow region is modeled as a single directed pathway in the DFN. This unification pertains to the DFN and RN, but not to the GTH, which, as shown below, essentially ignore internal flow unions in dealing with each flow independently. Figures 9 - 11 depict the DFNs for each crocodilian topology. To simplify the drawings, only the relevant components are pictured even though, in the serial and parallel topologies, almost all components participate in the DFN.

After cycle detection and flow connection, the pulsatile model has been temporally abstracted into a directed flow network. This network represents a global flow pattern that blood repeatedly cycles through during the operation of the circulatory system. In building this network, CIRC-SIM abstracts out time by ignoring the temporal disparity between a pump's receiving and sending actions (it simply connects the two events together in the network and disregards any delays), and by ignoring the flow events that come later in time to merely repeat the basic flow cycle. Due to the nature of entity propagation (as discussed in a later section), one pass through this network suffices to calculate both the production-consumption behavior of the system and the changes to that behavior instigated by resistance and concentration perturbations.

### Role Assignment

At this point, CIRC-SIM can assign "roles" to each component. A component will assume a number of roles corresponding to the number of DFN flow arcs along which it lies. For instance, during a slosh, many components will lie along both opposite-direction flows. In the three crocodilian topologies, all components except the pumps have a single role; but that role may vary across interpretations.

As listed below, there are six fundamental producer-consumer roles (PCRs) that a component can play (in parentheses are the components that may assume each role):

1. Sender (pump) - initiates a flow.
2. Receiver (pump) - receives a flow.
3. Mixer (pump, vessel) - joins two DFN flow arcs into one arc.
4. Splitter (pump, vessel) - splits a DFN flow arc into two arcs.
5. Conduit (vessel, valve) - simply passes on a flow.
6. Diffuser (tissue) - produces or consumes one or more of the vital entities.

A pump serves as a sender when it sends flow in a single direction, but as a splitter when it initiates flow out of two ports. Similarly, it is a receiver when catching flow from one direction and a mixer when simultaneously accepting from multiple ports. A vessel acts as a conduit when it passes a flow from one port to another, but when there are two active input ports, it acts as a mixer; and two active output ports defines a splitter. By assumption, a component cannot mix and split flow at the same time. Finally, tissues always assume the role of diffuser.

CIRC-SIM moves through the directed flow network and assigns a new PCR to each component it encounters. It then hooks up the PCRs into a Role Network (RN), which has the same skeleton as the directed flow network but contains a frame/PCR to record each situation in which a DFN flow arc passes through a component. PCRs are linked to one another via "parent" and "child" fields, where a parent is the immediate upstream PCR, and a child is adjacent and downstream. Splitters have multiple children; mixers have multiple parents.

These roles account for the dynamic nature of system analysis and classification. In many cases, one cannot simply peruse the static structure of a circulatory model and determine the directionality of flows nor where they will split and join. During flow envisionment, the flow topologies become explicit, and the actual roles of components become clearer.

To illustrate role assignment in the crocodilian topologies of Figures 9 - 11, note that T1 serves as a conduit in the serial and incomplete interpretations but as a splitter in the parallel version. Similarly, T2 is a mixer in the parallel but a conduit in the other two topologies. T3 is a splitter in all three topologies, while T4 is always a mixer. The muscles are always diffusers, but the lung is only a diffuser in the serial and parallel accounts; in the incomplete topology, it lies along no flow paths in the DFN and therefore has no PCRs. The valves and two-port vessels are always conduits, unless they fail to appear in the flow network.

The Role Network now serves as the backbone for steady-state simulation (in particular, the passing of entity concentrations throughout the circulation), as well as for regulatory analysis.

### Spatial Aggregation: Generating the Global Tissue Hierarchy

During the simulation of *autoregulation*, the aforementioned physiological process in which tissue beds adjust their resistances in response to changing flow demands, CIRC-SIM must determine the effects of resistance changes upon blood circulation. To perform this type of simulation, CIRC-SIM must keep track of the hierarchical arrangement of tissue-beds/resistors along each flow. Then, when a resistance changes, its effects can be propagated upward through the parallel and serial resistor aggregates in which it participates, until ultimately it exerts a positive or negative influence upon the pump outputs that service it; and on the ascent through the hierarchy, those resistance changes may affect the distributions of blood among parallel regions.



CIRC-SIM builds the Global Tissue Hierarchy (GTH) by tracing each characteristic flow from its sender pump to each receiving pump. It then creates tissue aggregates (TAGGs) as spatial abstractions of tissue groups. When two or more tissues or TAGGs lie in series, they become part of a serial tissue unit (STU). If they reside in parallel, CIRC-SIM creates a parallel tissue unit (PTU). All TAGGs have a resistance field representing the aggregate resistance. TAGGs also keep track of the influences upon that resistance by the subordinate tissue and/or TAGG resistances. Furthermore, PTUs keep track of the influences upon the distribution of blood down each parallel branch. Each branch has a *distributor* field, which records those influences. In the end, all of the tissues along a flow get parsed into a hierarchy of containment among the tissues, STUs and PTUs. Each flow object keeps a pointer to this hierarchy for use during regulatory analysis.

In the crocodilian topologies, the GTH's are quite simple. In all three interpretations, M1 and M2 lie in parallel along a PTU that begins at T3 and ends at T4; call it PTU<sub>M</sub>, although it will take on a unique identity in each interpretation. In the incomplete topology, this is the only TAGG along the flow from RH to vein2. In the serial topology, PTU<sub>M</sub> is the sole TAGG along LH's flow to vein2, while L comprises the entire resistance hierarchy along RH's flow to vein1. The parallel topology is more interesting: PTU<sub>M</sub> lies along one branch of a PTU<sub>T1</sub>, which begins at T1. The lung comprises its other branch. This recursive PTU constitutes the tissue hierarchy for RH's flow to vein1 and vein2. In addition, PTU<sub>M</sub> acts as the tissue hierarchy for LH's flow to vein2. Even in the serial topology, the crocodilian model lacks an STU, since no two tissues or TAGGs lie in series along any single flow.

### Summary of Pulsatile Abstraction

CIRC-SIM uses temporal and spatial abstraction to transform each pulsatile flow topology into a Producer-Consumer Topology comprised of a Role Network and a Global Tissue Hierarchy. These abstractions simplify the later stages of simulation.

As a brief review of these abstraction processes, for each interpretation in the flow envisionment, CIRC-SIM scans the pulsatile behavior for the largest minimal cycle, whose flows become the characteristic flows of the interpretation. CIRC-SIM then merges the characteristic flows into a directed flow network (DFN), which abstracts out the pulsatile behavior to form a smooth global flow pattern. The DFN then serves as the skeleton for the Role Network, which assigns roles to the circulatory components. CIRC-SIM uses the RN as a pathway for the propagation of entity concentrations (during zero-order simulation) as well as changes in concentrations and flow amounts (during first-order simulation).

In forming the Global Tissue Hierarchy (GTH), CIRC-SIM parses each of the characteristic flows into parallel and serial tissue regions. During first-order simulation, the GTH transmits changes in tissue resistance throughout these regions and records the concomitant changes in flow distribution (i.e., how the flow amounts differ between the arms of a parallel region) and pump output (i.e., the total amount of blood transferred during a flow event).

## Propagating Information Throughout the PC Topology

CIRC-SIM passes four different types of qualitative information through the PC Topology: entity concentrations, entity-concentration derivatives, resistance derivatives, and flow derivatives. The passing of entity concentrations occurs as part of zero-order simulation, while derivative passing happens only during first-order analysis. The next two sections discuss zero-order and first-order information passing.

### Zero-Order Information Passing

The goal of zero-order propagation is to determine the qualitative exchange behavior of each tissue/site in the circulation, relative to a particular critical entity, X. To do so, CIRC-SIM must determine a value for each tissue's exchange gradient of X. As shown in Table 1, these gradients depend upon the tissue's state concentration and its incoming concentration of X. CIRC-SIM uses the tissue's type (i.e. lung, muscle, etc.) to determine  $[X]^{state}$  (e.g., lungs are assigned  $[Oxygen]^{state} = "high"$  and  $[Carbon-dioxide]^{state} = "low"$ ), while the computation of  $[X]^{in}$  requires entity passing.

During entity passing, CIRC-SIM relies upon the Diffusion Equilibrium Assumption (DEA) to insure that  $[X]^{out} = [X]^{state}$  for any X. This greatly simplifies entity passing by rendering it amenable to straightforward qualitative techniques. Without DEA, CIRC-SIM would have to repeatedly cycle concentrations through the RN until quiescent input and output concentrations were achieved. As shown by de Kleer and Brown (1985), qualitative reasoning about quiescence, even in simple systems, is a very difficult process. I have no intention of trying to scale up the envisioning nightmare of quiescent analysis to circulatory systems.

Entity passing occurs solely within the Role Network by moving from PCR to PCR along "child" links. To keep track of the different entities being passed, CIRC-SIM creates "diffins" (diffusion instances) and attaches one for each relevant entity to every diffuser PCR. Diffins then house the state and input concentrations of their designated entity, along with its diffusion gradient. Remember, a tissue may have multiple diffusers, and hence multiple diffins for the same entity, if it lies along multiple arcs of the DFN. A *relevant entity* is one that appears in any of the critical contexts that BIOTIC receives as input. So, for example, when a high concentration of heat enters a tissue diffuser, CIRC-SIM fetches the diffuser's heat diffin and records the incoming heat concentration (a.k.a. temperature) and computes a heat gradient. Similar attachments occur in the other types of PCRs to segregate the transport of different entities.

Furthermore, BIOTIC assumes that different entities will not interact to affect one another's exchange rates. Of course, this assumes away a good deal of fascinating physiology, since oxygen, carbon-dioxide and heat interact in very interesting (albeit complex) ways. But this presupposition is necessary to help elucidate the fundamental qualitative relationships between the PC Topology

and the production and consumption behaviors of tissues. Procedures 11 - 14 convey the essence of entity passing in CIRC-SIM.

PROCEDURE 11: PROPAGATE-ENTITY (entity)

```

∀ tissue ∈ tissues:
  ∀ diffuser ∈ diffusers(tissue):
    if mark(diffuser) = "updated" then nil
    else
      pass-entity(entity,
                    role-network-child(diffuser),
                    diffin-state-conc(diffuser-diffin(entity)))

```

As a brief summary of Procedures 11 - 14, CIRC-SIM starts at any tissue, K, and gathers all diffuser PCR's for K. It then passes  $[X]^{K\text{-state}}$  as the input concentration to the "child" PCR of each diffuser. The response of a PCR to an incoming concentration varies with the PCR. Senders, receivers, conduits and splitters cache simply pass it on to their child PCR's. Mixers wait until they have concentrations on both input arms before computing the output concentration and passing it on. Diffusers use the input to calculate a qualitative diffusion gradient and then pass on their own state concentrations. After a round of entity passing, if any diffuser has not been propagated through, it serves as the starting point for another transmission. Once each appropriate diffin (i.e., one pertaining to the entity being passed) has a diffusion gradient, entity passing halts. For example, the passing of oxygen through each of the crocodilian topologies yields the results of Tables 6-8.

**PROCEDURE 12: PASS-ENTITY (entity, pcr, qual-conc)**

If mark(pcr) = "updated" then halt

else

1) mark(pcr)  $\leftarrow$  "updated"

2) case type-of(pcr)

a) sender, receiver, conduit or splitter:

$\forall$  kid-pcr  $\in$  role-network-children(pcr):

pass-entity (entity, kid-pcr, qual-conc)

b) mixer

If the mixer has received entity's conc along both input ports,  
then

i) mix-conc  $\leftarrow$  qualitative-conc-mix(input-port-concs)

ii) pass-entity(entity, role-network-child(pcr), mix-conc)

else

Store entity and qual-conc on the input arm and halt entity  
passing. Basically, wait for the other arm to receive a  
concentration of entity.

c) diffuser

i) diffin  $\leftarrow$  diffuser-diffin(entity)

ii) diffin-in-conc(diffin)  $\leftarrow$  qual-conc

iii) calculate-diffusion-gradient(diffin)

iv) pass-entity(entity,  
role-network-child(pcr),  
diffin-state-conc(diffin))

**PROCEDURE 13: QUALITATIVE-CONC-MIX (conc1, conc2)**

If conc1 = conc2 return(conc1)

else return("medium")

**PROCEDURE 14: CALCULATE-DIFFUSION-GRADIENT (diffin)**

Use diffin-state-conc(diffin) and diffin-in-conc(diffin) as indices  
into Table 1.

TABLE 6. Exchange Behaviors of the Incomplete Crocodilian Topology

Tissue	[O <sub>2</sub> ]state	[O <sub>2</sub> ]in	O <sub>2</sub> -gradient	Exchange
Lung	high	none	none	none
M1	low	low	zero	zero
M2	low	low	zero	zero

TABLE 7. Exchange Behaviors of the Serial Crocodilian Topology

Tissue	[O <sub>2</sub> ]state	[O <sub>2</sub> ]in	O <sub>2</sub> -gradient	Exchange
Lung	high	low	high pos	high prod
M1	low	high	high neg	high csmp
M2	low	high	high neg	high csmp

TABLE 8. Exchange Behaviors of the Parallel Crocodilian Topology

Tissue	[O <sub>2</sub> ]state	[O <sub>2</sub> ]in	O <sub>2</sub> -gradient	Exchange
Lung	high	low	high pos	high prod
M1	low	medium	low neg	low csmp
M2	low	medium	low neg	low csmp

In short, zero-order entity passing is quite simple due to the Diffusion Equilibrium Assumption (DEA). Each diffuser simply outputs its state concentration and uses the difference between its state and input concentrations as a diffusion gradient. Interestingly enough, real circulatory systems generally do attain equilibrium (relative to oxygen and carbon dioxide) between a tissue and its perfusing blood. In most cases, that equilibrium occurs about one-third of the way (from entry to exit) across each capillary (Guyton, 1986, pp. 493-496) - thus leaving considerable room for error. Hence, although

the DEA is an essential simplifying assumption for CIRC-SIM, it runs true to form in most circulatory systems.

### First-Order Information Passing

During zero-order simulation, CIRC-SIM focuses on two primary qualitative behaviors: the presence or absence of tissue blood flow (as depicted by the Directed Flow Network), and each tissue's input and state concentrations of various entities. Together, these give a reasonable sketch of a circulatory system's general operation under steady-state conditions. However, steady-state simulation and critique form the easier half of BIOTIC's bipartite analysis. In accounting for the effects of environmental perturbations and the regulatory adjustments that often follow them, CIRC-SIM must simulate and reason about changes in concentrations, resistances and flows.

As shown in Chapter III, dynamic analysis according to The Bipartite Teleology Model involves tissue exchange *tendencies* and the resistance and flow changes in response to those tendencies. In first-order simulation, CIRC-SIM derives those behaviors from the circulatory model by passing *influences* throughout the PC Topology. The whole process consists of five steps:

1. Activate the environment and task to determine exchange tendencies and activity levels.
2. Perform teleology-governed local resistance changes.
3. Propagate resistance changes throughout the GTH.
4. Determine net influences upon each characteristic flow.
5. Perform weighted qualitative constraint satisfaction to derive local qualitative flow changes that are globally consistent.

Since the analysis of influences plays a major role in each of these processes, I must describe influence analysis before moving on.

### Quantitative Influence Analysis

Once again, an influence is a relationship in which a change in one parameter exerts some sort of causal force to push another parameter up or down; and just like physical forces, influences can oppose and cancel one another. Hence, the presence of an influence does not guarantee the encouraged change. An *exogenous* or *external influence* is one that acts upon an *external parameter*; that is, one that cannot be influenced by the other parameters of the system. *Internal parameters*, on the other hand, can be affected by other system parameters. For instance, in CIRC-SIM, external parameters such as state concentrations and local/tissue resistances are immune to the effects of internal parameters such as blood flows and plasma

entity concentrations. Also, in CIRC-SIM, specific environments and tasks represent constant *external factors*, not parameters, since they lack the ability to change.

Due to the plethora of influences exerted by the environments and tasks that CIRC-SIM handles, and due to the ambiguity of resolving competing qualitative influences in all possible ways (Downing and Shrager, 1988), I have adopted a quantitative technique for influence propagation. Under this simple scheme, the influence of X upon Y is the quantitative product of the net influence upon X and the *sensitivity* of Y to X, where the sensitivity gives a rough estimate of the correlation between the two parameters. A positive sensitivity denotes a directly proportional relationship (i.e., changes in X push for the same directionality of change in Y), while a negative sensitivity signifies an inverse association (i.e., the change of X and its influence upon Y are of opposite signs). The magnitude of a sensitivity reflects the estimated strength of the association.

For convenience, I use the notation  $S(Y,X,n)$  to mean that Y is sensitive to X with degree or strength n. Also,  $\partial X[n]$  denotes that X has an influence of strength n. So, if  $\partial X[n1]$  and  $S(Y,X,n2)$ , then the influences upon Y include  $\partial Y[n1*n2]$ .

Sensitivities only exist between and among internal and external parameters, while CIRC-SIM models the effects of external factors (e.g., environments and tasks) upon external parameters as *primitive influences*. Sensitivities do not pertain to these relationships, since external factors cannot change. Hence, stored with each external factor is a list of the influences that it has upon various entity concentrations in various types of tissues. When that factor is activated, the influences are immediately attached to the appropriate exogenous parameter.

In most cases, CIRC-SIM uses the values +1 and -1 for sensitivities. For instance, if two tissues lie in series, then the resistances of each exert a +1 sensitivity upon the resistance of their serial tissue unit's (STU's) resistance. Similarly, a pump's flow output has a -1 sensitivity to the net downstream resistance, that is,  $S(\text{pump-output, resistance, -1})$ . However, tissues that participate in a parallel tissue unit (PTU) exert only a +1/2 sensitivity upon the PTU's resistance. I have based this assumption upon the simple fact that resistors in series have a significantly greater quantitative affect upon their aggregates than do parallel resistors.

To compute the net influence upon a parameter, CIRC-SIM simply adds up all of its influences. This brushes aside the ambiguities of qualitative perturbation analysis incurred by influence resolution - leaving flow envisionment as the only process in which CIRC-SIM actually manages the multiple possibilities of qualitative simulation. The next five sections illustrate the role of influence analysis during the five steps of first-order simulation.

### Environment and Task Activation

Each environment exerts primitive influences upon the state concentrations of certain entities in certain tissues. For instance, a "high altitude" environment exerts a -1 influence upon pulmonary oxygen.

Similarly, the task of "running" exerts a -1 influence upon the oxygen in leg muscles, and a +1 influence upon their carbon dioxide.

In addition, tasks exert influences upon the *activity levels* of tissues. To wit, the task of "swimming" imposes a +1 influence upon the activity levels of arm muscles (in humans), while the task of "hibernating" puts a -1 influence upon all tissues' activity levels. A tissue's resistance has a -1 sensitivity to its activity level. Hence, the immediate effect of, for instance, a net positive influence upon the activity level is an equal but opposite net influence upon the resistance. This resistance decrease should then encourage more perfusion.

For any entity X, a tissue K's exchange *tendency* for X is sensitive to both the activity level and  $[X]^{K\text{-state}}$ . In the case of the activity level, the sensitivity is always +1, but towards  $[X]^{K\text{-state}}$ , the sensitivity depends upon K's exchange mode: if K produces X, then the sensitivity is +1; if it consumes, -1.

To activate the environment and task of the critical context, CIRC-SIM simply caches their influences within the influence lists of the affected exogenous parameters. It then computes the net influences upon these parameters and then propagates those influences to the local resistances and exchange tendencies.

### Teleology-Based Resistance Changes

As shown in Table 3, different teleologies of BTM prefer different perfusion changes in response to tissue' exchange tendencies. In an effort to achieve these perfusion changes, teleologies exert influences upon resistances, but only in a very local manner. That is, for each tissue, CIRC-SIM simply indexes its tendency and the current teleology into Table 3. This returns a perfusion influence (all [+]s and [-]s in the table presumably have a magnitude of 1), which is then negated to form a resistance influence. However, if the tissue's activity level has already influenced its resistance, then the teleology's influence is withheld.

In essence, the activity level gets priority over the teleology in determining local resistance changes. This precedence confers with the general model of first-order criticism in BIOTIC: given a circulatory system that is in an environment and performing some task, evaluate its satisfaction of the teleology. The opposite precedence would mirror a different strategy: given a circulatory system in an environment and satisfying (as best it can) a teleology, see if it can perform some task.

At any rate, the influences upon resistance generated by activity levels and teleologies constitute acts of autoregulation. These are intended to alter the tissue's perfusion rate, but as mentioned in Chapter III, they have only local heuristic value. The influences upon all resistances and their relationships within the circulatory topology must all be taken into account in determining flow changes throughout the network. This global integration is the topic of the next two sections.



## Integrating GTH Resistance Changes

The primary role of the GTH is to transfer local resistance changes up through the aggregate tissue/resistance regions. Remember, each characteristic flow has one tissue hierarchy, which groups all of the tissues that the flow perfuses into nested parallel and serial regions. Each tissue hierarchy has one aggregate region at its highest level. The resistance change of that region determines the net influence upon the pump output of the characteristic flow. CIRC-SIM deals with each tissue hierarchy independently in determining these influences. Furthermore, as resistance influences ascend a tissue hierarchy, they affect the *distributors* of each parallel tissue aggregate (PTU) as well as the resistances of all the aggregates (PTUs and STUs). The following procedures (15 - 18) illustrate the computation of resistance influences throughout the GTH:

### PROCEDURE 15: PROPAGATE-GTH-RESISTANCE-INFLUENCES()

```
;; "res-infs" are resistance influences
∇ flow ∈ characteristic-flows(current-flow-interpretation)
    net-influence(pump-output(flow)) ←
        -1 * value(calc-res-infs(top(tissue-hierarchy(flow))))
```

PROCEDURE 16: CALC-RES-INFS (tagg) ;; tagg = a tissue aggregate = a ptu, stu or a single tissue

- 1) if type-of(tagg) = "ptu" or "stu"
  - then
    - res-infs(tagg) ←
      - ∇ kid-tagg ∈ children(tagg):
 collect calc-res-infs(kid-tagg)
- 2) if type-of(tagg) = "ptu" then update-ptu-distributors(tagg)
- 3) return list-of(tagg, calc-net-res-inf(tagg))

**PROCEDURE 17: CALC-NET-RES-INF (tagg)**

;; each influence has two parts: the tagg exerting it, and the  
;; numeric value of that influence.

- 1) net-res-inf(tagg)  $\Leftarrow$ 
  - case type-of(tagg):
    - a) "stu" or "tissue"
 
$$\sum \forall \text{ inf} \in \text{res-infs}(\text{tagg}): \text{value}(\text{inf})$$
    - b) "ptu"
 
$$[\sum \forall \text{ inf} \in \text{res-infs}(\text{tagg}): \text{value}(\text{inf})] / 2$$
- 2) return net-res-inf(tagg)

**PROCEDURE 18: UPDATE-PTU-DISTRIBUTORS (ptu)**

;; Each resistance influence exerts influences upon the flows down  
;; the two branches of a parallel region. The sensitivities are 1/2  
;; and -1/2 depending upon the orientation: the flow of a branch is  
;; indirectly proportional to the resistances of that branch, and  
;; direction proportional to those of the other branch.

- $\forall \text{ inf} \in \text{res-infs}(\text{ptu})$  do:
- 1) branch1  $\Leftarrow$  fetch-containing-branch(ptu, tagg(inf))
  - 2) branch2  $\Leftarrow$  fetch-other-branch(ptu, branch1)
  - 3) push( list-of(tagg(inf), -1 \* value(inf)/2),  
          flow-infs(branch1))
  - 4) push( list-of(tagg(inf), value(inf)/2),  
          flow-infs(branch2))

As shown, the results of propagating resistance influences are (a) the net influence upon the pump output of each flow, and (b) the flow influences down the branches of each PTU. CIRC-SIM communicates these influences to the relevant roles of the Role Network. To wit, distribution influences are passed from the PTUs of the GTH to their respective "splitter" roles, and pump-output influences of a flow are sent to the sender or splitter role of that flow's sending pump. This sets up the next stage of first-order simulation.

### Propagating Flow Influences Throughout the Role Network

The goal of this stage is to determine the qualitative influences upon the flow at each producer-consumer role (PCR) in the Role Network. To do so, CIRC-SIM simply goes through the "sender" and "splitter" roles of each pump (These roles signify the beginnings of a characteristic flow) and begins propagating the flow influences of that role along the flow's segment of the Role Network. During this propagation, only splitters and mixers modify the influences; all

other roles merely record the influences and pass them on. Procedures 19 - 21 sketch this process:

PROCEDURE 19: PROPAGATE-FLOW-INFLUENCES ( )

$\forall$  pump  $\in$  pumps:  
 $\forall$  pcr  $\in$  pcrs(pump):  
 if type-of(pcr) = "sender" or "splitter"  
 then pass-flow-infs(pcr, flow-infs(pcr))

PROCEDURE 20: PASS-FLOW-INFS (pcr, flow-infs)

1) Cache the flow-infs within pcr  
 2) case type-of(pcr)  
   a) "conduit", "tissue", "sender"  
     pass-flow-infs(role-network-child(pcr), flow-infs)  
   b) "receiver"  
     Halt  
   c) "splitter"  
      $\forall$  branch  $\in$  branches(pcr)  
       pass-flow-infs(pcr(branch),  
                                   append(flow-infs, flow-infs(branch)))  
   d) "mixer"  
     If both input arms have received flow-infs  
     then  
       a) out-infs  $\leftarrow$   
         prune-mixer-infs (append(flow-infs(arm1), flow-infs(arm2)))  
       b) If the mixing does not occur at a pump then  
         pass-flow-infs(role-network-child(pcr), out-infs)

PROCEDURE 21: PRUNE-MIXER-INFS (flow-infs)

Remove from flow-infs all influences that are either:

- a) duplicates
- b) members of the distributor influences of the splitter that matches up with this mixer (Once outside the parallel region, the internal distribution influences of that region are no longer valid.).

At the completion of Procedure 19, each PCR will have a complete list of flow influences; splitters and mixers will have influence lists for each arm. The quantitative net flow influence for each such location is just the sum of the

local influences. However, since each characteristic flow was treated independently during resistance propagation, the resulting net flow influences are not necessarily globally consistent. That is, regions that lie in series to one another may have different net flow values; in fact, they may be of opposite sign! Since the circulation cannot possibly sustain different flow changes to serial regions, these conflicting flow changes must be resolved. The succeeding section describes that resolution process.

### Resolving Flow Influences

Through flow-influence resolution, CIRC-SIM attains a globally consistent set of qualitative flow changes. To do so, CIRC-SIM uses the quantitative net flow influences from the previous step as weights during qualitative constraint satisfaction. This involves the following steps:

1. Generate confluences to represent flow conservation laws at all boundaries between different flows and at all branch points in the Role Network. Each confluence variable will denote the qualitative flow change of some location within some role; i.e., a *role location*.
2. Set the value of each confluence variable equal to the sign of the net flow influence at that variable's corresponding role location; and set the variable's weight equal to the magnitude of the net influence.
3. Perform weighted qualitative constraint satisfaction on the confluences.
4. Return the final qualitative values of each confluence variable to their respective role locations.

In weighted qualitative constraint satisfaction, a confluence variable's weight denotes its flexibility: a high weight means that the variable should not change, if at all possible, while a low weight hints of greater malleability. In the Role Network, locations with net flow influences of high magnitude should eventually receive a qualitative flow change equivalent to the sign of that quantitative net value. However, weaker flow influences in certain locations may be overridden by stronger influences elsewhere. For instance, if two regions lie in series and one has a +3 flow influence, while the other has a -1 influence; then weighted constraint satisfaction will probably return an increase of flow through both regions. The details of weighted constraint satisfaction lie beyond the scope of this thesis, but examples of its application appear in the next chapter.

## First-Order Simulation Summary

Looking back, the goal of first-order simulation is to mimic the reactions of a circulatory system to tissue exchange tendencies. Teleologies and activity levels determine the appropriate resistance changes, and the global integration of those changes across the PC topology results in modified flow rates. From the qualitative modeling perspective, a major problem with complex circulatory networks is the plethora of pumps and flows whose interactions must be captured in order to achieve a globally-consistent pattern of flow change. To handle this, CIRC-SIM resorts to quantitative influence analysis along each characteristic flow. The resulting net flow influences then serve as weights during qualitative constraint satisfaction, which produces a globally consistent pattern of qualitative flow change that reflects the quantitative strength of each local region's flow influences.

The final qualitative perfusion changes of each tissue may or may not satisfy the local demands of the teleology or activity level. The PC topology may enable or inhibit the simultaneous satisfaction of those requests. Hence, once CIRC-SIM outputs the final behaviors, BIOTIC's job remains only halfway completed, because to provide insightful analyses of circulatory systems, BIOTIC must highlight the relationships between global topology, exchange behavior and teleology. Thus begins the second half of BIOTIC's chore: criticism.

### Criticism in BIOTIC

The previous section detailed CIRC-SIM's derivation of globally-consistent local behaviors from a combination of local and global structure. Aside from certain resistance influences during regulatory simulation, CIRC-SIM runs free of the Bipartite Teleology Model's bias. Conversely, criticism demands that bias both as an evaluation standard and as a schema for explanation. Whereas Chapter III spelled out the biases of BTM, this section runs through the procedures used by BIOTIC to operationalize those biases in criticizing the outputs of CIRC-SIM.

In BIOTIC, criticism consists of two stages. The first, *evaluation*, employs BTM to interpret exchange behaviors relative to the critical teleology. In *explanation*, the second stage, BIOTIC uses behaviors and the teleological bias to identify key properties of the PC Topology that justify the behaviors. The net result is a critique that describes how circulatory topologies contribute, via exchange behaviors, to circulatory teleologies.

### Evaluation: The First Half of Criticism

Evaluation is fairly straightforward. Given a teleology and a qualitative behavior, BIOTIC merely compares the behavior to the teleology's recommended behavior and assigns an evaluation between -1 and 1 depending upon the difference, where a 1 denotes qualitative equality and a -1 implies that the values are at opposite ends of the quantity space. For instance, assume the five-

point quantity space of diffusion gradients: *high negative, low negative, zero, low positive, and high positive*. Now, a comparison of a *high positive* gradient to *high negative* one yields a -1 local evaluation, since the values occupy opposite ends of the quantity space. Conversely, a *low positive* compared to a *low positive* merits a perfect evaluation (i.e., 1), while *zero* versus *high positive* merits a 0. Once all local evaluations have been computed, BIOTIC simply averages them to derive the global evaluation.

In zero-order evaluation, BIOTIC compares binary flows and qualitative gradients to the recommendations of Table 2 in determining the rating for each diffusion instance (or lack thereof). On the other hand, first-order evaluation compares the qualitative flow changes computed by CIRC-SIM to those prescribed by Table 3. During first-order evaluation, BIOTIC assumes that perfusion changes have a significantly greater impact upon exchange rates than do changes in the incoming concentrations. This coincides with the physiological literature (Burggren, 1987; Guyton, 1986), which accentuates the importance of perfusion changes during periods of exchange modification. CIRC-SIM does compute changes in incoming concentrations, but BIOTIC ignores them in the attempt to more closely mirror the critiques of physiologists.

The final result of evaluation is a tabular listing of the actual and desired behaviors at each exchange site or potential exchange site (in the case of no perfusion). Those tissues that lie along multiple arcs of the DFN will receive one evaluation per diffusion instance, since the incoming concentrations and perfusion changes may vary with the arc/flow. The next chapter provides many examples of these evaluation tables, e.g., Table 9.

#### Explanation: The Second Half of Criticism

As discussed above, evaluations connect teleologies to circulatory behaviors, so to complete our desired chain from teleology to topology, we must next connect the behaviors to the global circulatory structure. In BIOTIC, this constitutes *explanation*.

This is the crucial step in conveying the relationships between the function and topological form of circulatory systems. These relationships provide the grounds for comparing BIOTIC's critiques to those of physiologists.

In zero-order explanation, BIOTIC searches the *feed* lists of each diffuser for the teleology-recommended relationships of Table 4 and bases its explanation upon the presence or absence of those *communication* paths. Thus, teleology biases zero-order explanation by supplying a schema for behavioral interpretation.

During first-order explanation, BIOTIC focuses on those tissues whose exchange *tendencies* merit teleology-advocated flow changes (as presented in Table 3), or whose activity levels demand flow changes. It then attempts to parse the actual flow changes to those tissues into a concise and comprehensive story of how *flowpath* relationships affect those changes. In addition, BIOTIC compares the tendencies of various producers and consumers and then uses that comparison along with the teleology as an index into Table 5, which houses recommended flowpath relations for dynamic purposefulness. Those

recommendations and their statuses (i.e., either "satisfied", "partially satisfied" or "violated") also appear in the first-order explanation.

### Zero-Order Explanation

Zero-Order explanation emphasizes the communication relationships between diffusers throughout the Role Network. In static explanation mode, BIOTIC focuses on each diffuser's feed list, which it classifies and then compares to a schema embodying the teleology's communication recommendation. These schemas are known as "TCR"s.

There are three important criteria for feed-list classification and TCR comparison:

1. Type - For each signal, does it come from a producer or consumer?
2. Purity - Do all of the signals come from the same type of site (i.e., producer or consumer)?
3. Feedback - Does the diffuser signal itself?

These were introduced in Chapter III.

Each of the four teleologies has a TCR indicating its preferred communication relationships, which appear in Table 4. Each TCR consists of one or more priority levels, within which reside recommendations. Each recommendation has three fields: filter, test and evaluator. The filter determines the type of diffuser that the recommendation applies to. The test is a predicate that the diffuser should satisfy (if it passes the filter). Finally, the evaluator is either universal or existential. The former implies that for the Role Network to satisfy the recommendation, no diffuser that passes the filter can fail the test. However, if no diffuser's pass the filter, the recommendation is vacuously satisfied. Conversely, to satisfy the existential evaluator, an RN must have at least one diffuser that passes the filter and test, and no diffusers that pass the filter but fail the test. Hence, during zero-order criticism, BIOTIC evaluates both the exchange-site behavior and the communication topology, although in this latter case, the evaluation is more of a sidelight to the explanation. The four TCRs appear in Schemas 1 - 4.

**SCHEMA 1: Transport TCR****Priority level 1:****Recommendation 1a:****filter: producer****test: pure-c-feed****evaluator: existential****Recommendation 1b:****filter: consumer****test: pure-p-feed****evaluator: existential****Priority level 2:****Recommendation 2a:****filter: producer-or-consumer****test: no-feedback****evaluator: universal****SCHEMA 2: Conserve TCR****Priority level 1:****Recommendation 1a:****filter: producer****test: no-consumer-feed****evaluator: universal****Recommendation 1b:****filter: consumer****test: no-producer-feed****evaluator: universal**



**SCHEMA 3: Dissipate TCR****Priority level 1:****Recommendation 1a:**

filter: producer  
 test: no-feedback  
 evaluator: universal

**Recommendation 1b:**

filter: consumer  
 test: feedback  
 evaluator: existential

**Priority level 2:****Recommendation 2a:**

filter: producer  
 test: pure-c-feed  
 evaluator: universal

**Recommendation 2b:**

filter: consumer  
 test: pure-c-or-mixed-feed  
 evaluator: existential

**SCHEMA 4: Accumulate TCR****Priority level 1:****Recommendation 1a:**

filter: producer  
 test: feedback  
 evaluator: existential

**Recommendation 1b:**

filter: consumer  
 test: no-feedback  
 evaluator: universal

**Priority level 2:****Recommendation 2a:**

filter: producer  
 test: pure-p-or-mixed-feed  
 evaluator: existential

**Recommendation 2b:**

filter: consumer  
 test: pure-p-feed  
 evaluator: universal

The TCRs make zero-order explanation quite simple. BIOTIC fetches the current teleology's TCR and then evaluates the Role Network relative to each of the TCR's recommendations. BIOTIC then outputs the recommendations (ranked by priority), their evaluations, and the diffusers that contribute to its satisfaction or violation. Furthermore, BIOTIC elaborates each of those diffusers by pointing out their feed signals that hold relevance for the teleology. For instance, if a producer, P, was supposed to have a pure-c feed but did not, then BIOTIC would output the "violating" producer that signalled P. It

also indicates the flows through which the signal was sent. Complete examples appear in the next chapter.

In sum, BIOTIC employs the teleological bias in the form of TCRs to structure and focus the static explanation of circulatory behavior. These explanations highlight the communication relationships (or lack thereof) prescribed by the teleology and thereby link topology to teleology in steady-state analysis.

### First-Order Explanation

First-order explanation consists of a causal and a structural justification of perfusion changes. In the former, BIOTIC presents an organized causal trace of parameter changes and their influences, while the latter involves *flowpath* relationships that enable or inhibit the mutual satisfaction of tissue flow demands. These relations illustrate the role of topology in the regulatory success or failure of a circulatory system.

In causal tracing, BIOTIC simply follows the influence chains that CIRC-SIM saves during regulatory simulation. It then organizes these interactions into a few classes:

1. Local resistance influences - activity-level and teleological influences upon tissue resistance.
2. Serial tissue unit influences - effects of subordinate resistances upon the resistance of their STU.
3. Parallel tissue unit influences - effects of subordinate resistances upon the resistance and flow distributors of their PTUs.
4. Pump-output influences - effects of the tissue hierarchy's net resistance influence upon the pump output of a characteristic flow.
5. Perfusion influences - the combination of pump-output and flow-distributor influences that affect a diffuser's perfusion rate.

Unfortunately, the current implementation of the weighted constraint satisfier does not cache the justifications of variable changes, nor does it necessarily propagate change in any "causal" manner, so BIOTIC lacks an account of the interactions between the desired flow changes of different characteristic flows. Thus, BIOTIC's causal explanations only capture the independent behaviors of each characteristic flow. As future work, I hope to enhance the constraint satisfier so as to supply a complete behavioral trace of regulatory simulation.

However, the structural phase of regulatory explanation ignores all of the local interactions and focuses on the final globally-consistent perfusion changes; it then justifies them in terms of the flowpath relationships between

various regions. To do so, BIOTIC alternates between highlighting interesting relationships between diffusers and grouping diffusers with common flow properties into regions, which help reduce the redundancy of BIOTIC's explanations.

Structural justification involves two modes: behavioral and teleological. In behavioral mode, BIOTIC focuses on the resistance changes and perfusion changes of each diffuser/site. Since the inverse of a resistance change denotes the "desired flow" of a tissue (regardless of whether the activity level or teleology influenced that desire), behavioral mode actually focuses on the relationship between the desired and actual perfusion change of each site. BIOTIC then explains these topologically.

In behavioral mode, BIOTIC judges the "interestingness" of a relationship between two *groups* (i.e., a site or a region of sites) according to (a) their flow properties (i.e., desired and actual flow change), and (b) their flowpath relationship within the GTH. The rules of Figure 14 summarize the interesting relationships that BIOTIC recognizes between any two site groups, G1 and G2.

The first four rules of Figure 14 pertain to serial relationships. Rules 1 and 3 reflect that fact that when two groups lie in *absolute series* (i.e., the same medium molecules flow through each), their perfusion changes must be equivalent. However, when the relationship weakens to *non-absolute series* (i.e., in moving between the two groups, the flowing medium splits more times than it mixes with itself) it may help satisfy common flow demands, but it holds no guarantees. Thus, rules 2 and 4 point out weak, but still interesting relationships. Finally, Rule 5 highlights cases in which parallel relationships (whether direct or indirect) enable the fulfillment of different flow demands. In the teleological mode of structural justification, BIOTIC looks at the exchange tendencies and actual perfusion changes of site groups. It then uses the teleology-based topological recommendations of Table 5 as a bias for analyzing the actual flowpath relationships between production and consumption groups. Table 5 has simple topological recommendations: either absolute-serial or parallel. When a producer group and consumer group have tendencies that yield a non-nil result from Table 5, BIOTIC recognizes the groups as interesting. It then highlights their flowpath relationship and compares it to the table's recommendation. This comparison yields an evaluation according to the conditional of Figure 15. In this way, BIOTIC accentuates the producer-consumer flowpath relationships of teleological relevance.

In review of regulatory explanation, BIOTIC first organizes influences into a causal description of how local resistance changes affect aggregate resistances, flow distributions, pump outputs, and finally, local perfusion rates. Next, BIOTIC pinpoints the salient flowpath relationships contributing to perfusion behavior and teleological satisfaction or violation. These relationships embody a fundamental goal of this research by connecting global structure to behavior and teleology.

**Rule 1:**

desired-flow-change(G1) = desired-flow-change(G2)  
 actual-flow-change(G1) = actual-flow-change(G2)  
 flowpath-rel(G1,G2) = "serial" and "absolute"  
 ==> "Absolute serial relation enables satisfaction of common  
 flow demands"

**Rule 2:**

desired-flow-change(G1) = desired-flow-change(G2)  
 actual-flow-change(G1) = actual-flow-change(G2)  
 flowpath-rel(G1,G2) = "serial" and "non-absolute"  
 ==> "Serial relation helps satisfy common flow demands"

**Rule 3:**

desired-flow-change(G1)  $\neq$  desired-flow-change(G2)  
 actual-flow-change(G1) = actual-flow-change(G2)  
 flowpath-rel(G1,G2) = "serial" and "absolute"  
 ==> "Absolute serial relation precludes satisfaction of disparate  
 flow demands"

**Rule 4:**

desired-flow-change(G1)  $\neq$  desired-flow-change(G2)  
 actual-flow-change(G1) = actual-flow-change(G2)  
 flowpath-rel(G1,G2) = "serial" and "non-absolute"  
 ==> "Serial relation deters the satisfaction of disparate flow demands"

**Rule 5:**

desired-flow-change(G1)  $\neq$  desired-flow-change(G2)  
 actual-flow-change(G1) = desired-flow-change(G1)  
 actual-flow-change(G2) = desired-flow-change(G2)  
 flowpath-rel(G1,G2) = "parallel"  
 ==> "Parallelism enables mutual satisfaction of disparate flow demands"

FIGURE 14. Interestingness rules for dynamic explanation.

- 1)  $\text{actual-rel}(G1,G2) = \text{recommended-rel}(G1,G2)$   
 $\implies$  evaluation = "satisfied"
- 2)  $\text{actual-rel}(G1,G2) = \text{"non-absolute series"}$  and  
 $\text{recommended-rel}(G1,G2) = \text{"absolute series"}$  or "parallel"  
 $\implies$  evaluation = "partially satisfied"
- 3) otherwise  
 $\implies$  evaluation = "violated"

FIGURE 15. Teleology-based flowpath-relation evaluation.

### Summary

BIOTIC performs two general operations upon producer-consumer networks: qualitative simulation and criticism. BIOTIC's simulator, CIRC-SIM, uses pump contraction histories to envision all possible flow topologies, each of which determines a unique producer-consumer behavior of the network. CIRC-SIM then temporally and spatially abstracts each pulsatile flow topology into a Producer-Consumer (PC) Topology, which serves as the backbone for both steady-state and regulatory analysis. Specifically, CIRC-SIM propagates entity concentrations along with changes in entity concentrations, resistances, and flows throughout the PC Topology.

Criticism consists of two stages: evaluation and explanation. The former compares teleological recommendations to the actual exchange behaviors of tissues/sites, while the latter justifies those behaviors in terms of the global circulatory structure. All told, criticism integrates structure, behavior and teleology to create comprehensive descriptions of circulatory systems.

This chapter has discussed the basic algorithms employed by BIOTIC during simulation and criticism. The next chapter illustrates the use of those procedures in the analysis of the reptilean and mammalian circulatory systems.

## CHAPTER V

### BIOTIC IN ACTION

This chapter describes the behavior of BIOTIC when applied to a variety of circulatory models and critical contexts. In particular, abstract models of the reptilian and mammalian circulatory systems are simulated and critiqued from both the steady-state and regulatory perspective.

The first section illustrates static analysis. It begins by considering the basic component topologies of each system. Next, flow envisionment and pulsatile abstraction yield PC Topologies for the circulations. After that, entities are propagated through each PC Topology to yield exchange behaviors, which provide the grist for evaluation. This section concludes with explanations for each PC Topology relative to all four teleologies.

The second section illustrates regulatory analysis. In this mode, environmental factors instigate tissue exchange tendencies. BIOTIC then simulates autoregulation by altering local resistances. Next, the PC Topologies are used to propagate resistance and flow changes throughout the circulation. Finally, the resulting perfusion changes in combination with the teleology support first-order criticism. The evaluations and explanations composing these criticisms are presented in detail.

#### Static Analysis of the Reptilian and Mammalian Circulations

As shown in Figures 16 and 17, the reptilian and mammalian circulatory models consist of four tissues and an assortment of pumps, vessels and valves. The reptilian model has a single ventricle, while the mammalian version has two. As we shall see, the structural differences between the two models promote vastly different exchange behaviors.

#### Static Analysis of the Reptile

Starting with the reptile, CIRC-SIM receives the model of Figure 16 along with the following pumping history (C = "contracted"; R = "relaxed"):

```
Vent: ((C 1 2) (R 3 4) (C 5 6) (R 7 8) (C 9 10) (R 11 12))
Vein1: ((R 1 2) (C 3 4) (R 5 6) (C 7 8) (R 9 10) (C 11 12))
Vein2: ((R 1 2) (C 3 4) (R 5 6) (C 7 8) (R 9 10) (C 11 12))
```

Also, CIRC-SIM receives the initial pump amounts:

Vent: Full, Vein1: Empty, Vein2: Empty

Finally, CIRC-SIM inputs one or more critical contexts and the appropriate state concentrations. For this example, assume that it receives four zero-order contexts: oxygen transport, oxygen conservation, oxygen dissipation and oxygen accumulation. Hence, the prerequisite tissue state concentrations involve oxygen:

Lung1: High, Lung2: High, M1: Low, M2: Low

CIRC-SIM then performs flow envisionment. Given the pumping histories and the structural constraints, the only source of ambiguity is the relationship between the contractile pressures of Vein1 and Vein2. This leads to three possible flow topologies depending upon the Vein1-Vein2 pressure relationship:

1. Pressure(Vein1)  $\ll$  Pressure(Vein2): blood circulates only through the systemic (i.e., muscle) region, since Vein2 overpowers Vein1 and blocks flow throughout the pulmonary (i.e., lung) region.
2. Pressure(Vein1)  $\approx$  Pressure(Vein2): blood circulates to the pulmonary and systemic regions.
3. Pressure(Vein2)  $\ll$  Pressure(Vein1): blood circulates only to the pulmonary region.

Let us call these the *systemic*, *complete* and *pulmonary* topologies, respectively. On each of the three, CIRC-SIM performs cycle detection and flow merging to yield the Directed Flow Networks (DFNs) of Figures 18 - 20. CIRC-SIM then assigns roles to the components of each DFN to produce three Role Networks (see Appendix A). Furthermore, it spatially aggregates the characteristic flows to form three Global Tissue Hierarchies (GTHs), which also appear in Appendix A. Together, the RN and GTH of each flow topology constitute a PC Topology. CIRC-SIM then uses the RN to propagate oxygen concentrations. The blood oxygen concentrations appear in Figures 18 - 20, while Tables 9 - 11 contain the exchange behaviors for each topology, along with the evaluation of each topology relative to all four teleologies. I will now discuss each of the three situations.

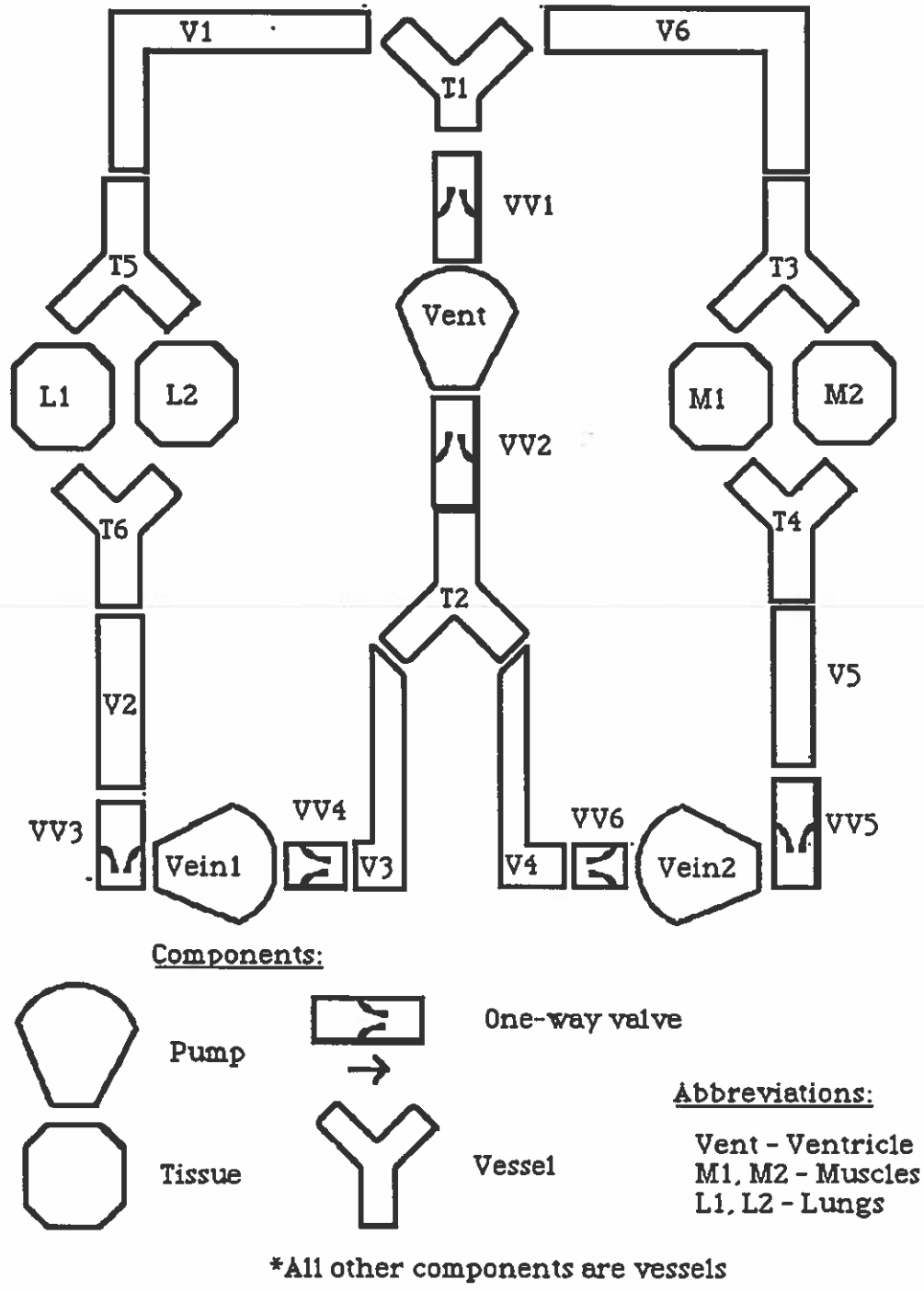

FIGURE 16. Reptilian circulatory model.



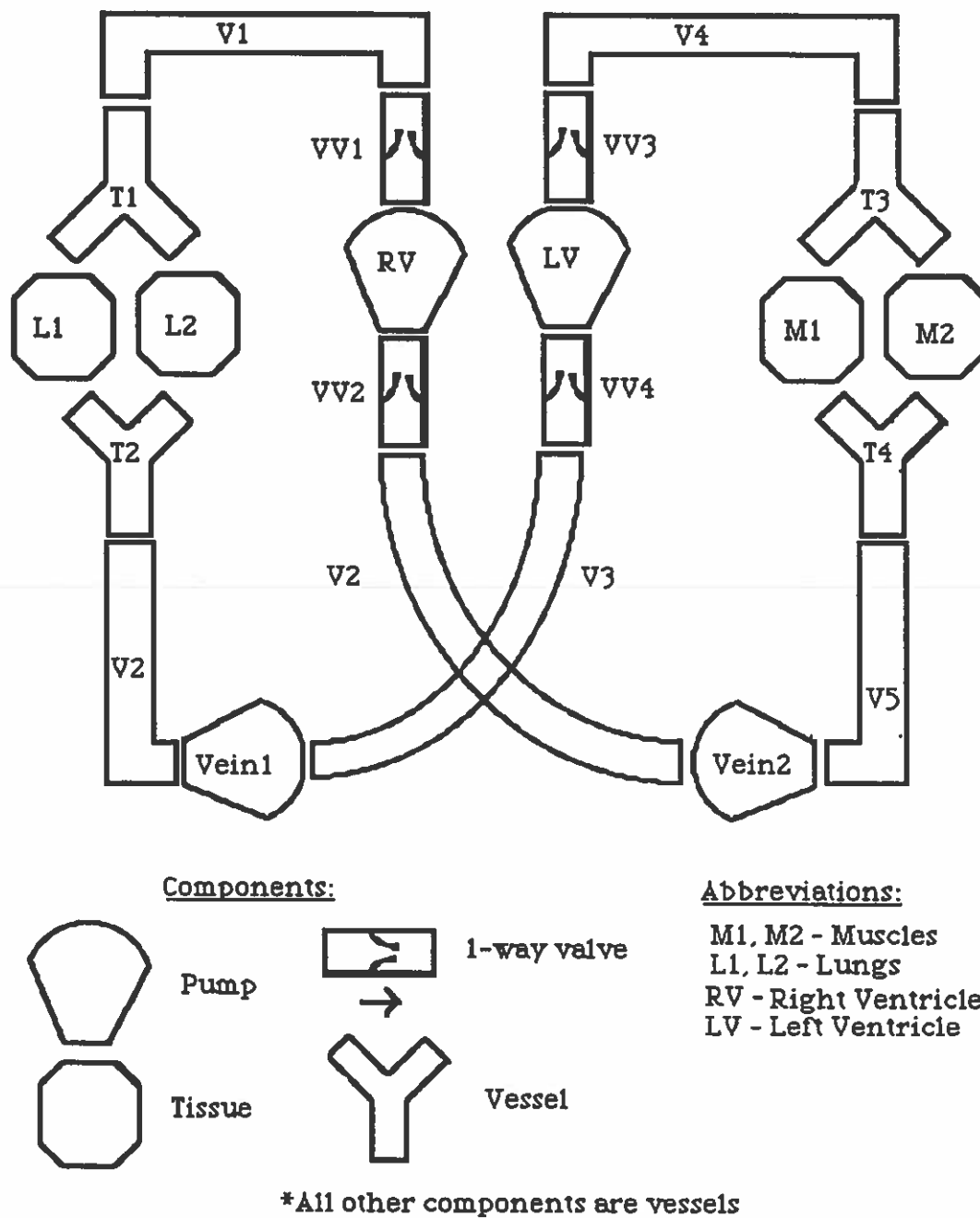

FIGURE 17. Mammalian circulatory model.

The systemic topology (see Table 9 and Figure 18) exhibits no exchange, since, for each muscle,  $[O_2]^{out}$  feeds back to become  $[O_2]^{in}$ . This lack of exchange merits a high evaluation relative to the conservation teleology; and since the oxygen consumers have zero gradients, while the producers have no flow, this earns a perfect dissipative rating. However, transport and accumulation give very poor evaluations to the systemic topology. All of these ratings follow from the recommendations of Table 2.

TABLE 9. Systemic Reptilian Topology Exchange Behaviors and Evaluations

Comp	[O <sub>2</sub> ]-in	[O <sub>2</sub> ]-st	Grad	Exchg	Trans	Cons	Diss	Accum
L1	nil	High	nil	nil	-1	1	1	-1
L2	nil	High	nil	nil	-1	1	1	-1
M1	Low	Low	Zero	Zero	0.5	0	1	-0.5
M2	Low	Low	Zero	Zero	0.5	0	1	-0.5
Global Evals:					-0.25	0.5	1.0	-0.75

\*A value of "nil" implies that the component receives no flow.

In the complete topology (see Table 10 and Figure 19), all tissues receive flow, and the systemic and pulmonary flows mix at T2. This creates a "medium" oxygen concentration as the input to each tissue. Hence, all exchange rates are low. Still, the presence of exchange at each tissue garners a low conservation rating but a relatively high transport rating. Accumulation and dissipation are supported by the low gradients, but not to any high degree, as their 0.25 ratings attest.

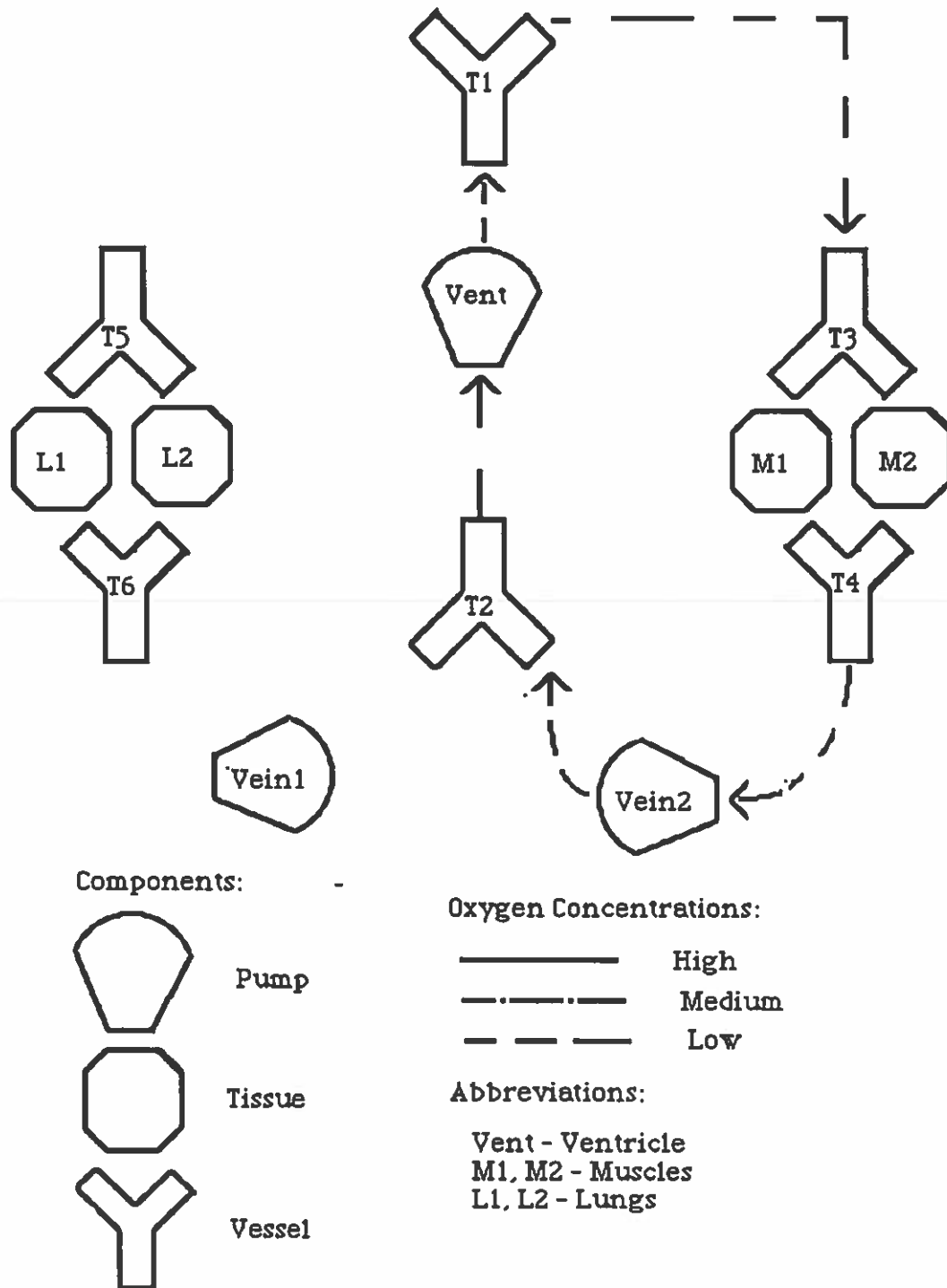

FIGURE 18. Systemic reptilian DFN.

TABLE 10. Complete Reptilian Topology Exchange Behaviors and Evaluations

Comp	[O2]-in	[O2]-st	Grad	Exchg	Trans	Cons	Diss	Accum
L1	Medium	High	Low Pos	Low Prod	0.75	-0.5	-0.25	0.75
L2	Medium	High	Low Pos	Low Prod	0.75	-0.5	-0.25	0.75
M1	Medium	Low	Low Neg	Low Consm	0.75	-0.5	0.75	-0.25
M2	Medium	Low	Low Neg	Low Consm	0.75	-0.5	0.75	-0.25
Global Evals:					0.75	-0.5	0.25	0.25

The pulmonary topology (see Table 11 and Figure 20) represents the converse of the systemic topology. Whereas the latter involved only consumers, the former perfuses only producers. Hence, in the pulmonary topology, static accumulation is perfect, while dissipation is dismal; and, just as in the systemic topology, conservation rates high, but transport scores low.

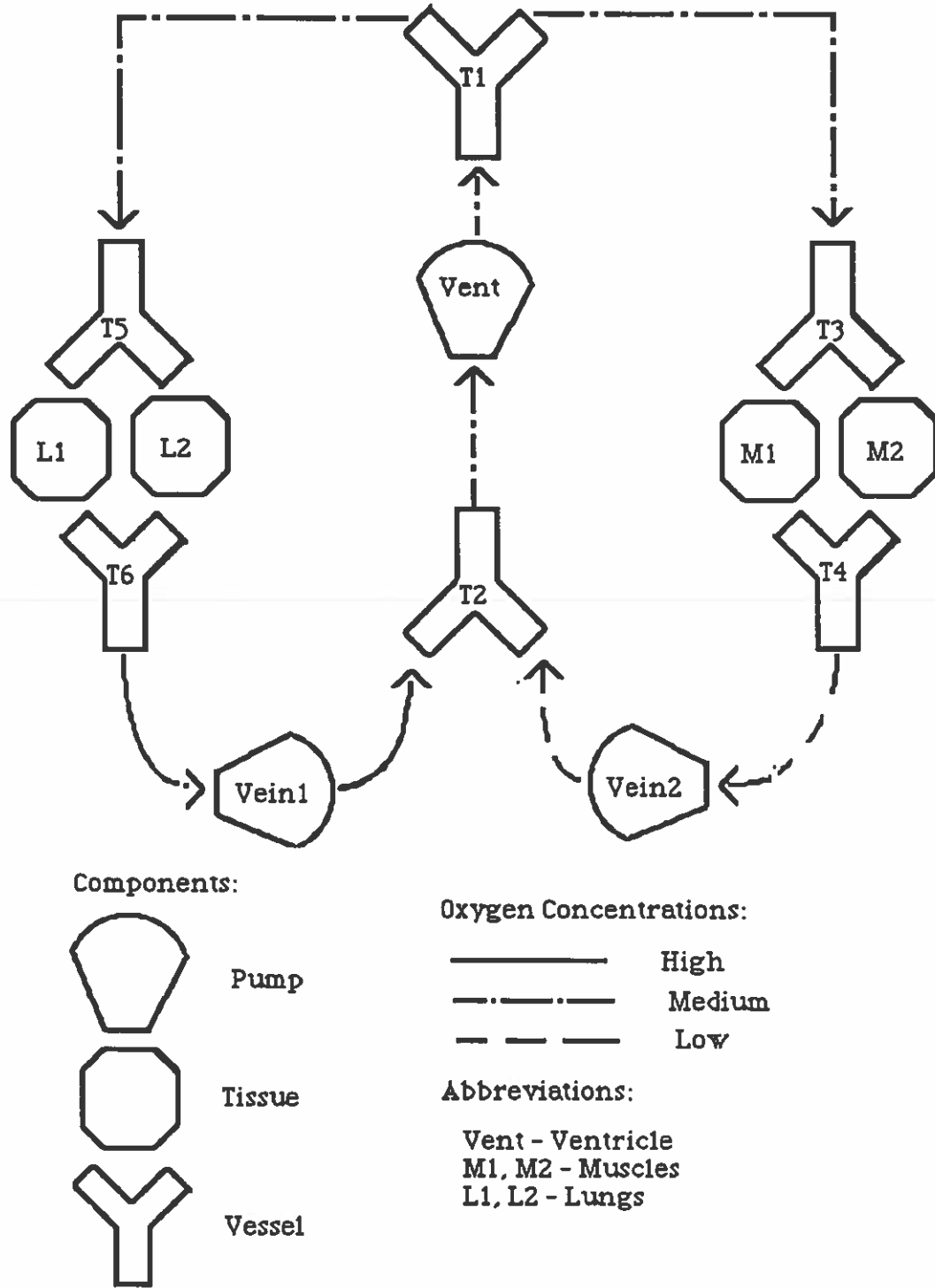

FIGURE 19. Complete reptilian DFN.

TABLE 11. Pulmonary Reptilian Topology' Exchange Behaviors and Evaluations

Comp	[O <sub>2</sub> ]-in	[O <sub>2</sub> ]-st	Grad	Exchg	Trans	Cons	Diss	Accum
L1	High	High	Zero	Zero	0.5	0	-0.5	1
L2	High	High	Zero	Zero	0.5	0	-0.5	1
M1	nil	Low	nil	nil	-1	1	-1	1
M2	nil	Low	nil	nil	-1	1	-1	1
Global Evals:					-0.25	.5	-0.75	1.0

\*A value of "nil" implies that the component receives no flow.

After evaluating a topology, BIOTIC employs the teleology's communication recommendations (TCRs) from Chapter IV to bias the explanation. For example, to explain the complete topology relative to oxygen transport, BIOTIC fetches the transport TCR and compares its recommendations to the feeder lists of each tissue. This leads to the automatically-generated explanation of Figure 21.

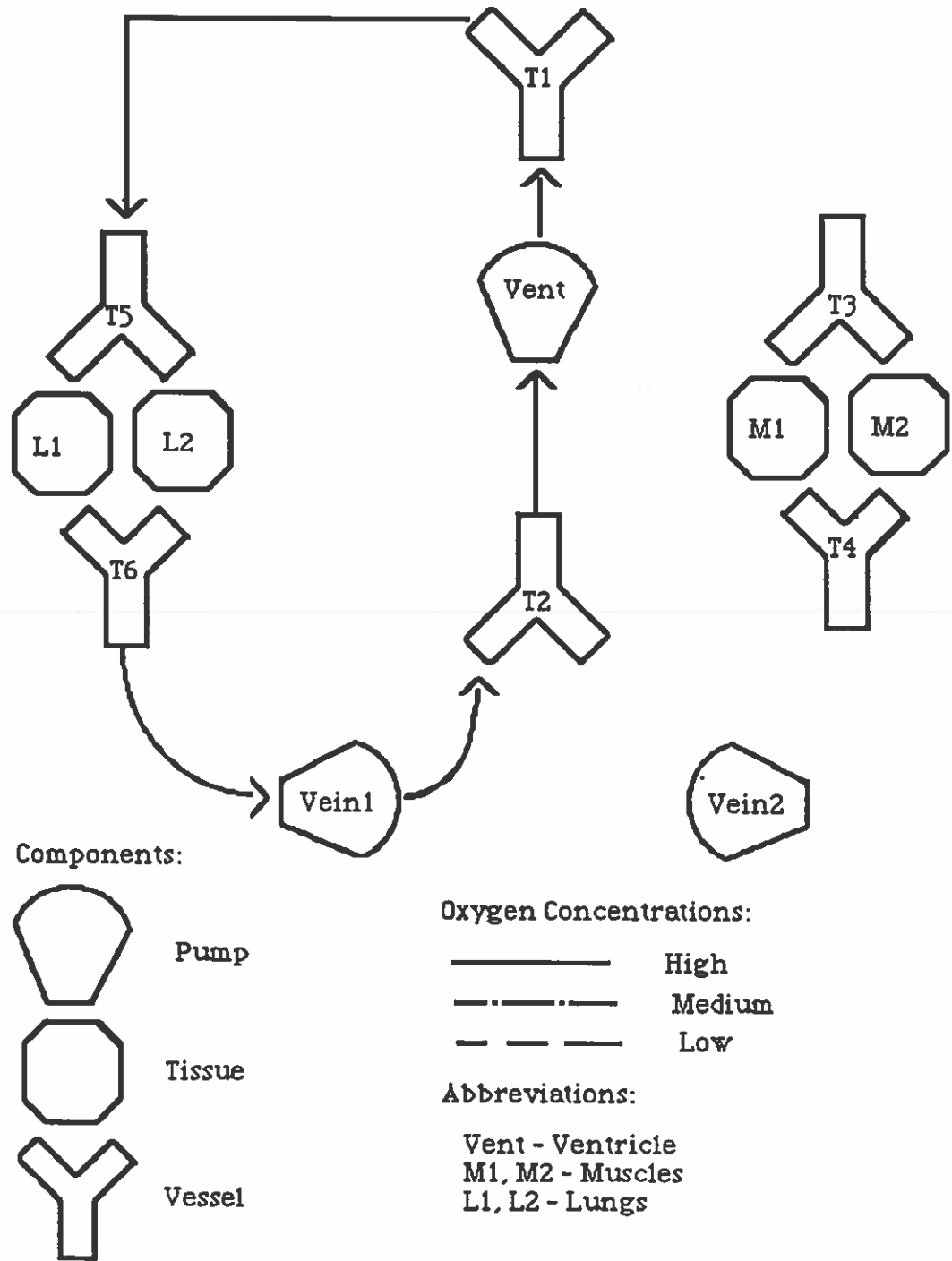

FIGURE 20. Pulmonary reptilian DFN.

Priority Level 1:

Oxygen Transport recommends that producers have pure consumer feed.

Evaluation: Violated

Satisfiers: nil

Violators:

Lung1 - which is fed by Lung1 and Lung2 (both producers)

Lung2 - which is fed by Lung1 and Lung2 (both producers)

Oxygen Transport recommends that consumers have pure producer feed.

Evaluation: Violated

Satisfiers: nil

Violators:

M1 - fed by M1 and M2 (both consumers)

M2 - fed by M1 and M2 (both consumers)

Priority Level 2:

Oxygen Transport recommends that producers and consumers have no feedback.

Evaluation: Violated

Satisfiers: nil

Violators:

Lung1, Lung2, M1, M2 - All feed back on themselves.

FIGURE 21. Static explanation of reptilian complete topology relative to the oxygen-transport teleology.

Similarly, to explain the same topology relative to oxygen dissipation, BIOTIC retrieves the dissipation TCR and uses it to synthesize the quite different explanation of Figure 22.

In the explanations of Figures 21 and 22, note that BIOTIC biases the analyses in terms of the teleological recommendations. It then outputs the tissues whose feed lists satisfy or violate each recommendation. Furthermore, it presents only the relevant aspects of each feed list. For instance, in the first recommendation of the first explanation, since Lung1 and Lung2 violate the



**Priority Level 1:**

Oxygen Dissipation recommends that producers have no feedback.

Evaluation: Violated

Satisfiers: nil

Violators:

Lung1, Lung2 - both exhibit feedback.

Oxygen Dissipation recommends that consumers have feedback.

Evaluation: Satisfied

Satisfiers:

M1, M2 - both exhibit feedback

Violators: nil

**Priority Level 2:**

Oxygen Dissipation recommends that producers  
have pure consumer feed.

Evaluation: Violated

Satisfiers: nil

Violators:

Lung1 - fed by Lung1 and Lung2 (both producers)

Lung2 - fed by Lung1 and Lung2 (both producers)

Oxygen Dissipation recommends that consumers  
have pure-consumer or mixed feed.

Evaluation: Satisfied

Satisfiers:

M1 - has mixed feed from M1, M2 (consumers) and L1, L2  
(producers)

M2 - has mixed feed from M1, M2 (consumers) and L1, L2  
(producers)

Violators: nil

**FIGURE 22.** Static explanation of reptilian complete topology  
relative to the oxygen-dissipation teleology.

pure-consumer-feed constraint, BIOTIC only displays those feeders of Lung1 and Lung2 that lead to the violation (i.e., Lung1 and Lung2, the producers).

Table 12 provides a complete summary of the four explanations for each of the three reptilian topologies. Each simplified explanation describes only the level-one priority items from the appropriate TCR:

TABLE 12. Telcology-Based Explanations of Reptilian Topologies

<u>Topology</u>	<u>Transport</u>	<u>Conserve</u>	<u>Dissipate</u>	<u>Accumulate</u>
Systemic	No flow to P's -> Violate Pure-c feed to C's -> Violate	No Flow to P's -> Satisfy Pure-c feed to C's -> Satisfy	Feedback to C's -> Satisfy No feedback to P's -> Satisfy	Feedback to C's -> Violate No feedback to P's -> Violate
Complete	Mixed Feed at P's and C's -> Violate	Flow to P's and C's -> Violate Not pure-c feed to C's, nor pure-p feed to P's -> Violate	Feedback to C's -> Satisfy Feedback to P's -> Violate	Feedback to C's -> Violate Feedback to P's -> Satisfy
Pulmonary	No flow to C's -> Violate Pure-p feed to P's -> Violate	No Flow to C's -> Satisfy Pure-p feed to P's -> Satisfy	Feedback to P's -> Violate No feedback to C's -> Violate	Feedback to P's -> Satisfy No feedback to C's -> Satisfy

To summarize Table 12, the systemic topology fails as an oxygen transport system since it lacks blood flow to its (oxygen) producers; but oxygen conservation, the dual of transport, is satisfied. However, the exclusive flow to consumers insures that consumers feed back on themselves. This merits a favorable dissipation explanation and an unfavorable accumulation explanation.

Due to the mixing of oxygenated and deoxygenated blood at T1, the complete topology has mixed feeds at both producers and consumers. This violates oxygen transport since exchange gradients are not high; it also violates conservation, since diffusion still occurs. In the case of oxygen dissipation, the recommended feedback to consumers is offset by feedback to producers. Conversely, for oxygen accumulation, the recommended producer feedback is counterbalanced by the consumer feedback.

The pulmonary topology lacks consumer flow and therefore violates the communication-relationship expectations of oxygen transport; but this helps satisfy conservation. Oxygen accumulation is enhanced by the combination of producer feedback and no consumer feedback; but this combination violates oxygen dissipation.

#### Static Analysis of the Mammal

Now consider the mammalian circulation, for which CIRC-SIM receives the component topology of Figure 17 along with the following pumping history:

RV: (C 1 2) (R 3 4) (C 5 6) (R 7 8) (C 9 10) (R 11 12)  
 LV: (C 1 2) (R 3 4) (C 5 6) (R 7 8) (C 9 10) (R 11 12)  
 Vein1: (R 1 2) (C 3 4) (R 5 6) (C 7 8) (R 9 10) (C 11 12)  
 Vein2: (R 1 2) (C 3 4) (R 5 6) (C 7 8) (R 9 10) (C 11 12)

and pump amounts:

RV - full, LV - full, Vein1 - empty, Vein2 - empty.

The oxygen state concentrations are identical to those of the reptile, and again, assume the same four static teleologies.

In this case, flow envisionment finds no sources of ambiguity and therefore produces a single flow interpretation, which gives rise to the DFN of Figure 23, an RN, and a GTH (both described in Appendix A). CIRC-SIM then propagates oxygen throughout the RN to yield the oxygen concentrations of Figure 23 and the exchange behaviors of Table 13. Evaluation then generates the ratings that also appear in Table 13. Note that the mammalian topology receives a perfect transport evaluation and a poor conservation score (since the two teleologies oppose one another), while the dissipation and accumulation ratings are relatively neutral (i.e., close to zero).

As a sample explanation, Figure 24 captures the communication relationships in the mammalian flow topology that hold relevance for the oxygen-transport teleology. Basically, the mammal exemplifies zero-order oxygen-transport excellence due to the high exchange gradients at each tissue. BIOTIC recognizes this and explains it in terms of the pure communication relationships between producers and consumers. As for the other three oxygen teleologies, summaries of their explanations appear in Table 14. In short, conservation is violated by the flow to both producers and consumers. Dissipation and accumulation are violated due to the lack of feedback to consumers and producers, respectively.

TABLE 13. Mammalian Topology Exchange Behaviors and Evaluations

Comp	[O2]-in	[O2]-st	Grad	Exchg	Trans	Cons	Diss	Accum
L1	Low	High	High Pos	High Prod	1	-1	0	0.5
L2	Low	High	High Pos	High Prod	1	-1	0	0.5
M1	High	Low	High Neg	High Consm	1	-1	0.5	0
M2	High	Low	High Neg	High Consm	1	-1	0.5	0
Global Evals:					1.0	-1.0	0.25	0.25

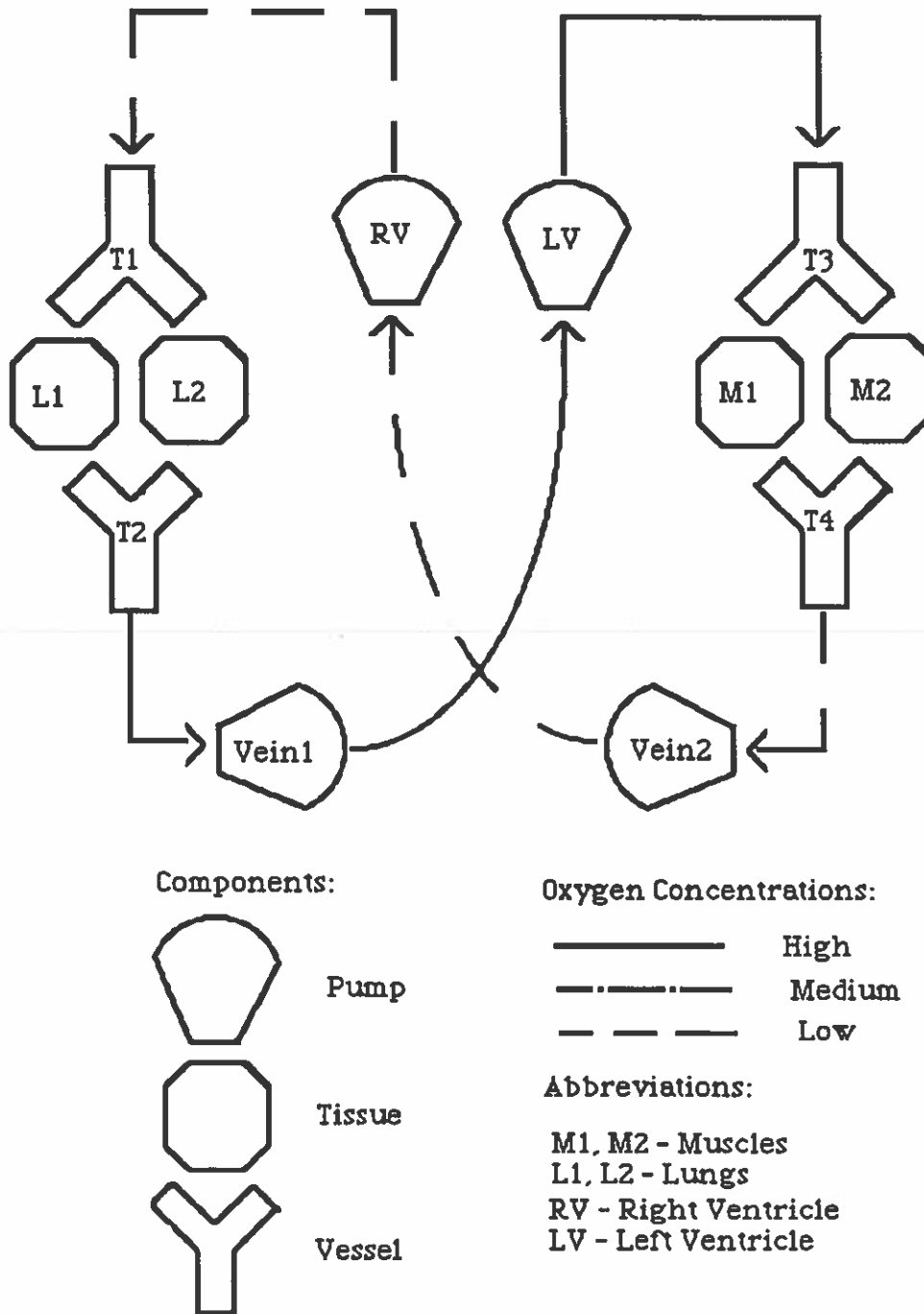

FIGURE 23. Mammalian DEN.

**Priority Level 1:**

Oxygen Transport recommends that producers have pure consumer feed.

Evaluation: Satisfied

Satisfiers:

Lung1 - fed by M1 and M2 (both consumers)

Lung2 - fed by M1 and M2 (both consumers)

Violators: nil

Oxygen Transport recommends that consumers have pure producer feed.

Evaluation: Satisfied

Satisfiers:

M1 - fed by Lung1 and Lung2 (both producers)

M2 - fed by Lung1 and Lung2 (both producers)

Violators: nil

**Priority Level 2:**

Oxygen Transport recommends that producers and consumers have no feedback.

Evaluation: Satisfied

Satisfiers:

M1, M2, Lung1, Lung2 - none of these have feedback

Violators: nil

**FIGURE 24.** Static explanation of the mammalian topology relative to the oxygen-transport teleology.

TABLE 14. Static Explanation Summaries for Mammalian Topology

Transport	Conserve	Dissipate	Accumulate
Pure-c feed to P's -> Satisfy	Flow to P's and C's -> Violate	No feedback to P's -> Satisfy	No feedback to P's -> Violate
Pure-p feed to C's -> Satisfy	Not pure-p feed to P's nor pure-c feed to C's -> Violate	No feedback to C's -> Violate	No feedback to C's -> Satisfy

This completes the zero-order analysis of both circulatory systems. As the examples above indicate, value judgements of circulatory topologies vitally depend upon the teleology, which also supplies the framework for explanation. BIOTIC clearly illustrates the effects of these teleological biases (derived from The Bipartite Teleology Model (BTM)) by providing the diverse analyses of the reptilian and mammalian circulations. The next section illustrates the importance of teleology during regulatory analysis.

#### Regulatory Analysis of the Reptilian and Mammalian Circulations

As shown above, the mammalian circulation clearly dominates the reptilian model relative to zero-order oxygen transport. However, from the first-order perspective, and within the context of certain environments and tasks, the reptile outperforms the mammal. Returning to Burggren's (1987) example of the diving reptile, consider the following critical context for the reptilian model:

(Complete-Topology Oxygen-Transport First-Order Underwater Diving)

This requests a critique of the *complete* reptilian topology relative to dynamic oxygen transport while the organism performs the task of diving in an underwater environment. To analyze the complete topology in this context, BIOTIC enlists CIRC-SIM to perform first-order simulation. The resulting behaviors are then evaluated and explained.

As shown in Chapter IV, the five steps of first-order simulation are (1) environment and task activation, (2) teleology-based resistance alteration, (3) resistance-change integration, (4) flow-influence propagation, and (5) flow-influence resolution. I will now illustrate these operations as applied to the critical context above.

In step one, the environment and task are used to exert primitive influences upon state concentrations and activity levels. In this case, the underwater environment exerts a -1 influence upon  $[O_2]^{state}$  in each lung,

while the diving task entails a -1 influence upon  $[O_2]^{M1-state}$  as well as a +1 influence upon M1's activity level and a -1 influence upon each lung's activity level. This occurs under the composite assumption that (a) reptiles primarily use their tail muscles for water locomotion, (b) M1 represents a tail muscle, and (c) M2 denotes a leg muscle. The influences upon the  $[O_2]^{state}$  values create the oxygen-exchange tendencies of "decreased production" in the lungs, "increased consumption" at M1, and "steady consumption" at M2. Furthermore, the -1 sensitivity of tissue resistances to activity levels leads to a -1 influence upon the resistance of M1, and a +1 influence upon that of Lung1 and Lung2.

The second step is quite simple, since the activity levels have already determined changes for three of the four resistances. The fourth, M2's resistance, requires no change according to Table 3, which CIRC-SIM indexes into with "transport" and "steady consumption". Also, note that the activity-level influences upon the other three resistances agree with the transport teleology's recommendations of Table 3 for "increased consumption" (in M1) and "decreased production" (in the lungs).

In resistance-change integration, the third step, CIRC-SIM propagates resistance influences throughout the GTH. This leads to influences upon aggregate resistances and flow distributions. For instance,  $\partial R(M1)[-1]$  and  $\partial R(M2)[0]$  (i.e., the -1 influence upon M1's resistance, and the zero influence upon M2's resistance) combine with the sensitivities  $S(R(PTU_{T3}), R(M1), +0.5)$  and  $S(R(PTU_{T3}), R(M2), +0.5)$  to yield a net -0.5 influence upon the resistance of the parallel tissue unit containing M1 and M2:  $\partial R(PTU_{T3})[-0.5]$ . Furthermore, the sensitivities of the two  $PTU_{T3}'$  distributors:

$S(\text{Dist}(PTU_{T3}, M1), R(M1), -0.5)$   
 $S(\text{Dist}(PTU_{T3}, M1), R(M2), +0.5)$   
 $S(\text{Dist}(PTU_{T3}, M2), R(M1), +0.5)$   
 $S(\text{Dist}(PTU_{T3}, M2), R(M2), -0.5)$

incur the following distributor influences:

$\partial \text{Dist}(PTU_{T3}, M1)[+0.5]$   
 $\partial \text{Dist}(PTU_{T3}, M2)[-0.5]$

The complete set of resistance and distribution influences appears in Figure 25.



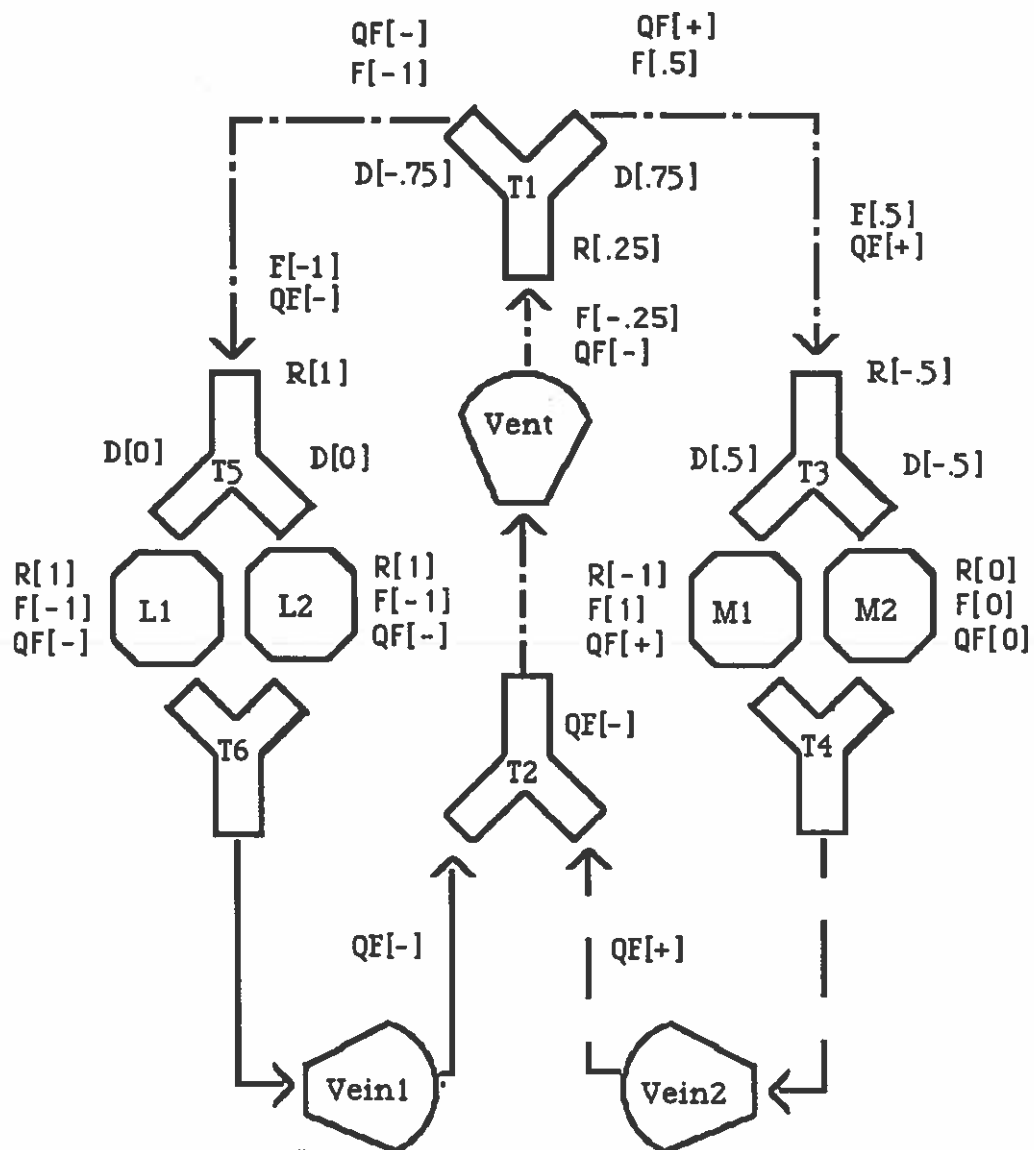

Legend:

$R[n]$  - n resistance influences  
 $F[n]$  - n flow influences  
 $D[n]$  - n flow-distribution influences  
 $QF[s]$  - s=sign of the final qualitative flow change

FIGURE 25. Regulatory simulation of diving reptile.

Next, CIRC-SIM computes the flow influences throughout the circulation. This process begins at the sending pumps of each characteristic flow. The net resistance influence upon a pump is negated to yield the net influence upon its output flow. In this case, the ventricle to veins flow has a net resistance influence of +0.25, so the ventricle's flow output receives a -0.25 influence, which is then propagated along the characteristic flow and combined with the distributor influences along the way. For instance:

1.  $\partial \text{Outflow}(\text{Vent})[-0.25] + \partial \text{Dist}(\text{PTU}_{T1}, T3)[+0.75] \Rightarrow \partial \text{Inflow}(T3)[+0.5]$
2.  $\partial \text{Outflow}(\text{Vent})[-0.25] + \partial \text{Dist}(\text{PTU}_{T1}, T5)[-0.75] \Rightarrow \partial \text{Inflow}(T5)[-1]$

Conversely, the characteristic flows emanating from the two veins contain no tissues and therefore the vein outputs encounter no (modeled) resistance or resistance changes. The net flow influences for each characteristic flow also appear in Figure 25.

Finally, in step five, CIRC-SIM uses the quantitative net flow influences as weights upon the variables of qualitative flow-conservation constraints, which it passes to the weighted-qualitative-constraint satisfier. This returns a perfusion decrease to the lungs, an increase to M1, and no change to M2 - just as desired by the teleology. These and other qualitative flow changes are also part of Figure 25.

In sum, the resistance changes affect a decrease in the flow out of the reptile's ventricle, and a significant redistribution(at T1) of blood away from the lungs and toward the muscles. In physiological terminology, this constitutes a "right-to-left shunt", since after leaving the ventricle, a greater percentage of blood branches to the left (toward the body) than to the right (toward the lungs)<sup>3</sup> This is the same qualitative behavior as observed in diving reptiles (Burggren, 1987).

Having completed simulation, BIOTIC now turns to criticism. The first stage, evaluation, produces the ratings of Table 15, which are based on the recommended perfusion changes of Table 3.

---

<sup>3</sup> In medical terminology, 'right' and 'left' are relative to the organism. Hence, in these examples, directions are the reverse of their orientation on the page relative to the reader.

TABLE 15. Evaluation of Diving Reptile According to First-Order Oxygen Transport

Tissue	Tendency	Teleo-based Flow Change	Actual Flow Change	Teleo-Based Rating
L1	Decr. Prod	Decr	Decr	1
L2	Decr Prod	Decr	Decr	1
M1	Incr CsmP	Incr	Incr	1
M2	Steady CsmP	Steady	Steady	1
Global Eval:				1.0

Next, BIOTIC explains the perfusion changes in terms of (a) the causal pathways from resistance changes to distributor and pump-output influences, and then back to perfusion changes, and (b) the flowpath relations of the circulatory topology. The causal-explanation phase yields the organized trace of Figure 26.

The explanation in Figure 26 captures the four important interaction types that occur within the ventricle-to-veins characteristic flow. The proliferation of causal activity precludes any simple explanation in terms of a linear causal chain, although a fairly complex causal network might suffice. Instead, I chose the above format to highlight the four interaction classes, which form a fairly linear causal chain at a more abstract level. Namely, local resistance perturbations incur changes in aggregate resistance and flow distribution. Then, aggregate resistances eventually affect pump outputs. Finally, distribution effects combine with pump-output changes to influence local perfusion rates.

In *structural justification*, the second mode of regulatory explanation, BIOTIC attempts to rationalize perfusion changes in terms of the flowpath topology: serial and parallel relationships between tissues and/or tissue groups. This highlights the connections between teleology, topology and behavior. BIOTIC's analysis of the diving reptile produces five "interesting" topological relationships, which are paraphrased in Figure 27 (underlined words represent the important criteria for topological analysis, and *italicized words* are fillers for those important slots).

In the structural justification of Figure 27, note that items 1 and 3 pinpoint flowpath relationships of teleological significance, while items 2,4 and 5 focus on the basic regulatory behaviors (i.e., actual and desired perfusion changes) and how the topology constrains them. Thus, structural justification has both a behavioral and a teleological component, as discussed in Chapter IV.

Local Resistance Influences:

- 1) The task of diving and its concomitant activity-level changes cause:
  - a)  $\partial R(M1)[-1]$
  - b)  $\partial R(Lung1)[+1]$
  - c)  $\partial R(Lung2)[+1]$
- 2) The oxygen-transport teleology causes:
  - a)  $\partial R(M2)[0]$

Parallel Tissue Unit Interactions:

- 1) At  $PTU_{T3}$ ,  $\partial R(M1)[-1]$  and  $\partial R(M2)[0]$  cause:
  - a)  $\partial R(PTU_{T3})[-0.5]$
  - b)  $\partial Dist(PTU_{T3}, M1)[+0.5]$
  - c)  $\partial Dist(PTU_{T3}, M2)[-0.5]$
- 2) At  $PTU_{T5}$ ,  $\partial R(Lung1)[+1]$  and  $\partial R(Lung2)[+1]$  cause:
  - a)  $\partial R(PTU_{T5})[+1]$
  - b)  $\partial Dist(PTU_{T5}, Lung1)[0]$
  - c)  $\partial Dist(PTU_{T5}, Lung2)[0]$
- 3) At  $PTU_{T1}$ ,  $\partial R(PTU_{T3})[-0.5]$  and  $\partial R(PTU_{T5})[+1]$  cause:
  - a)  $\partial R(PTU_{T1})[+0.25]$
  - b)  $\partial Dist(PTU_{T1}, PTU_{T3})[+0.75]$
  - c)  $\partial Dist(PTU_{T1}, PTU_{T5})[-0.75]$

Pump-Output Influences:

- 1)  $\partial R(PTU_{T1})[+0.25]$  causes  $\partial Flowout(Vent)[-0.25]$

Local Perfusion Influences:

- 1)  $\partial Flowout(Vent)[-0.25]$ ,  $\partial Dist(PTU_{T1}, PTU_{T5})[-0.75]$ , and  $\partial Dist(PTU_{T5}, Lung1)[0]$  cause:
  - a)  $\partial Perfusion(Lung1)[-1]$
- 2)  $\partial Flowout(Vent)[-0.25]$ ,  $\partial Dist(PTU_{T1}, PTU_{T5})[-0.75]$ , and  $\partial Dist(PTU_{T5}, Lung2)[0]$  cause:
  - a)  $\partial Perfusion(Lung2)[-1]$
- 3)  $\partial Flowout(Vent)[-0.25]$ ,  $\partial Dist(PTU_{T1}, PTU_{T3})[+0.75]$  and  $\partial Dist(PTU_{T3}, M1)[+0.5]$  cause:
  - a)  $\partial Perfusion(M1)[+1]$
- 4)  $\partial Flowout(Vent)[-0.25]$ ,  $\partial Dist(PTU_{T1}, PTU_{T3})[+0.75]$  and  $\partial Dist(PTU_{T3}, M2)[-0.5]$  cause:
  - a)  $\partial Perfusion(M2)[0]$

FIGURE 26. Causal trace of regulatory behavior in diving reptile.

1. Group (Lung1 Lung2) with the tendency of decreased production has an indirect parallel flowpath relationship to M2, which has a tendency of steady consumption. This satisfies the teleology-recommended parallel relationship (from Table 5).
2. Group (Lung1, Lung2) with a desired decrease in perfusion and an actual decrease in perfusion has an indirect parallel flowpath relationship to M2, which has a desired steady perfusion rate and an actual steady perfusion rate. This is an example of a parallel relationship enabling disparate flow changes.
3. Group (Lung1 Lung2) with the tendency of decreased production has an indirect parallel flowpath relationship to M1, which has a tendency of increased consumption. This satisfies the teleology-recommended parallel relationship (from Table 5).
4. Group (Lung1, Lung2) with a desired decrease in perfusion and an actual decrease in perfusion has an indirect parallel flowpath relationship to M1, which has a desired increase in perfusion and an actual increase in perfusion. This is an example of a parallel relationship enabling disparate flow changes.
5. M1 with a desired increase in perfusion and an actual increase in perfusion has a direct parallel flowpath relationship to M2, which has a desired steady perfusion rate and an actual steady perfusion rate. This is an example of a parallel relationship enabling disparate flow changes.

FIGURE 27. Structural justification of regulatory behaviors in diving reptile relative to the oxygen-transport teleology.

As a whole, BIOTIC's explanation of reptilian regulatory behavior during diving presents a host of essential causal interactions and salient topological relationships. This conveys a basic understanding of dynamic circulatory behavior through the integration of structure, behavior and function.

### The Diving Mammal

Returning to the mammalian circulation, consider the same critical context as for the reptile, except that the interpretation becomes the sole mammalian flow pattern, also known as the *mammalian topology*. Also, the tissue components need a slight reinterpretation: assume M1 is an arm and that the mammal primarily uses its arms for water movement. M2 remains a leg.

First-order simulation then proceeds as follows: when diving underwater, the same  $[O_2]^{state}$  and activity-level changes occur as in the reptilian example. This incurs the same tendencies and teleological flow recommendations as before. However, the differences between the mammalian and reptilian topology become apparent in the final three stages of regulatory simulation. To wit, in the mammalian topology, the diverse flow demands between the lungs and muscles lead to a dilemma: the overall resistance to the left ventricle's flow decreases, while the right ventricle's resistance goes up. Hence, RV's flow should decrease, while LV's flow should rise. Since these two flows lie in series (when connected via the flows from Vein1 to LV and Vein2 to RV), the circulation cannot sustain an increase in one coupled with a decrease in the other. They must change in the same direction.

Since two resistances increased in the pulmonary region, while only one decreased in the systemic area, the influence to decrease flow throughout the circulatory loop exceeds the influence to increase flow. Hence, during flow-influence resolution(step 5), "decreased flow" has greater weight than "increased flow"; the constraint satisfier therefore rules in favor of the decrease. Figure 28 summarizes the results of first-order simulation, while Table 16 presents the final perfusion changes along with their evaluations.

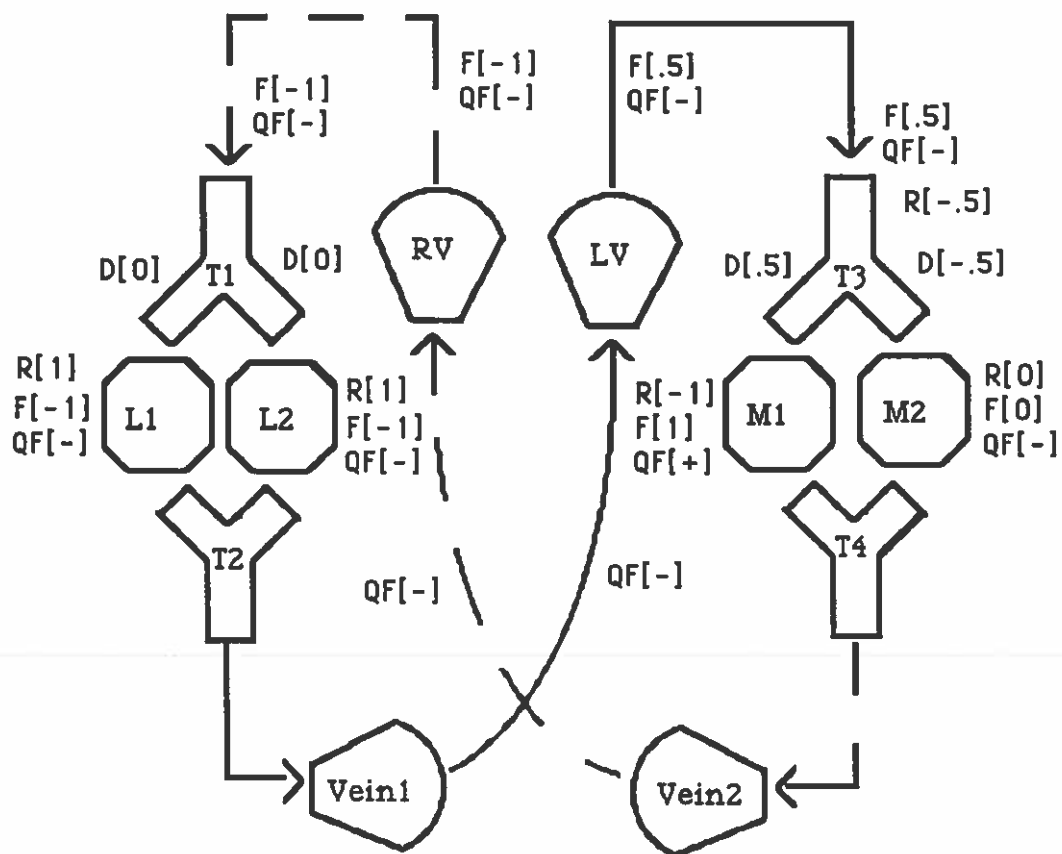

Legend:

R[n] - n resistance influences

F[n] - n flow influences

D[n] - n flow-distribution influences

QF[s] - s=sign of the final qualitative flow change

FIGURE 28. Regulatory simulation of diving mammal.

TABLE 16. Evaluation of Diving Mammal According to First-Order Oxygen Transport

Tissue	Tendency	Teleo-based Flow Change	Actual Flow Change	Teleo-Based Rating
L1	Decr. Prod	Decr	Decr	1
L2	Decr Prod	Decr	Decr	1
M1	Incr Consmg	Incr	Incr	1
M2	Steady Consmg	Steady	Decr	0
Global Eval:				0.75

Basically, the qualitative constraints enable Perfusion(M1) to increase, even though Flowin(T3) drops; but Perfusion(M2) cannot simultaneously hold steady. Hence, all four tissues cannot jointly receive their desired perfusion changes. BIOTIC's causal explanation appears in Figure 29.

So, according to the local interactions of Figure 29, each tissue should achieve its desired perfusion change. However, the serial relationship between the pulmonary and systemic regions precludes such mutual satisfaction. The causal explainer misses that conflict, but the structural justification phase of explanation focuses on the final globally-consistent perfusion changes (returned by the qualitative constraint satisfier) in judging the topological contributions to behavior and purpose. Structural justification uncovers three interesting relationships as shown in Figure 30.



Local Resistance Influences:

- 1) The task of diving and its concomitant activity-level changes cause:
  - a)  $\partial R(M1)[-1]$
  - b)  $\partial R(Lung1)[+1]$
  - c)  $\partial R(Lung2)[+1]$
- 2) The oxygen-transport teleology causes:
  - a)  $\partial R(M2)[0]$

Parallel Tissue Unit Interactions:

- 1) At  $PTU_{T3}$ ,  $\partial R(M1)[-1]$  and  $\partial R(M2)[0]$  cause:
  - a)  $\partial R(PTU_{T3})[-0.5]$
  - b)  $\partial Dist(PTU_{T3}, M1)[+0.5]$
  - c)  $\partial Dist(PTU_{T3}, M2)[-0.5]$
- 2) At  $PTU_{T1}$ ,  $\partial R(Lung1)[+1]$  and  $\partial R(Lung2)[+1]$  cause:
  - a)  $\partial R(PTU_{T1})[+1]$
  - b)  $\partial Dist(PTU_{T1}, Lung1)[0]$
  - c)  $\partial Dist(PTU_{T1}, Lung2)[0]$

Pump-Output Influences:

- 1)  $\partial R(PTU_{T1})[+1]$  causes  $\partial Flowout(RV)[-1]$
- 2)  $\partial R(PTU_{T3})[-0.5]$  causes  $\partial Flowout(LV)[+0.5]$

Local Perfusion Influences:

- 1)  $\partial Flowout(RV)[-1]$  and  $\partial Dist(PTU_{T1}, Lung1)[0]$  cause:
  - a)  $\partial Perfusion(Lung1)[-1]$
- 2)  $\partial Flowout(RV)[-1]$  and  $\partial Dist(PTU_{T1}, Lung2)[0]$  cause:
  - a)  $\partial Perfusion(Lung2)[-1]$
- 3)  $\partial Flowout(LV)[+0.5]$  and  $\partial Dist(PTU_{T3}, M1)[+0.5]$  cause:
  - a)  $\partial Perfusion(M1)[+1]$
- 4)  $\partial Flowout(LV)[+0.5]$  and  $\partial Dist(PTU_{T3}, M2)[-0.5]$  cause:
  - a)  $\partial Perfusion(M2)[0]$

FIGURE 29. Causal trace of regulatory behavior in diving mammal.

1. Group (Lung1 Lung2) with the tendency of decreased production has a non-absolute serial flowpath relationship to M2, which has a tendency of steady consumption. This partially satisfies the teleology-recommended parallel relationship (from Table 5).
2. Group (Lung1, Lung2) with a desired decrease in perfusion and an actual decrease in perfusion has a non-absolute serial flowpath relationship to M2, which has a desired steady perfusion rate and an actual decrease in perfusion. This is an example of a serial relation deterring disparate flow demands.
3. Group (Lung1 Lung2) with the tendency of decreased production has an non-absolute serial flowpath relationship to M1, which has a tendency of increased consumption. This partially satisfies the teleology-recommended parallel relationship.

FIGURE 30. Structural justification of regulatory behaviors in diving mammal relative to the oxygen-transport teleology.

Hence, from the qualitative standpoint, the serialism of L1-L2 and M1-M2 prohibits the mutual satisfaction of all perfusion-change demands, but the parallelism of M1 and M2 does enable one of them, M1, to receive a different qualitative flow change than that of L1-L2.

Through these critiques, BIOTIC highlights the critical distinction between the mammalian and reptilean circulatory topologies: serial versus parallel pulmonary and systemic regions. By critiquing both systems from two teleological perspectives (i.e., static and dynamic), the differential functionalities of each topology become evident. These functionalities and their relationships to topology closely mirror those discussed by Burggren (1987).

### The Heavy-Breathing Reptile

As another comparison of BIOTIC to Burggren, consider the "left-to-right" shunt that occurs in reptiles during periods of high lung ventilation (e.g., immediately following a lengthy underwater swim). Burggren indicates that this shunt stimulates the dissipation of carbon dioxide from the blood. In BIOTIC, this maps into the following critical context:

(Complete-Topology CO<sub>2</sub>-Dissipation First-Order Land  
Heavy-Breathing)

In BIOTIC, the "land" environment is basically a vacuous environment, since it entails no activity-level or state-concentration perturbations. Conversely, the task of heavy breathing implies that the activity levels of the lungs will rise, while pulmonary

[CO<sub>2</sub>]<sup>state</sup> will fall. Hence, both lungs will have high carbon-dioxide-consumption tendencies, while the production tendencies of the muscles should be normal. The rising pulmonary activity levels will lower pulmonary resistance; and this corresponds to the recommendations of dissipation in Table 3. Also, the teleology advocates a decrease in systemic flow - and thus a rise in systemic resistance. Through steps 3-5 of first-order simulation, CIRC-SIM converts these resistance changes into perfusion changes. BIOTIC then forms the evaluation of Table 17, which shows that the reptilian circulatory model perfectly executes the left-to-right shunt. BIOTIC's causal explanation appears in Figure 31.

TABLE 17. Evaluation of Heavy-Breathing Reptile According to Dynamic CO<sub>2</sub> Dissipation

Tissue	Tendency	Teleo-based Flow Change	Actual Flow Change	Teleo-Based Rating
L1	Incr Consmp	Incr	Incr	1
L2	Incr Consmp	Incr	Incr	1
M1	Steady Prod	Decr	Decr	1
M2	Steady Prod	Decr	Decr	1
Global Eval:				1.0

Next, during structural justification (see Figure 32), BIOTIC treats the muscle and lung groups as primitives, due to the similarities within each region. This condenses the set of interesting relationships down to one, which holds relevance from both the behavioral and teleological angle.

#### The Heavy-Breathing Mammal

Given the same critical context, the mammalian circulation again exhibits a major conflict between the flow demands of the pulmonary and systemic regions. The serialism of the two regions prevents the mutual satisfaction of each local perfusion demand and leads to flow behaviors and evaluations of Table 18.

**Local Resistance Influences:**

- 1) The task of heavy breathing and its concomitant activity-level changes cause:
  - a)  $\partial R(\text{Lung1})[-1]$
  - b)  $\partial R(\text{Lung2})[-1]$
- 2) The carbon-dioxide dissipation teleology causes:
  - a)  $\partial R(\text{M1})[+1]$
  - b)  $\partial R(\text{M2})[+1]$

**Parallel Tissue Unit Interactions:**

- 1) At  $\text{PTU}_{\text{T3}}$ ,  $\partial R(\text{M1})[+1]$  and  $\partial R(\text{M2})[+1]$  cause:
  - a)  $\partial R(\text{PTU}_{\text{T3}})[+1]$
  - b)  $\partial \text{Dist}(\text{PTU}_{\text{T3}}, \text{M1})[0]$
  - c)  $\partial \text{Dist}(\text{PTU}_{\text{T3}}, \text{M2})[0]$
- 2) At  $\text{PTU}_{\text{T5}}$ ,  $\partial R(\text{Lung1})[-1]$  and  $\partial R(\text{Lung2})[-1]$  cause:
  - a)  $\partial R(\text{PTU}_{\text{T5}})[-1]$
  - b)  $\partial \text{Dist}(\text{PTU}_{\text{T5}}, \text{Lung1})[0]$
  - c)  $\partial \text{Dist}(\text{PTU}_{\text{T5}}, \text{Lung2})[0]$
- 3) At  $\text{PTU}_{\text{T1}}$ ,  $\partial R(\text{PTU}_{\text{T3}})[+1]$  and  $\partial R(\text{PTU}_{\text{T5}})[-1]$  cause:
  - a)  $\partial R(\text{PTU}_{\text{T1}})[0]$
  - b)  $\partial \text{Dist}(\text{PTU}_{\text{T1}}, \text{PTU}_{\text{T3}})[-1]$
  - c)  $\partial \text{Dist}(\text{PTU}_{\text{T1}}, \text{PTU}_{\text{T5}})[+1]$

**Pump-Output Influences:**

- 1)  $\partial R(\text{PTU}_{\text{T1}})[0]$  causes  $\partial \text{Flowout}(\text{Vent})[0]$

**Local Perfusion Influences:**

- 1)  $\partial \text{Flowout}(\text{Vent})[0]$ ,  $\partial \text{Dist}(\text{PTU}_{\text{T1}}, \text{PTU}_{\text{T5}})[+1]$ , and  $\partial \text{Dist}(\text{PTU}_{\text{T5}}, \text{Lung1})[0]$  cause:
  - a)  $\partial \text{Perfusion}(\text{Lung1})[+1]$
- 2)  $\partial \text{Flowout}(\text{Vent})[0]$ ,  $\partial \text{Dist}(\text{PTU}_{\text{T1}}, \text{PTU}_{\text{T5}})[+1]$ , and  $\partial \text{Dist}(\text{PTU}_{\text{T5}}, \text{Lung2})[0]$  cause:
  - a)  $\partial \text{Perfusion}(\text{Lung2})[+1]$
- 3)  $\partial \text{Flowout}(\text{Vent})[0]$ ,  $\partial \text{Dist}(\text{PTU}_{\text{T1}}, \text{PTU}_{\text{T3}})[-1]$  and  $\partial \text{Dist}(\text{PTU}_{\text{T3}}, \text{M1})[0]$  cause:
  - a)  $\partial \text{Perfusion}(\text{M1})[-1]$
- 4)  $\partial \text{Flowout}(\text{Vent})[0]$ ,  $\partial \text{Dist}(\text{PTU}_{\text{T1}}, \text{PTU}_{\text{T3}})[-1]$  and  $\partial \text{Dist}(\text{PTU}_{\text{T3}}, \text{M2})[0]$  cause:
  - a)  $\partial \text{Perfusion}(\text{M2})[-1]$

FIGURE 31. Causal trace of regulatory behavior in heavy-breathing reptile.

1. Group (Lung1 Lung2) with the tendency of increased consumption has a direct parallel flowpath relationship to Group (M1 M2), which has a tendency of steady production. This *satisfies* the teleology-recommended parallel relationship (from Table 5).
2. Group (Lung1, Lung2) with a desired increase in perfusion and an actual increase in perfusion has a direct parallel flowpath relationship to Group (M1 M2), which has a desired decreased perfusion rate and an actual decrease in perfusion. This is an example of a parallel relationship enabling disparate flow demands.

FIGURE 32. Structural justification of regulatory behavior in heavy-breathing reptile relative to the CO<sub>2</sub>-dissipation teleology.

TABLE 18. Evaluation of Heavy-Breathing Mammal According to Dynamic CO<sub>2</sub> Dissipation

Tissue	Tendency	Teleo-based Flow Change	Actual Flow Change	Teleo-Based Rating
L1	Incr Consmp	Incr	Incr	1
L2	Incr Consmp	Incr	Incr	1
M1	Steady Prod	Decr	Incr	-1
M2	Steady Prod	Decr	Decr	1
Global Eval:				0.5

Again, BIOTIC traces the basic causal interaction along with highlighting the pivotal flowpath relationships, as shown in Figure 33.

Local Resistance Influences:

- 1) The task of heavy breathing and its concomitant activity-level changes cause:
  - a)  $\partial R(\text{Lung1})[-1]$
  - b)  $\partial R(\text{Lung2})[-1]$
- 2) The carbon-dioxide dissipation teleology causes:
  - a)  $\partial R(\text{M1})[+1]$
  - b)  $\partial R(\text{M2})[+1]$

Parallel Tissue Unit Interactions:

- 1) At  $\text{PTU}_{\text{T3}}$ ,  $\partial R(\text{M1})[+1]$  and  $\partial R(\text{M2})[+1]$  cause:
  - a)  $\partial R(\text{PTU}_{\text{T3}})[+1]$
  - b)  $\partial \text{Dist}(\text{PTU}_{\text{T3}}, \text{M1})[0]$
  - c)  $\partial \text{Dist}(\text{PTU}_{\text{T3}}, \text{M2})[0]$
- 2) At  $\text{PTU}_{\text{T1}}$ ,  $\partial R(\text{Lung1})[-1]$  and  $\partial R(\text{Lung2})[-1]$  cause:
  - a)  $\partial R(\text{PTU}_{\text{T1}})[-1]$
  - b)  $\partial \text{Dist}(\text{PTU}_{\text{T1}}, \text{Lung1})[0]$
  - c)  $\partial \text{Dist}(\text{PTU}_{\text{T1}}, \text{Lung2})[0]$

Pump-Output Influences:

- 1)  $\partial R(\text{PTU}_{\text{T1}})[-1]$  causes  $\partial \text{Flowout}(\text{RV})[+1]$
- 2)  $\partial R(\text{PTU}_{\text{T3}})[+1]$  causes  $\partial \text{Flowout}(\text{LV})[-1]$

Local Perfusion Influences:

- 1)  $\partial \text{Flowout}(\text{RV})[+1]$  and  $\partial \text{Dist}(\text{PTU}_{\text{T1}}, \text{Lung1})[0]$  cause:
  - a)  $\partial \text{Perfusion}(\text{Lung1})[+1]$
- 2)  $\partial \text{Flowout}(\text{RV})[+1]$  and  $\partial \text{Dist}(\text{PTU}_{\text{T1}}, \text{Lung2})[0]$  cause:
  - a)  $\partial \text{Perfusion}(\text{Lung2})[+1]$
- 3)  $\partial \text{Flowout}(\text{LV})[-1]$  and  $\partial \text{Dist}(\text{PTU}_{\text{T3}}, \text{M1})[0]$  cause:
  - a)  $\partial \text{Perfusion}(\text{M1})[-1]$
- 4)  $\partial \text{Flowout}(\text{LV})[-1]$  and  $\partial \text{Dist}(\text{PTU}_{\text{T3}}, \text{M2})[0]$  cause:
  - a)  $\partial \text{Perfusion}(\text{M2})[-1]$

FIGURE 33. Causal trace of regulatory behavior in heavy-breathing mammal.

Once again, only three of the four local perfusion influences reflect the final qualitative perturbation changes. As depicted in item 2 of Figure 34, structural justification then notices the serial relationship which prevented the realization of all four perfusion demands:

1. Group (Lung1 Lung2) with the tendency of increased consumption has an absolute serial flowpath relationship to Group (M1 M2), which has a tendency of steady production. This *violates* the teleology-recommended *parallel* relationship (from Table 5).
2. Group (Lung1, Lung2) with a desired increase in perfusion and an actual increase in perfusion has a non-absolute serial flowpath relationship to M1, which has a desired decreased perfusion rate and an actual increase in perfusion. This is an example of a *serial relationship deterring disparate flow demands*.

FIGURE 34. Structural justification of regulatory behavior in heavy-breathing mammal relative to the CO<sub>2</sub>-dissipation teleology.

In the structural justification above, note that M1 and M2 are grouped for teleology-driven justification, since they have the same tendency. However, they have different *actual* perfusion changes and therefore are not grouped during behavior-based justification.

Once again, the serial mammalian topology loses to the parallel reptilian model from the regulatory perspective. In general, the greater the parallelism in a system, the better chance it will have of satisfying all perfusion requests. However, parallelism does not guarantee agreement with the teleology's topological relationships. For instance, if the environment were land and the task were running, then the muscles and lungs would both have elevated activity levels and exchange tendencies. Hence, a transport teleology would recommend a serial relationship between the two regions. So although the reptile could increase flow to all regions, it would not satisfy the prescribed serial relationship. This is an important point, because in general, mammals perform more strenuous activities and demand greater simultaneous increases in pulmonary and systemic blood flow than do reptiles. A serial topology satisfies these demands by pumping all of the blood through each region; but the splitting of flow in a parallel topology greatly decreases the quantitative magnitude of each perfusion increase. Thus, serial topologies also have regulatory significance. And although a parallel topology might receive a perfect evaluation (based on its qualitative perfusion changes) during running, its violation of the serial recommendation would hint of a potential problem.

### Summary

The sequence of examples in this chapter traces a small slice of the history of circulatory physiology in that reptiles were once considered inferior to mammals due to their parallel circulatory systems. A comparison of

the zero-order evaluations for the reptilian-complete and mammalian topologies reflects that inferiority and pinpoints its cause: the mixing of pulmonary and systemic blood. However, recent evidence suggests (Burggren, 1987) that a parallel circulation (and the left-to-right and right-to-left shunts that it enables) has significant functionality during stereotypically reptilian activities such as prolonged diving, post-dive recovery, sun basking, etc. The regulatory examples above clearly indicate the qualitative advantages of reptilian blood shunting during diving and post-dive recovery, as well as the disadvantages of a serial topology in those contexts. Hence, BIOTIC accounts for a wide enough range of environments, tasks, teleologies and perspectives to produce many different physiologically-accurate critiques of the same system; and most importantly, it does so without the plethora of quantitative data and equations normally required for cardiovascular simulation and criticism.

BIOTIC produces critiques similar to those of Burggren (1987) and other physiologists (Eckert, Randall and Augustine, 1988, pp. 446-450) by formalizing (via BTM) and operationalizing the notions of teleology and perspective that are essential, fundamental, yet implicit aspects of those expert' critiques. This illustrates the utility of the Bipartite Teleological Model in analyzing flow-and-diffusion-based systems.

Also note that BIOTIC deals equally well with negative and positive instances of a teleology (i.e., systems that violate or satisfy that teleology, respectively). In either case, it simulates the system, makes an evaluation and forms an explanation.

In general, the ability to critique from multiple contexts and to handle negative and positive instances makes BIOTIC a useful tool in analyzing systems that exhibit function sharing. Although BIOTIC does not deal very well with simultaneous teleologies, it can understand a system relative to each teleology in isolation. In a function-sharing system, the view from any one teleological angle may be less than optimal, since the system designer probably had to make compromises to incorporate multiple purposes. Hence, many critical contexts will turn up negative instances. Thus, BIOTIC's ability to explain these instances greatly improves its handling of function-sharing systems.

Furthermore, BIOTIC illustrates the role of teleology in organizing the structures and behaviors of a complex system into a meaningful, comprehensive description. To wit, the teleology provides a schema of behavioral and structural expectations/recommendations. These biases, which originate in BTM, tell BIOTIC what to look for. Different teleologies and perspectives recommend different things. A static transport topology searches for consumers and producers upstream from one another, while a static dissipative teleology prefers consumer feedbacks in the absence of producer feedbacks. Similarly, from the dynamic perspective, BIOTIC hunts for behaviors and topological arrangements that vary with the teleology. In a circulatory system, the topological relationship between any two components has some causal significance, but BTM enables BIOTIC to focus on just the most salient relationships within a system. This condenses the explanation down to a more manageable, understandable portrayal of the working system.

Finally, BIOTIC's first-principle basis enables it to critique many systems other than the reptilian, crocodilian and mammalian circulations. For instance, Appendix C shows a critique of the "Strange Topology", while many other even stranger topologies have been successfully analyzed by BIOTIC. In short, The Biology Critic gives another indication of the flexibility and



robustness of a first-principled approach to qualitative simulation and reasoning. In addition, it helps clarify the qualitative relationships between first-principle models of structure, behavior and function.

As an implementation note, BIOTIC runs in Allegro Common Lisp on an Apple Macintosh II. Table 19 summarizes the results of running BIOTIC on six different circulatory models:

TABLE 19. Summary of BIOTIC Runs

Model	# Components	# Flow Interps	Pulsatile Time (secs)	Steady-state Time (secs)	Regulatory Time (secs)
Crocodile 1	30	9	66.83	9.32	30.17
Crocodile 2	31	3	23.27	9.22	26.02
Reptile	19	3	9.97	11.83	28.53
Mammal	16	1	5.05	8.88	51.98
Strange	21	3	9.74	9.85	27.65
Slosh	23	1	6.62	15.45	50.05

In Table 19, "pulsatile time" refers to the time required to generate all of the flow topologies and abstract them into PC topologies. "Steady-state" time captures the duration of zero-order entity passing (of a single entity through a single flow topology) along with the time to print out the evaluation and explanation. Output generally requires all but a few tenths of a second of the total steady-state time. Finally, "regulatory time" denotes the time to perform regulatory simulation (upon a single flow topology) and to output the evaluation and explanation. In this case, output takes approximately half of the total regulatory time. During the weighted-constraint satisfaction stage of regulatory simulation, an inefficient ATMS (i.e., no bit-coding of assumptions) greatly contributes to the delay.

## CHAPTER VI

## CRITIQUING THE BIOLOGY CRITIC

As emphasized at the outset, this research attempts to automate circulatory criticism via a combination of qualitative and teleological analysis. This chapter gauges the success of that endeavor by assessing the utility of BIOTIC's primitive structural, behavioral and teleological concepts in analyzing circulatory systems. This evaluation indicates BIOTIC's strengths and limitations, as well as pointing out important future research.

Unlike simulation, which is essentially a predictive process whose results can be objectively evaluated via comparison to those of the modeled physical system, criticism exhibits more subjectivity. That is, different people often critique the same system in different ways. These critical disparities frequently stem from differences in teleologies or teleological perspectives. Also, they may result from different ways of operationalizing the same critical context, especially in domains such as physiology where few well-defined functional decomposition rules exist. Although no absolute criteria exist for assessing the results of a circulatory critic, we can gain some degree of confidence or doubt in those results by comparing them to the critiques of expert physiologists. This chapter involves such a comparison.

Before commencing this critique of the Biology Critic, I must defend this research by noting that only a small subset of physiological phenomena can be feasibly accounted for in any one thesis project. Still, the intimidating complexities of cardiovascular physiology did not preclude the automation of a restricted form of circulatory criticism: the abstract analysis of the circulation as a producer-consumer network. The producer-consumer perspective facilitates the automation of a few general critical techniques implicit in the work of Burggren and others - namely, the focus on circulatory topology and its role in determining entity-exchange behavior and teleological satisfaction.

Through a plethora of abstractions and modeling assumptions, I have operationalized these notions of teleology and topology within a circulatory critic that exceeds the capabilities of many prototype systems but falls short of a truly robust critic. So at this midway point in my research, it seems necessary to evaluate BIOTIC's approach before attempting to scale it up to richer circulatory models and/or other domains entirely. Hence, the comparisons of this chapter serve more as intermediate feedback than as final judgements.

Furthermore, this work makes no psychological claims. Hence, it is no disgrace to find that BIOTIC's critiques bear only mild similarity to those of experts. Still, I had hoped to achieve some success in automated physiological analysis, and, as mentioned above, that success would be difficult to claim without some similarities between BIOTIC's results and those of the experts. The similarities exist, but the main successes of this work remain at the theoretical level. Essentially, I have gleaned a small set of primitive structures, behaviors and teleologies from the physiology literature and used them to construct

critiques in a restricted domain. This has enabled me to make significant contributions to qualitative physics via the Bipartite Teleology Model (BTM), its operationalization, and the integration of structure, behavior and function during physical-system analysis.

I am now turning back to the physiology to (a) pinpoint the features and bugs of the current implementation, and (b) indicate important physiological concepts whose incorporation could improve BTM and BIOTIC and extend their range of application. Since the basic principles of BTM were inspired by Burggren's research, I will begin by reviewing that work in evaluating BIOTIC. Furthermore, I asked two local physiologists to critique the mammalian and reptilian topologies (along with a novel topology) relative to some of the same critical contexts as in the previous chapter. As hoped, these evaluations highlight BIOTIC's pros and cons and illuminate the relevant pathways of future investigation.

### Burggren's Critiques

In his paper, "Form and Function in Reptilian Circulations," Burggren takes a functional approach to justifying the structure/form of the reptilian circulation, in particular, he hypothesizes various teleologies that the parallel systemic and pulmonary regions might support. As summarized in Table 20, BIOTIC understands half of these teleologies.

First, Burggren discusses ventilation-perfusion matching:

A fundamental premise of gas exchange theory is that gas transfer is most efficient when perfusion and ventilation of the respiratory organ are optimally matched. In animals with continually high metabolic rates (e.g., homeotherms), lung ventilation tends to be a continuous process, variable within comparatively narrow limits. Consequently, lung perfusion also tends to be continuous and comparatively non-variable. Air breathing poikilotherms (i.e., "cold-blooded" animals), on the other hand, tend to have considerably lower metabolic rates and can often serve their respiratory demands using non-continuous breathing patterns. Optimal matching of perfusion with this intermittent ventilation is produced by large adjustments in blood flow to the gas exchange organs. (p. 11)

Burggren goes on to note that ventilation-perfusion matching alone does not necessitate a parallel circulation, since simple adjustments in cardiac output can accommodate different pulmonary perfusion demands. However, if those demands differ from the systemic perfusion needs, then cardiac-output modifications alone cannot satisfy both demands in a non-parallel topology. In short, both ventilation-perfusion matching in the lungs, and metabolism-perfusion matching in the muscles are key elements of efficient gas transport. Burggren does not even question the importance of this matching and therefore does not include it as one of his five hypothetical functionalities of the reptilian circulation; rather, it appears as a well-accepted premise of gas-exchange theory.

TABLE 20. Comparing Burggren's Teleologies to BIOTIC's Capabilities

Burggren's Teleologies	Does BIOTIC Handle It?
Ventilation-Perfusion Matching	Yes
Energy Conservation	No
Oxygen Metering	No
Pulmonary Edema Prevention	No
Carbon Dioxide Dissipation	Yes
Thermal Regulation	Yes

In BTM, ventilation-perfusion and metabolism-perfusion matching are accounted for by many of the flow-change recommendations of Table 3. Appropriately, all six recommendations for the transport teleology embody matching, while conservation runs contrary to matching: high exchange merits low perfusion. Dissipation and accumulation have both matching-enhancing and matching-inhibiting recommendations. Most importantly, BIOTIC can criticize circulatory systems relative to ventilation-perfusion and metabolism-perfusion concerns simply by employing the transport teleology.

Burggren's first hypothetical reptilian teleology is energy conservation (p. 13): "Pulmonary bypass saves cardiac energy during apnea". In short, the circulation wastes energy by sending a lot of blood to a poorly ventilated lung ("apnea" means "low ventilation"). However, Burggren argues mathematically that the energy savings of ventilation-perfusion matching are quite minimal. Regardless, this constitutes an interesting teleology, and one that should be modeled by a circulatory critic.

Unfortunately, BIOTIC only uses the energy conservation teleology implicitly, in that tendency-perfusion matches signal an energy-efficient transport process. Explicitly, BIOTIC does not deal very well with energy as an entity and is therefore incapable of providing a qualitative version of Burggren's quantitative refutation of the energy-conservation hypothesis. Hence, energy-conservation critiques lie beyond BIOTIC's range.

Also beyond BIOTIC's scope are Burggren's second and third hypotheses. The second involves the conservation of oxygen within the lungs (p. 13): "Pulmonary bypass allows 'metering' of lung O<sub>2</sub> store." Essentially, by lowering pulmonary perfusion during apnea (i.e., non-breathing periods), the reptile can slowly release the oxygen as needed during an extended diving episode. First of all, the conservation mentioned by Burggren differs from BTM's conservation in that the former aims at conserving oxygen in the lung, while BTM focuses on conserving entities within the medium/blood. Since blood and lung come into oxygen equilibrium during perfusion, conservation in one generally mirrors conservation in the other. So, although BIOTIC does

not currently handle intra-tissue conservation as a teleology, only small changes would be required to provide such as bias. However, such a focus would greatly alter BIOTIC's teleology-driven evaluations and explanations, by, in many cases, directing the analysis toward a single tissue and its nearest neighboring exchange sites. Also, perhaps the most difficult aspect of Burggren's second hypothesis is the "metering" concept, which requires a much more detailed model of time than possessed by BIOTIC.

In his third hypothesis, Burggren speculates (p. 16), "Pulmonary bypass reduces plasma filtration into lungs." When the lungs receive high perfusion, fluid tends to accumulate in the lungs, especially when ventilation is low and therefore so is the pressure within the lung (whereas high lung pressure normally discourages fluid transfusion into the lung). Fluid in the lungs (also known as pulmonary edema) greatly inhibits the diffusion of oxygen and carbon-dioxide. In the best case, edema reduces transport efficiency; the worst case is death. Hence, it behooves a circulatory system to reduce perfusion during low-ventilation periods.

Once again, BIOTIC only represents this implicitly in the tendency-perfusion-match recommendations of the transport teleology. To accurately simulate edema (and edema prevention), BIOTIC would need to represent fluid as an entity which diffused between the lungs and blood. However, this transfer is based upon hydrostatic and osmotic forces, and not on the concentrations of fluid in the lungs and blood. Hence, as shown by Kuipers and Kassirer (1984), a qualitative simulation of edema demands an integrated model of hydrostatic pressures, oncotic pressures, fluids and entities (i.e., proteins). BIOTIC's foregoes this level of local detail in favor of a more extensive (than Kuipers and Kassirer's) model of global circulatory topology and its effects upon local diffusion behavior.

Finally, BIOTIC's evaluation improves with Burggren's fourth hypothesis: "Left-to-right shunt facilitates CO<sub>2</sub> elimination." During periods of high lung ventilation, a left-to-right shunt favors pulmonary over systemic perfusion and therefore tends to decrease the amount of blood CO<sub>2</sub>. As shown in the previous chapter, BIOTIC can apply first-order CO<sub>2</sub> dissipation to the reptilian complete topology and recognize this advantage of left-to-right shunting. In BIOTIC's terminology, the increased flow to CO<sub>2</sub> consumers combined with the decreased flow to producers facilitates dissipation.

Interestingly enough, Burggren warns that left-to-right shunting during heavy breathing does not enable oxygen accumulation, since oxygen is transported by hemoglobin molecules, which, once saturated, cannot absorb more oxygen even if a favorable oxygen gradient exists between the alveoli and blood. CO<sub>2</sub> diffusion, on the other hand, occurs whenever a gradient exists, since CO<sub>2</sub> transport is much less dependent upon pigments such as hemoglobin. Instead, the majority of CO<sub>2</sub> moves via a reversible chemical reaction with the water in red blood cells. Unfortunately, BIOTIC lacks a sophisticated model of the blood components and their interactions with transported entities. In BIOTIC, diffusion always occurs in the presence of a gradient, thus leading the critic to erroneously recognize left-to-right shunting as an aid to oxygen accumulation.

Finally, in his fifth hypothesis, Burggren focuses on heat-related teleologies (p. 17): "Shunting affects body warming and cooling". Since poikilotherms (i.e., "cold-blooded" animals) cannot produce all of their heat internally, their internal temperatures depend a great deal upon the ambient

temperature. Shunting facilitates the proper utilization of ambient heat with regard to the body's thermal needs. For instance during cooling, a reptile can shunt more blood to the lungs, which generally remove heat from the blood; while on a warm day, if a reptile seeks to increase its body temperature, a right-to-left shunt can reduce pulmonary heat consumption while increasing heat production in tissues near the skin.

As shown in Appendix B, BIOTIC recognizes the advantage of right-to-left shunting during heat accumulation. Heat-related teleologies fit nicely into BTM, since temperature gradients are the primary mechanism of heat transfer. However, the interactions between heat and the diffusion rates of other entities are important physiological realities that exceed BIOTIC's grasp.

In review, BIOTIC captures (a) ventilation perfusion matching and its importance for entity transport, (b) CO<sub>2</sub> dissipation, and (c) temperature-regulation, but it fails to handle (a) energy analyses, (b) entity "metering" teleologies, and (c) edema. These deficiencies all relate to granularity: BIOTIC lacks detailed knowledge about blood constituents, entity interactions, energy and time. Instead, BIOTIC focuses on the spatial relationships between tissues, and how those relations affect exchange behavior. This enables it to recognize some of the advantages and disadvantages of parallel and serial circulations, but only when its simple diffusion model suffices to explain local exchange behaviors.

A more thorough model would include detailed local relationships between and among the diffusion rates of different entities, the hydrostatic and oncotic pressures of capillary blood, the hemoglobin saturation states of that blood, its PH, etc. At a more global level, a sophisticated temporal model would enable reasoning about complex regulatory mechanisms as hinted by Burggren's "oxygen metering" teleology and by Kuipers (1987a) analysis of salt and fluid regulation. As shown below, two local physiologists also addressed the need for greater detail in a BIOTIC.

### Local Physiologists' Critiques

As a second means of evaluating BIOTIC, I interviewed two physiologists at the University of Oregon. To preserve anonymity, I will refer to them as Dr. AP and Dr. EP. Dr. EP specializes in human exercise physiology, while Dr. AP is an expert in animal physiology. I asked them to evaluate the reptilian-complete, mammalian and "strange" topologies (See Appendix C) from both the steady-state and dynamic perspectives, and relative to the oxygen-transport teleology. In addition to their evaluations, the physiologists provided many interesting comments on physiology and modeling. They preferred not to be videotaped. The brunt of our conversation is recorded in scribbled diagrams and notes. Hence, the following is a general description of our discussion and not a transcribed protocol.

Before critiquing the topologies, Dr. EP admitted that he had a hard time viewing things in terms of oxygen transport; he preferred to focus on the maintenance of the oxygen homeostatic balance. Furthermore, he had trouble with the producer-consumer terminology, because to him, the lungs were merely an intermediate transfer site between the atmosphere and the body, not an actual producer of oxygen. But he conceded that from a circulatory-

centered view, the lungs were primarily an oxygen source. Finally, his view of diffusion revolved around Fick's equation, which involves variables such as the permeability and length of the membrane, the molecular weight of the entity, and the cross-sectional area of the diffusion surface, along with the concentration gradient between blood and tissue. This made it very hard for him to discuss simple gradient-based diffusion, because he kept slipping back to the differences in cross-sectional area and permeability of lungs versus muscles, and between different types of muscles.

Dr. AP seemed more willing and able to accept BIOTIC's concepts at face value. He rarely reverted to details beyond those of general circulatory topology and qualitative perfusion and exchange behavior. This, I believe, reflected his general familiarity with a wide variety of circulatory systems.

Dr. EP began his steady-state critiques by stating that reptiles have a great deal more fast-twitch muscle fibers than mammals. This enables them to perform quick, short-duration actions anaerobically (i.e., without oxygen). So, for a reptile, oxygen transport may not be as important a teleology as for mammals. At any rate, assuming oxygen transport as the relevant teleology, Dr. EP criticized the reptile for mixing oxygenated and deoxygenated blood. He then praised the mammalian topology as an excellent oxygen-transport system due to the clean separation of the blood types. Thus he put the mammal above the reptile in terms of static oxygen transport, but he qualified his ranking with the assumption that both mammal and reptile must have the same hemoglobin concentrations.

Dr. AP felt that the mixing aspect of the reptilian topology was an oversimplification, because the timing patterns of the reptiles two atria and single ventricle, along with the ventricle's complex shape, often reduce mixing yet allow the proper blood to shunt to the proper region upon exiting the ventricle. In general, physiologists debate over the degree of reptilian blood mixing. Furthermore, the mixture changes during shunting. For BIOTIC, the concentration of mixed blood is simply "medium" in all cases. Interestingly enough, a modification of the pumping patterns of vein1, vein2 and the reptilian ventricle permit CIRC-SIM to envision a non-mixing reptilian topology, as shown in Appendix D.

The strange topology (see Appendix C) proved more interesting. Its unique arrangement precluded either physiologist from swapping in any previous knowledge of such a system (as both had done in the other two static critiques). Dr. AP tried desperately to relate it to a familiar circulation such as the amphibian's, but he eventually resigned and said, "It's appropriately named." Dr. EP noted that the oxygen producers (i.e., lung and gill) were close to the consumers (i.e., arm, leg and tail). He saw this as an advantage for oxygen transport. Similarly, BIOTIC recognized these direct ties between producers and consumers, as well as reverse lines from consumers to producers.

Dr. EP also stated (erroneously) that blood mixing would decrease the topology's oxygen-transport efficiency. He seemed to associate a single ventricle with mixing blood types (i.e., oxygenated and deoxygenated), regardless of the topology. That view reflected his previous bias toward extant circulations, in which the mixing of blood near or in the ventricle usually involves oxygenated and deoxygenated types. However, in the strange topology, the mixing at T2 involves only deoxygenated blood. Hence, each tissue has an optimal oxygen-exchange gradient.

Dr. EP's most interesting point about the strange topology was that the ventricle was separated from the oxygen producers by consumers. Hence, it would receive little oxygen. He emphasized that the heart was an oxygen consumer, and an important one at that! Dr. EP had not discussed this in previous topologies, but here it was very clear that the ventricle would lack sufficient oxygen unless the arm, leg and tail were all very low consumers. By contrast, BIOTIC does not recognize pumps as consumers and therefore gives the strange topology a perfect static oxygen-transport rating.

Note that in Figure 23, the right ventricle of the mammalian topology also receives deoxygenated blood, which should inhibit its pumping as well. However, in mammals, the two ventricles are contiguous within a single heart. Hence, the oxygenated blood entering the left ventricle supplies oxygen to both ventricles. In all likelihood, Dr. EP did not critique the mammalian topology on the grounds of coronary oxygen supply because he once again imported his knowledge of the real system. Conversely, the strange topology forced him to abandon his preconceptions, revert to first principles, and identify a key topological flaw.

Dr. AP remarked that the serial gill and tail would demand that either the gill work with a low perfusion pressure or the tail work with a high one. Both cases contradict the norm. It was very interesting to see Dr. AP picking apart the topology via his first-principle knowledge of the normal behaviors of individual components (i.e., their prototypical perfusion pressures). Unfortunately, as noted earlier, BIOTIC cannot detect pressure problems within tissues.

In the context of dynamic oxygen transport during underwater diving, Dr. EP chastised the serial nature of the mammalian topology and praised the shunting abilities of the reptile. This led him to rank the reptile above the mammal from the regulatory perspective. However, he added that mammals do have a diving reflex in which (a) heart rate decreases, (b) blood pressure rises, and (c) blood shunts away from the peripheral tissues and toward the brain, lungs and vital organs. Given a modified mammalian circulation, CIRC-SIM can simulate the diving reflex.

Dr. AP noted that during diving, reptiles have a similar reflex in which systemic venous return (i.e., the vein2-to-vent flow in Figure 19) is blocked below the diaphragm. This essentially gridlocks the systemic circulation - allowing blood to freely circulate only to the lungs, vital organs, and brain. To simulate this event, CIRC-SIM would need to shift between flow topologies during regulation. This is an immediate goal of my future research.

Finally, Dr. EP predicted that the strange topology could not sustain any physical activity. He reasoned that any increase in oxygen consumption by the arm, leg or tail would decrease the amount of oxygen available to the ventricle, thus lowering its ability to pump. This, in turn would decrease flow to the active muscle, which would then have to take more oxygen out of each liter of perfusing blood, thereby decreasing, even further, the ventricle's oxygen supply. He concluded that this positive feedback could lead to death. Apparently, to an exercise physiologist like Dr. EP, the strange topology could support nothing more than a couch potato!

Conversely, Dr. AP predicted that in an underwater environment, the strange topology could simply shift to a gill-tail topology and eliminate perfusion to the lung, arm and leg. He noted that such a topology was analogous to that of many fish, and he felt that the fish and mammalian



topologies were equally efficient oxygen-transport systems. He cited the tuna as a prime example of a fish that needs effective oxygen transport since it sustains a metabolic rate similar to that of mammals.

### Interview Summary

The general impression I got from the physiologists was that BIOTIC's models capture a few interesting aspects of circulatory systems but that more detail is needed to improve the accuracy and tutoring potential of the project. Dr. EP was most adamant about BIOTIC's lack of detail. He objected to any circulatory simulation environment in which the component models were not precisely correct. Apparently he wanted quantitative versions of Fick's equation, the Haldane effect, etc. as part of each tissue. He also objected to showing students any topology that did not precisely mirror a living organism. In fact, he was very adamant about placing all cardiac valves inside the ventricles, not alongside, as in the diagrams of this thesis. In short, Dr. EP wanted precision from the component level on up; and his requirements for educational circulatory software ran contrary to a primary goal of the BIOTIC project: to create a simple set of generic components for constructing a wide variety of circulatory topologies, which could then be simulated, evaluated and explained in a qualitative fashion. Dr. EP's software needs would probably be most easily met by a detailed quantitative simulator of a single topology: the human's.

On the other hand, Dr. AP seemed comfortable with generic components that could be configured many different ways. As an animal physiologist, Dr. AP is familiar with a vast array of circulatory systems. Hence, he recognizes topology as a critical aspect to understanding circulatory behavior. Throughout our discussion, Dr. AP added and removed vessels from the strange topology to illustrate key topology-behavior relationships in various organisms such as the hagfish and tuna. Conversely, Dr. EP's elaborations were mainly at the local level.

I initially encouraged each physiologist to critique the topologies using the same primitive behaviors as BIOTIC: static exchange, exchange tendencies, perfusion and perfusion change, etc., as well as similar topological and teleological concepts. However, these proved overly restrictive for both men. Only Dr. AP paid strict attention to topology, and neither physiologist mentioned purpose very often. Dr. EP remarked that he views everything in terms of homeostatic balance, which, to him is the fundamental purpose of all living things. Dr. AP seemed comfortable talking about oxygen transport but never mentioned any other teleologies.

For the most part, the results of these informal interviews were fairly predictable. Each physiologist was very biased toward the circulations he had seen in the past, but when confronted with a novel topology, they both eventually resorted to first principles. His background in comparative physiology made Dr. AP more keenly aware of the topological factors in circulatory behavior, whereas Dr. EP talked more about the intrinsic details of local components and actually made mistakes when talking at the topological level. In short, Dr. AP's analyses seemed much closer in spirit to those of BIOTIC, although Dr. EP did hit on a few excellent topological points.

In the future, I hope to perform a more thorough evaluation of BIOTIC by presenting circulatory models and critical contexts to a dozen or more physiologists - preferably a mix of comparative physiologists (e.g., Dr. AP) and specialists (e.g., Dr. EP). I will abandon the idea of having them speak in BIOTIC's terms and simply ask for evaluations and explanations of each circulatory system's teleological activity in various situations (i.e., environments and tasks). For instance, I might ask them to critique the strange topology's oxygen-transport abilities during diving, but I would not give any detailed explanation of oxygen transport, nor would I attempt to bias their explanations by insisting on a producer-consumer view of circulatory events. Rather, I will just give them the model and the critical context and let them reason freely from there.

Furthermore, the circulatory models will not have meaningful labels such as "reptilian" and "mammalian". This omission should help deter the physiologists from analogizing to known circulations and force them to reason predominantly from first principles.

This more-extensive study should serve as an accurate evaluation of BIOTIC, but most importantly, it should elucidate additional salient first-principles for circulatory analysis. I hope to then formalize many of those principles to form a more solid theoretical foundation for an improved version of BIOTIC.

### Final Impressions

My general conclusion from assessing BIOTIC relative to Burggren, Dr. EP and Dr. AP is that BIOTIC takes an intelligent approach to circulatory criticism, but only from the topological and teleological standpoint. Its simple qualitative components yield it far too general to mimic the analyses of physiologists who specialize in one particular circulatory system. However, for physiologists who do comparative studies, BIOTIC seems to understand enough of their fundamental concepts to output reasonable facsimiles of their critiques. Naturally, Burggren is the best example, since the inspiration for BIOTIC came largely from his paper. The other two physiologists indicated that BIOTIC was on the right track but lacked a host of important details. Many of those details hold considerable promise for future research.

Still, the details that BIOTIC understands are at the first-principle level. This enables BIOTIC to scrutinize any number of novel circulatory topologies without having to draw analogies to familiar topologies (as both Dr. AP and Dr. EP were clearly doing). Surely an analogical component would be welcome in a BIOTIC-like critic, but the analogy problem for complex systems appears far more difficult than any of the problems tackled by this thesis.

It is no profound observation that a robust circulatory critic requires all of the aforementioned capabilities plus many more. Possibly, future research will integrate the predominantly global, topological emphasis of BIOTIC with detailed local structures (advocated by Dr. EP) and temporal models (e.g., those of Kuipers) to produce a highly versatile circulatory simulator. Then, improvements to BTM would support circulatory criticism from a wide spectrum of local, global, temporal, spatial, steady-state and regulatory perspectives.

## CHAPTER VII

### CONCLUSION

The results of this research indicate that qualitative simulation coupled with dual-perspective teleological knowledge is a useful approach to the explanation problem in circulatory physiology. There are many reasons for the relative success of the BIOTIC project:

1. The explicit model of context clarifies the standards by which and situations in which a system can be critiqued.
2. The dual teleological perspectives captures two essential and prevalent modes of purposeful activity.
3. The combination of the producer-consumer bias with that imposed by the four generic teleologies (of BTM) provides a useful framework for pruning and organizing many behaviors and structures into a comprehensive evaluation and explanation.
4. The ability to critique both negative and positive instances of a teleology affords considerable robustness in circulatory analysis. In particular, it enables the criticism of function-sharing systems that embody design compromises to account for each function.
5. BIOTIC integrates three crucial elements of physical-world understanding: structure, behavior and function.
6. The component-based, first-principle nature of BIOTIC supplies the flexibility to analyze many different circulatory systems from a wide variety of contexts.

These features also hold promise for general teleological models. For one thing, bipartite teleology and function sharing are ubiquitous aspects of all organisms and some artifacts. Furthermore, to understand a system often requires the ability to comprehend negative and positive teleological activity. Finally, the generic teleologies of BTM could, with modifications, apply to many other systems, whether physiological, meteorological, hydraulic or thermodynamic. In short, this thesis points the way toward a general model of teleology by capturing a few critical, often-overlooked aspects of purposefulness (albeit, in a specific domain).

The integration of a generic teleological model with a general qualitative simulator (e.g., QSIM or QPE) might then help mount a full-scale attack on the general explanation problem in domains where teleology has significance. This integration would require a means of representing and

operationalizing general purposes within a basic envisioner. Representation seems trivial in comparison to operationalization, which will certainly demand further advances in aggregation, abstraction and other techniques to parse generic structures and behaviors into constructs that highlight a system's functionality. For instance, in BIOTIC, the producer-consumer bias effectively parses each circulatory system into a representation to which BTM applies. A general explanation system would need a great many of these low-level biases to help "set up" their respective higher-level teleologies.

Of course, any discussion of the general explanation problem inevitably contains as much wild speculation as well-founded insight. It is difficult enough just to define explanation! At the very least, this thesis illustrates the extreme importance of a clear and explicit context during the explanation of physical systems; and that insight, if nothing else, certainly pertains to explanation in general.

The next section of this chapter elaborates many of the points listed above in discussing BIOTIC's primary contributions to qualitative physics. It also considers the BIOTIC project and its future implications in light of the three research questions posed at the end of Chapter I. Finally, this thesis concludes with a discussion of future-research possibilities.

### Primary Contributions

The loudest undertone of this work is that teleology is vital to the analysis of complex physical systems. Without teleology, it is very difficult to parse together the myriad behaviors of a complex artifact or organism into a coherent and meaningful picture; and few can debate the importance of these gestalt portraits to one's general understanding of a system.

This is far from a new insight, since teleology has been crucified and resurrected many times throughout the history of science. Some argue that purpose only clouds one's view of behavior and alters one's predictive objectivity, while others see teleology as a framework, not a straight jacket, for hypothesis formation and data interpretation. The computer provides a testing ground for these arguments if we can convert our functional abstractions into LISP.

Just as AI has forced us to formalize goals, constraints, operators, etc. and to clarify their roles in problem solving; qualitative physics now demands a codification of teleology and an investigation into its contribution to physical-system simulation and reasoning. Essentially, QP, like AI, is having trouble fulfilling its promises. A decade ago, QP researchers hinted of applications to complex engineered systems such as steam-generation and nuclear plants; they also boasted of the utility of qualitative relationships in causal explanation - and thus in education. A decade of QP research has now exposed ominous barriers to those dreams such as *ambiguity* and *information overload*. Ambiguity causes envisioners to generate many interpretations, some of which are spurious; it thus betrays the accuracy of qualitative simulation which seems a critical prerequisite to applications in life-threatening situations such as nuclear power plants, medical diagnosis, etc. Information overload, which refers to the plethora of behavioral information output by any simulator (whether qualitative or quantitative), makes explanation a difficult search

task, since many ordered combinations of the same events make enlightening explanations; but without some notion of context, all of these descriptions seem equally informative (or uninformative).

Focus is needed, and as shown by QUAL and BIOTIC, teleology supplies focus in both envisionment pruning and behavioral explanation. Although neither project makes strong psychological claims, both indicate that the combination of qualitative simulation and teleological reasoning suffices to produce intelligent analyses of physical systems. As a result of these projects, qualitative physicists will hopefully gain an appreciation for the power of teleological biases, and, more generally, scientists who promote the use of teleology in scientific reasoning will acquire some operational evidence.

BIOTIC takes the teleology issue one level deeper than QUAL by distinguishing between two perspectives of purposeful behavior: static and dynamic. Philosophers have recognized this distinction, and physiologists have implicitly used it, but qualitative physicists have yet to consider bipartite teleology except in occasional passing comments. Both active and reactive functionality are essential constituents of physical-system understanding. Some systems such as the foundation of a building or the frame of a bicycle achieve most of their purpose via static rigidity, while others such as automatic transmissions, thermoregulators, and kidneys attain teleological significance by reacting to change. But in many systems, particularly physiological ones, both perspectives are prominent. BIOTIC employs both viewpoints to critique circulatory systems.

In addition, BIOTIC supplements teleologies and perspectives with external factors (i.e., the environment and task) to compose a critical context for system evaluation. These contexts clarify the situations and standards for criticism and thereby illustrate the non-absolute, context-sensitive nature of criticism in general. The mammalian and reptilian examples illustrate how different contexts yield vastly different critiques when applied to the same circulatory system. Through these examples, the powerful influence of context upon criticism becomes apparent.

During criticism, BIOTIC shows the utility of teleology in explanation. Basically, a teleology embodies a framework for parsing the interactions between structure and behavior. For instance, a static transport teleology directs the explainer to communication relationships between producers and consumers, while a static dissipative teleology shifts attention to the feedbacks of consumers and producers. The dynamic perspective then merits a completely different explanatory approach via its concern for flowpath relationships and their affects upon perfusion changes dictated by exchange tendencies. I cannot claim that these are the best foci for each explanatory angle, but relative to the teleologies and perspectives of BTM, these foci elucidate the salient connections between structure, behavior and function, which brings me to the fourth contribution of BIOTIC.

This research touches on all three fundamental concepts of qualitative physics: structure, behavior and function. Most previous QP work has neglected the latter, and often (e.g., in the case of simple physical-system simulation) for good reason. However, the qualitative techniques developed for simple systems will not scale up via structure and behavior alone. Teleology is essential. But adding teleology involves much more than simply supplementing an envisioner with a global constraint such as energy conservation, because along with its potential constraints on simulation, a

teleology embodies a viewpoint for evaluation and explanation. Teleology provides expectations by which to understand structure and behavior. Furthermore, in BIOTIC as in QUAL, teleologies primarily act as goals during analysis, not constraints during simulation. Hence, it is important to accurately characterize the relationships between these goals and the structures and behaviors that facilitate or violate them.

Through the evaluation criteria for (a) static exchange behaviors, and (b) dynamic perfusion changes, along with the topological recommendations for static and dynamic functionality, BTM formalizes the interactions between structure, behavior and function. Via BTM, BIOTIC employs teleology as an explicit, fundamentally different type of knowledge, and not as simply an extra global constraint. This distinction is crucial, because, as warned by the No-Function-in-Structure principle, it is all too easy to encode teleology as implicit behavioral constraints.

As a fifth contribution, BIOTIC provides a qualitative producer-consumer model of circulatory systems. The producer-consumer metaphor appears to hold promise for the qualitative modeling of other physiological mechanisms such as the nephritic and digestive systems; and it should extend to other domains such as meteorology, steam-plant engineering, etc. Furthermore, the importance of topology in determining producer-consumer behavior has widespread relevance. For instance, the distance from the top to the bottom of the loop of Henle has considerable impact on the concentration of urine produced by the kidneys, while the spatial relationships between oceans, mountains and plains significantly affect the rainfall (i.e., consumption of water by the earth from the atmospheric cycle) in a particular region.

The producer-consumer metaphor is certainly not new to science, but previous qualitative physics research has not employed it, and probably did not need it. But for BIOTIC, this metaphor was essential for simplifying circulatory behavior down to a level at which the fundamental relationships between structure/topology, behavior and teleology became apparent (both to me and to the computer). The producer-consumer analogy has great explanatory effectiveness.

In a sense, the producer-consumer framework is BIOTIC's implicit teleological bias, because once pulsatile simulation determines the flow topology, the focal components of criticism become the exchange sites, and the focal behaviors of those sites become their exchange rates (regardless of the BTM teleology); all other behaviors are irrelevant. Clearly then, BIOTIC's circulatory understanding rests upon many layers of teleology, only one of which is explicit to the program, and two of which are explicit to me. Other observers may unearth other layers. These BIOTIC-implicit teleologies are certainly not the sparkling gems of this research but merely grim reminders of a third unsolved mystery of qualitative physics: the modeling problem. The modeling of any complex system requires many assumptions, only some of which can be explicated for manipulation by the program. However, as a point in BIOTIC's favor, it has clearly demarcated the next level at which teleological excavation should take place. As discussed more thoroughly in the future-work section, an explicit model of producer-consumerness might pave the way for interesting comparisons between it and other metaphors for circulatory analysis. In effect, the metaphoric interpretation (some may call it the "ontology", while I will just label it as another teleology, since "producer" and

"consumer" have strong functional connotations) could become another component of the critical context.

Finally, this research has considerable potential as an educational application of qualitative physics. In fact, the original motivation for BIOTIC came from our need to produce qualitative explanations of the quantitative simulation results generated by the Cardiovascular Construction Kit (Douglas, 1990). As in that kit, BIOTIC's component-based nature enables users to configure and simulate a wide variety of circulatory models. If supplemented with a graphic interface, BIOTIC could serve as the backbone for an improved biology construction kit through which students could learn the fundamental qualitative relationships between structure, behavior and function in cardiovascular physiology. It might also give students a strong feeling for the context-sensitive nature of scientific analysis and explanation. In short, BIOTIC's robustness should facilitate the hands-on exploration of many aspects of circulatory systems.

In review, the BIOTIC project makes six contributions to qualitative physics. First, and foremost, it formalizes and operationalizes bipartite teleology. Second, it combines bipartite teleology with external factors to codify a critical context for system analysis. Third, it employs that context as a bias during evaluation and explanation - thus illustrating the highly context-sensitive nature of explanation. Fourth, it thoroughly integrates structure, behavior and function while still making each type of information independently accessible to the program. Fifth, it introduces the producer-consumer modeling perspective to qualitative physics. Sixth, BIOTIC's modularity and robustness could help qualitative physics realize some of the educational potential that the field claims to possess. Each of these contributions will be elaborated in connection with the research questions and future work of the upcoming sections.

### Research Questions Revisited

Earlier, I posed three research questions that are addressed by this thesis:

1. First, how does (and how will) teleology assist in the extension of qualitative physics to complex domains?
2. How does teleology's role vary with the computational task (e.g., simulation, diagnosis, recognition, criticism, design)?
3. Can a field of qualitative biology be built from the fundamentals of qualitative physics?

I will now discuss each in turn.

## Scaling Up Qualitative Physics

The extension to complex domains is a central topic in many qualitative physics research circles. Limited progress has been made by Falkenhainer and Forbus (1988) and Collins and Forbus (1987) in thermodynamics, Williams (1985) and de Kleer (1985,1979) in electronics, and Joskowicz (1989) in kinematics. Still, the claim that qualitative physics can apply to truly difficult problems remains largely unsubstantiated. More teleology is clearly needed.

As discussed earlier, the two key roles of teleology in scaling up qualitative physics are as a pruning heuristic for ambiguity reduction, and as a framework for organizing the behaviors of a single *interpretation* into a comprehensive explanation.

BIOTIC manages the complexity of circulatory simulation via the teleological biases of BTM. However, the implicit producer-consumer bias filters a good deal of complexity before BIOTIC even begins. So without an explicit representation of the producer-consumer bias (in the form of a framework used to automatically parse a circulation into a PC network) it is hard to say that BIOTIC explicitly manages an incredibly complex system. Still, it does handle circulatory behavior at the pulsatile, steady-state and regulatory levels, which is a far cry from the ubiquitous springs, heated kettles and bathtubs of most QP research.

Except for the ambiguities of flow envisionment, BIOTIC does not address QP's ambiguity problem. Rather, it focuses on the information overload problem by exploiting teleology to organize the multifarious circulatory behaviors into a coherent description. Of course, teleologies could also be useful in pruning the flow interpretations that most drastically conflict with them. For instance, from the transport angle, a flow pattern that does not perfuse every tissue could be discarded, while a conservation bias might prefer topologies with minimal perfusion. However, such pruning compromises the robustness of criticism, as discussed earlier.

As for the future prospects of scaling up qualitative physics via functional knowledge, bipartite teleology seems critical. Both organisms and artifacts exhibit purposeful behavior from the static and dynamic perspective. Hence, a starting point for exploiting teleology is to segregate (as much as possible) the static and dynamic aspects of a system and then apply the appropriate critical context to each. In BIOTIC, that segregation is fairly simple: concentration gradients are the focus of static criticism, while regulatory analysis deals mainly with perfusion changes.

A good deal of QP research has dealt solely with dynamic analysis; most QP simulators trace the propagation of perturbations but pay little attention to the relationships involved in steady state. However, BIOTIC, along with recent advances by Collins and Forbus (1987) and Throop (1989), recognizes these steady-state relationships as integral aspects of system behavior and function. However, only BIOTIC applies teleology to the static level.

In general, qualitative physics needs a deeper investigation into causality and teleology at the steady-state level. In physiology, structures such as the kidney tubules and circulatory vessels are arranged in very purposeful patterns. Much of that architectural teleology becomes evident only at the static level and is best explained by causal analyses of steady-state behavior.



Similarly, a great many engineered devices such as bridges, chairs and automobile frames also have primarily static purposefulness. However, the rigidity of architecture does not entail static purposefulness, because, as evident in BIOTIC's examples, topology (i.e., a fixed global structure) also plays a major role in regulatory behavior.

In short, an important first step for teleological extensions of qualitative physics involves a more thorough analysis of steady-state causality and purpose. Far too many systems are unsimulatable by QP envisioners, because their salient behaviors lack non-zero temporal derivatives. A system need not be perturbed to be interesting! As QP researchers begin to appreciate this, a greater number of complex systems will succumb to qualitative modeling and simulation.

A second means of advancing QP via teleology is by improving our qualitative feedback models, since regulatory mechanisms generally rely upon feedback loops. De Kleer (1979) and Williams (1985) have shown the importance of feedback recognition and formalization in circuit analysis. BIOTIC, on the other hand, lacks a formal feedback model. It simply employs the BTM's autoregulation heuristics and propagates the changes. However, BIOTIC pays keen attention to the topological factors that inhibit or enable regulatory success. From these, it determines vital relationships between structure and teleology. De Kleer and Williams pay little attention to structure at the physical level; rather, they focus on the structure of mathematical constraints. Surely, a combination of de Kleer and Williams' qualitative feedback models with BIOTIC's topological analysis would greatly improve the quality and depth of teleological analysis. This could be particularly useful for explanation generation, since the mathematics of feedback often becomes more intuitive when juxtaposed with the topological basis for the constraint equations, especially when the critical parameters of the feedback equations occupy different regions of the physical structure.

For instance, consider the condition of pulmonary edema that often follows chronic heart failure in humans, as described by Guyton (1986):

1. A temporarily increased load on the already weak left ventricle results from increased venous return from the peripheral circulation. Because of the limited pumping capacity of the left heart, blood begins to dam up in the lungs.
2. The increased blood in the lungs increases the pulmonary capillary pressure, and a small amount of fluid begins to transude into the lung tissues and alveoli.
3. The increased fluid in the lungs diminishes the degree of oxygenation of the blood.
4. The decreased oxygen in the blood further weakens the heart and also causes peripheral vasodilation.
5. The peripheral vasodilation increases venous return from the peripheral circulation still more.

6. The increased venous return further increases the damming of the blood in the lungs, leading to still more transudation of fluid, more arterial oxygen desaturation, more venous return, and so forth. Thus, a vicious circle has been established. (p. 312)

The qualitative sensitivity graph of Figure 35 models the two positive feedbacks, where a positive feedback is any loop in the sensitivity graph that contains an even number of negative sensitivities. Negative feedbacks contain an odd number of negative sensitivities.

Cardiac failure instigates an initial decrease in cardiac output (i.e., flow out of the left ventricle). It also severely weakens an otherwise strong positive sensitivity of cardiac output to venous return (Hence, that sensitivity does not even appear in the graph). The cardiac-output decline increases pulmonary blood and sets off two deadly feedback loops, both of which continually increases pulmonary fluid and thereby decreases blood oxygenation. The qualitative sensitivities of Figure 35 capture the dynamic causal interactions between parameters. However, the structural topology is also important in understanding the positive feedbacks. Specifically, the serial relationship between systemic and pulmonary regions accounts for the positive sensitivities between (a) venous return and pulmonary perfusion, and (b) pulmonary-blood  $O_2$  and systemic-blood  $O_2$ . Also, it accounts for the strong negative sensitivity of pulmonary perfusion to cardiac output. In the parallel reptilian topology, that sensitivity would weaken, and more importantly, the positive sensitivity of pulmonary perfusion to venous return would disappear to yield the graph of Figure 36.

In Figure 36, note that the positive sensitivity between systemic resistance and pulmonary perfusion converts the larger positive feedback into a negative one. Furthermore, the cardiac output (of the single reptilian ventricle) now has a direct correlation with pulmonary blood (since the ventricle pumps directly into the lungs). This changes the smaller positive feedback into a negative one. These negative feedbacks appear to enhance edema protection in the reptile.

Hence, the basis for the differential structures of the two feedback graphs is topological. In knowing the flowpath relations between the systemic and pulmonary regions, we can understand the structure of the sensitivity graphs, and thereby gain a deeper conceptualization of the feedback behaviors indigenous to regulation. Thus, the combination of BIOTIC's topological information with qualitative feedback models akin to those of de Kleer and Williams promotes a thorough appreciation for the relationships between structure, behavior and regulatory teleology.

In summary, the roles of teleology in advancing qualitative physics into complex domains appear obvious: interpretation pruning and information organizing. To exploit teleology in the latter capacity, we must shore up our notions of static causality and fortify our qualitative regulatory equations with the physical structures that determine them. This should lead to qualitative analyses of complex systems in a manner that thoroughly integrates structure, behavior and function.

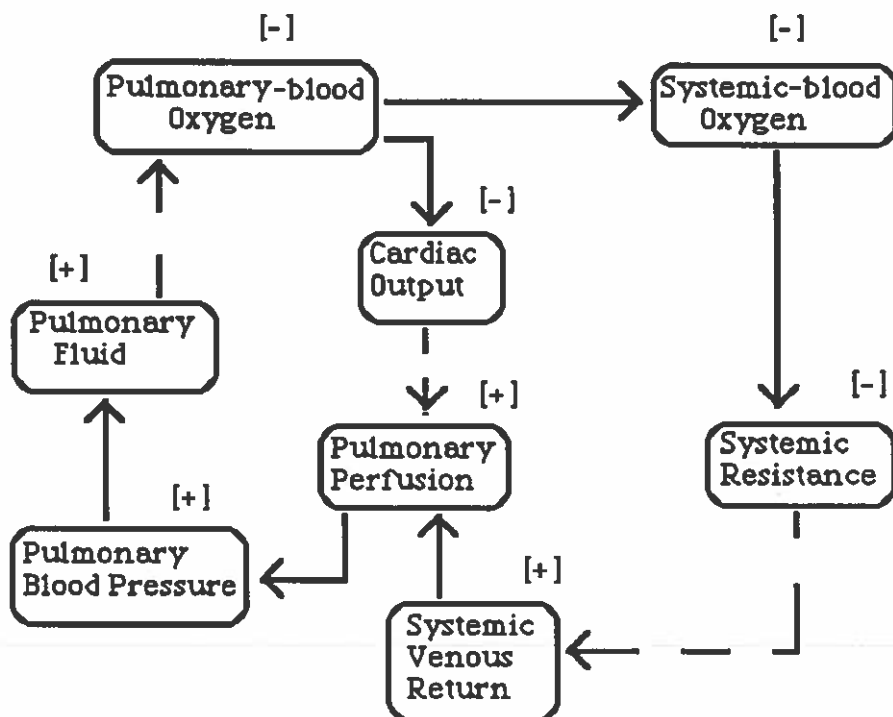

Legend:

A  $\longrightarrow$  B  
B has a positive sensitivity to A

A  $\dashrightarrow$  B  
B has a negative sensitivity to A

[+] positive influence

[-] negative influence

FIGURE 35. Sensitivity graph illustrating positive feedbacks of pulmonary edema in mammal.

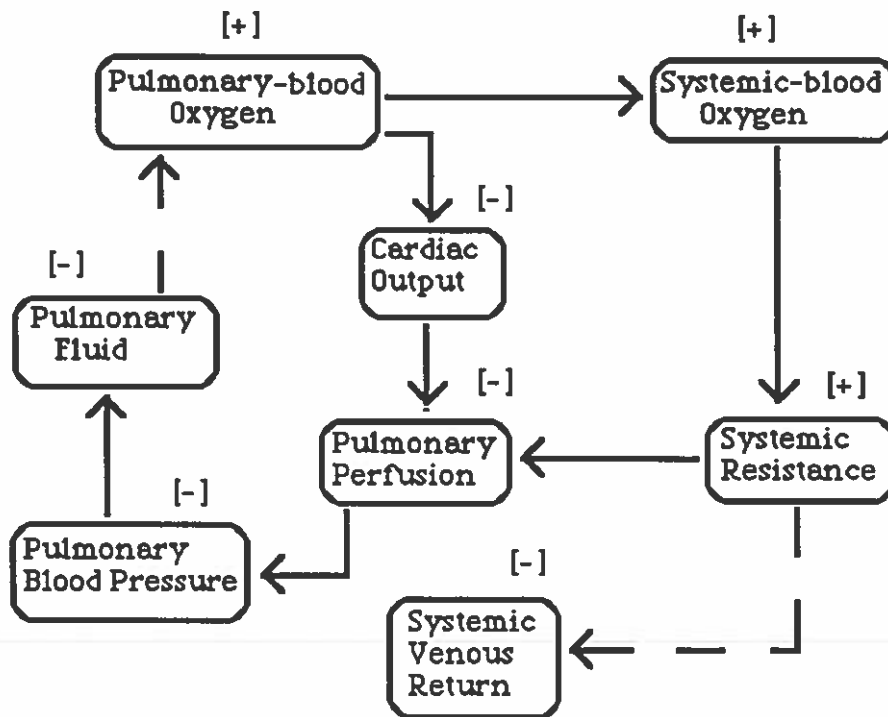

Legend:

A  $\longrightarrow$  B  
B has a positive sensitivity to A

A  $\dashrightarrow$  B  
B has a negative sensitivity to A

[+] positive influence  
[-] negative influence

FIGURE 36. Sensitivity graph showing negative feedbacks of edema protection in reptile.

### Task Sensitivity of Teleological Utility

Different qualitative-physics tasks exploit teleology in different ways. From simulation to recognition to criticism to diagnosis, the characteristics of teleological knowledge, its mode of application, along with its utility, vary considerably. I will now discuss the teleological biases in each of these four tasks.

As warned by No-Function-in-Structure, simulation should not incorporate implicit teleological knowledge, since it compromises robustness.

Theoretically, this is a valid argument, but anyone who has tried to model a complex system (especially qualitatively) realizes the pragmatic impossibilities of NFIS. For instance, BIOTIC requires a teleological bias in the form of autoregulation heuristics (see Table 3), since it lacks a deeper model of the circulation's complex regulatory processes. But such models are elusive. Even physiologists have not discovered all of the pertinent causal mechanisms. Thus, when simulating complex biological systems, one often needs a teleological bias to mimic the homeostatic mechanisms that are either uncodified (by physiologists) or too complex to model explicitly. Granted, this violates NFIS, but without these functional biases, very few biological models could be simulated.

Presumably the need for implicit teleological biases is much lower for the simulation of designed artifacts, since we generally know more precisely how they work. In this case, teleological assumptions may help simplify simulation, but most of them can be represented explicitly and treated as interchangeable pieces of a simulation context, just as Falkenhainer and Forbus (1988) use behavioral factors to define a context, and BIOTIC uses bipartite teleology and environment as a context.

In short, the temptation and/or need to violate NFIS is ubiquitous. For the simulation of any complex system, functional assumptions are prerequisites. In the best case, the program can explicitly manipulate these assumptions, while in other situations, they may remain implicit but hopefully will not compromise robustness within a behavioral range of relevance to the user. For instance, a cardiologist may accept simplified, functionally biased models of the brain but demand a detailed, relatively unbiased heart model. In general, the practical gains of NFIS violations often far outweigh the theoretical losses.

NFIS changes its tune once envisionment finishes: de Kleer and Brown (1983) praise functionality as a means of parsing device behaviors. Both QUAL and BIOTIC manifest this teleological virtue. As detailed earlier, the task of recognition enables de Kleer to use teleology as an envisionment pruner, while the attempt to provide robust criticisms precludes such a practice in BIOTIC. Whereas QUAL simply discards interpretations that violate the teleology, BIOTIC evaluates and explains those "negative instances". This stems from the differing demands of recognition and criticism. As mentioned earlier, a recognition system looks for any interpretation that supports a teleology; in this sense, it assumes the correctness of at least one interpretation. A critic, takes the opposite viewpoint by assuming that most, if not all, interpretations will violate the teleology. The critic must then explain the failure. De Kleer admits that explanations of negative instances would be a useful (but nonessential) enhancement of QUAL. Conversely, a robust critic must necessarily analyze and explain most or all interpretations.

Unfortunately, this is more a theoretical than a practical point in the current implementation of BIOTIC. Since it only deals with ambiguity during flow envisionment, BIOTIC's robustness comes solely from a multitude of possible flow topologies, and not from possible exchange behaviors within those topologies, since BIOTIC computes exactly one global exchange pattern for each topology. Hence, BIOTIC does not create huge interpretation tables akin to QUAL's, although in the case of many pumps and strange pumping patterns, it can envision quite a few flow topologies; and it can critique every one of them relative to many critical contexts!

The different uses of teleology in QUAL versus BIOTIC stems not only from the recognition-criticism distinction but also from the domain differences. In electronics, circuits are frequently designed for precisely one purpose (e.g., amplification). Any components or behaviors that do not contribute to that purpose signify a flaw, and any interpretations in which such deficiencies occur are probably not the correct ones. On the other hand, a physiological system performs many diverse functions. Hence, the view from any one teleological angle may highlight flaws, that, from a different angle, represent teleology-supporting evidence. In other words, a complex system may integrate many teleological mechanisms, but function sharing is rarely so perfect as to render each behavior helpful (or at least innocuous) relative to every salient teleology. Within many critical contexts, small problems will appear; but these need not signal failure. In fact, they may not even signal inefficiency, since the system may embody a nice compromise between a host of pressing teleologies. In short, the multiple functions of physiological systems preclude the use of "exact-match" criteria during teleology-based envisionment pruning, regardless of whether the task is recognition or criticism.

To continue our inter-task comparison, diagnosis also exploits teleology, but at a more local level than that of a structure critic such as BIOTIC. Diagnosis typically involves reasoning from symptomatic behaviors to faulty structures/components under the assumption that if all components work properly, then the system will serve its purpose. Hence, teleological satisfaction is equivalent to the state in which every system component exhibits its "normal" behavior. In the search for symptoms, the diagnostic process uses these normal modes as standards for behavioral comparison. In medical diagnosis, for example, the observation that blood pressure is "high" implies that it exceeds the standard level normally required for proper body functioning. Empirical evidence determines that normal value, and since almost all humans possess the same circulatory topology, a doctor can base most diagnoses upon that value. In essence, the teleological bias maps straight to the component level, because diagnosis generally assumes a proper system configuration (e.g., a correct topology) but admits local structural failures.

Furthermore, when the system components have fairly context-independent normal modes, diagnosis does not even require an explicit high-level teleology. For instance, in digital electronics we always expect an "and" gate to output a "1" if and only if it receives two "1"s as inputs. Unlike an exchange site in BTM, the "most desirable" behavior of an "and" gate does not fluctuate according to any global teleologies. Furthermore, the fixity of normal modes generally scales up to a constant global teleology; e.g., the circuit performs correct arithmetic. Since they never change, these ubiquitous global teleologies can be implicitly encoded in the diagnostic system and need never be reasoned about by the program. The fact that model-based diagnostic systems such as GDE (de Kleer and Williams, 1987), DART (Genesereth, 1985) and DIAGNOSE (Reiter, 1987) can perform successfully without high-level teleological knowledge represents a strong domain dependence, since all three systems have been tested primarily on digital electronics problems.

In short, automated diagnosticians can get by without explicit teleological knowledge in either of two cases:

1. When proper topology is taken for granted, global teleological expectations compile directly into local behavioral goals and obviate any further need for high-level purposive knowledge during either the testing or explaining phases of diagnosis.
2. When local "normal" modes are context independent, a single global teleology generally covers all situations and can therefore be encoded directly into the diagnostician.

In contrast, a structure critic must often assume that all components are behaving properly in order to determine flaws in their topological relationships. Therefore, the critic often focuses on groups of components as it searches for topological segments that violate the intended purpose. Individual components can still be "held responsible" for problems, but usually by virtue of their relative locations rather than their independent behaviors. For instance, in the reptilian topology, BIOTIC does not blame the lung for its low steady-state oxygen-production rate. Instead, it blames the blood mixing caused by the parallel topology. Conversely, a diagnostic system would tend to focus on local pulmonary features such as the lungs internal oxygen concentration, or the oxygen-permeability of its alveoli.

Basically, the critic cannot easily "farm out" the responsibility of satisfying the teleology to the individual components (as in diagnosis), because their topological organization may preclude the attainment of the functional goal, regardless of their individual behaviors. Although the critic may localize a problem to a component, and base its evaluation upon local behaviors (as in BIOTIC), nothing guarantees that changes to that component will rectify the situation. For instance, in a BIOTIC-like situation, if a lung is positioned immediately downstream from a ventricle, the high pressure may flood the alveoli with water (i.e., cause edema). The system will therefore "break" in the lung, and the critic must go to the component level to recognize that fault; but it should not simply suggest the replacement of the lung with an edema-resistant version. Rather, the critic should take a more global perspective and realize that the problem stems from the proximity of ventricle and lung. This should lead it to recommend the addition of resistant vasculature between the two components. So, the critic may compile the teleology into local tests, but structural improvement demands more than simple local therapy and hence requires repeated consultation with the high-level functional criteria. Alternatively, diagnosticians, particularly of designed artifacts, can generally remedy any situation by simply replacing a broken part.

In summary, the utility of teleological knowledge varies across QP tasks. Whereas in practice, simulation generally requires many implicit functional assumptions, NFIS scorns such a bias. However, when it comes to analyzing behaviors in recognition, criticism and diagnosis, teleology plays a vital role in providing a standard for subjective interpretation; and NFIS has no objections. In diagnosis, that subjectivity generally compiles into simple normality tests, while recognition and criticism often require the program to have explicit representations of global teleologies and their concomitant local recommendations. In short, teleology is an important and unavoidable factor in many subfields of qualitative physics. In many cases, we can get by without explicit program-manipulable functional models, but as qualitative physics advances into more complex domains, implicit teleologies will eventually have

to surface if we expect the robustness of QP tasks to keep pace with the escalating ambiguities and information overloads (i.e., many behaviors within a single *interpretation*) of those domains.

### Qualitative Biology

Previously, the techniques of qualitative physics have been applied primarily to either simple physical phenomena or man-made artifacts; biology and medicine have received little attention. However, researchers who apply AI to medicine have begun looking to the first-principles of qualitative physics as possible solutions to their modeling problems; and a few qualitative physicists have turned to biology as an intriguing new domain. Still, biology is not simply another domain. The simulation, diagnosis, etc. techniques of QP are not equally well applicable to digital electronics and renal physiology; and by the same token, BIOTIC does not directly generalize to weather patterns and steam plants. Of course, the gaps between any two domains often prohibit direct technology transfers, but the chasm between the physical and biological sciences is particularly ominous. In the next few pages, I will discuss a few important differences between physics and biology, and between the prototypical physical and biological situations tackled by AI practitioners. This will illuminate a few key research areas for spanning the chasm.

First of all, biological analyses are extremely dependent upon context, whereas physics frequently abstracts away everything but the essential local factors. As quoted in Chapter I, Ernst Mayr (1988), the famous evolutionary biologist, recognizes the extreme time and space-boundedness of biological investigation, while physical principles are presumably the same here on earth in 1990 as in any other part of the space-time continuum. Biological principles do not vary across time or space, but an organism's environment and evolutionary history are critical aspects to fully understanding its form and function. Physical-system analyses are generally far less context sensitive, especially when it comes to history.

However, both environmental and historical context can play a role in analyzing designed artifacts. For instance, state-of-the-art inventions such as the aforementioned "smart bricks", along with skin-like sensors, computerized automobile engines, and other advanced regulatory systems are very sensitive to the environment. Hence, automated analyses of such devices must possess an explicit environmental model. Regarding history, one can often gain a thorough appreciation for a device by comparing it to historical predecessors. So, physical artifacts are certainly not devoid of historical context, but whole sciences are not built around comparing past to contemporary models, as in evolutionary biology.

In sum, the concept of context is vital to biological understanding and potentially very useful in analyzing engineered artifacts. The proposed field of qualitative biology must include fairly sophisticated models of context, especially during tasks such as criticism. Without context, biological criticism reverts back to "gold standard" comparison and the temptation of the anthropocentric bias.

BIOTIC's critical contexts represent a reasonable start by capturing the teleology, perspective, environment and task. However, critical contexts



neglect history, whose addition would enable BIOTIC to take a more active role in comparing physiological models, especially those representing evolutionary lineages. Furthermore, BIOTIC cannot handle transitions between contexts, which is certainly vital to understanding the physiologies of organisms such as reptiles, amphibians and snakes, which may frequently alternate between aquatic, terrestrial and arboreal environments. Basically, BIOTIC assumes "rest" is the normal state, and the perturbations inherent in all other environments and tasks are relative to rest; but "rest" is only a task. What is the resting environment? Land? Water? Air? Obviously, normal states are difficult to define in any absolute sense; they depend upon the organism. Also, it is hard to make accurate qualitative statements about an environments concomitant physiological perturbations (e.g., pulmonary oxygen goes up at high altitude) unless we know the previous context of the system (e.g., lower altitude). BIOTIC's assumption that the previous context was "normal resting" is fairly undesirable due to the organism-dependence of that state.

The deficiencies in BIOTIC's critical contexts highlight a key point: qualitative biological analysis not only demands a model of context, but a mechanism for context shifting as well. Formal context-management systems such as the ATMS (de Kleer, 1986) may prove useful in this regard.

A second interesting distinction between the demands of physical and biological modeling is one of robustness. Physical sciences such as electronics focus on both individual components or mechanisms and their many global configurations. An electrical engineer can look at many circuits and make well-founded behavioral predictions about every one. Biologists, particularly medical professionals, learn many local structures and behaviors, but usually in the context of the human body. Hence, medical education involves a strong NFIS violation, which may severely limit a student's ability to reason about diverse physiological configurations.

Animal physiologists or veterinarians may study many organisms, but a lot of the basic structure is the same. For instance, most mammals have identical circulatory topologies. In general, physiologists are frequently familiar with only a handful of configurations, which they can count on seeing time and time again. Consequently, they can often compile their knowledge into associations between non-proximal parameters, as was done in the edema models presented earlier. These compiled associations enable the physiologist to circumvent first-principle reasoning during system analysis. However, this also implies that physiological reasoning requires less first-principle adeptness, especially since the justifications for many parameter association are purely empirical. In general, the specialized demands of medical education along with the relative homogeneity of the vital systems of many organisms decreases the demand for robust first-principle reasoning that is indigenous to many physical domains.

Hence, qualitative biology may require less of the analytical reasoning of qualitative physics but an improved ability to compile first principles into useful global associations. In cardiology, the KARDIO (Bratko, Mozetic and Lavrac, 1986) and QUALSA (Downing, 1987) projects have made nominal progress in that direction.

In light of biology's inherent nonrobustness, BIOTIC provides a very unique environment for learning biological phenomena, since its component-based, toolkit nature enables users to configure topologies that may never appear in living organisms. Part of the learning experience is to understand

precisely why certain topologies would not enable survival. The critic's explanations provide useful comments along those lines.

As indicated above, the ideal qualitative physiology system should include a toolkit for constructing a wide variety of topologies, and a knowledge-compilation engine for determining the salient global parameter associations. Then, enlightening sensitivity graphs similar to the edema models presented earlier could be generated for a host of existing and imaginary physiological systems. This would offer the dual benefits of robust first-principle simulation followed by critical analyses that highlight salient parameter relationships, whether local or global.

A third essential difference between physical and biological systems concerns regulatory mechanisms. Homeostasis is the mainstay of life. Without the ability to adjust to perturbations, an organism becomes a slave to its environment in the sense that the full effect of an exogenous factor is felt by the organism (i.e., no buffering of inputs). Homeostatic mechanisms help an organism to maintain the values of certain critical internal variables within a tight range even though external conditions may fluctuate wildly. For instance, thermal regulation facilitates the maintenance of a liveable internal temperature when the environmental temperature far exceeds or undercuts the desirable internal value. As shown by BIOTIC, the regulation of blood flow (and the oxygen, carbon dioxide and nutrients it brings) to tissue beds during activities such as swimming and running is also an essential element of survival.

Conversely, even some fairly complex engineered artifacts lack regulatory abilities. Bridges, cars, houses, stereos, automatic garage door openers, etc. are all designed to efficiently achieve a set of teleologies, but only very advanced models (or experimental AI versions) have the ability to independently adjust to environmental perturbations. For instance, the roundness and rubber composition of car tires statically supports the teleology of fast movement over many types of terrain, but those tire properties do not change in response to the terrain. When roads become very snowy, the automobile cannot put on its own tire chains. However, the automatic transmission enables it to shift gears in response to changing speeds; and newer models can adjust to skidding by automatically shifting into four-wheel drive. In many cases, engineers integrate regulatory mechanisms into artifacts only to save their operators a lot of work. Organisms operate themselves and therefore need those mechanisms on board.

Kuipers (1987b) recognizes the ubiquity of regulatory mechanisms as a fundamental distinction between electrical and physiological systems. He uses QSIM to represent the intertwined mechanisms of water and salt regulation in the blood (1987a). However, his models, like those of BIOTIC, do not explicitly represent the salient feedbacks. In reading textbooks and conversing with physiologists, I have learned that truly informative qualitative simulations of biological mechanisms must have a formal and explicit homeostatic model that governs many low-level behaviors. Unfortunately, in BIOTIC, this is no trivial supplement. Without the ability to compile out the critical feedback variables from a connected set of local components, BIOTIC cannot hope to discern the salient global regulatory mechanisms. Instead, it relies on a simple set of regulatory heuristics designed to mimic the local physiological process of autoregulation. On the other hand, Kuipers models global regulatory

mechanisms as basic constraints, since QSIM pays no attention to the local or global nature of its parameter associations.

This presents a fundamental dilemma in qualitative biological modeling: if we choose a component-based approach to modeling, as in QUAL or BIOTIC, we often miss crucial global relationships, especially when the user is free to create a variety of topologies. BIOTIC recognizes certain global structures, such as parallel or serial tissues, and global behaviors, such as flows; but it misses important non-local feedback relationships similar to those in the edema sensitivity graphs. Hence, in qualitative physiology, a component-based modeling paradigm may provide a robust simulation environment at the expense of missing or undetected global regulatory mechanisms. On the other hand, a constraint-based modeling perspective that disregards the physical structure (e.g., QSIM) can represent these mechanisms, but it misses the relevant topological nuances that are fairly explicit in a component-based approach. And as discussed earlier, topology is often a critical factor in understanding feedback and regulation.

This leads us to a final important aspect of biological systems: topology. As the contrast between mammalian and reptilian circulations indicates, the structural topology often determines the efficacy of regulatory and steady-state activity. In their famous paper, "Behavior, Purpose and Teleology", Rosenblueth, Wiener and Bigelow (1966) compare living organisms to man-made artifacts and notice that machines tend to utilize large differences in potential to quickly mobilize large amounts of energy, while animals and plants can achieve only small local gradients and concomitantly slower and smaller local energy/mass transfers. However, the spatial aggregation and crafty configuration of many such low-powered mechanisms enables organisms to perform large global transfers.

In the kidneys, the loop of Henle is a textbook example of an ingenious topology. Salt pumps within the kidney can actively transport solute against no more than a 200 mosm gradient, which would seem to prevent the kidney from attaining more than a 200 mosm gradient between its internal environment and the perfusing fluid. However, by stringing together a long series of these salt pumps and then bending it into a "U" shaped channel, evolution has crafted a mechanism for achieving osmolarity gradients bounded only by the height of the "U". These high osmolarity gradients enable the kidneys to excrete heavily concentrated urine and to thereby conserve water. Hence, it is no surprise that desert animals often have considerably longer loops of Henle (i.e., higher "U"s) than organisms of other climates.

This indicates that qualitative biological systems need to capture topological information in order to convey the essential underpinnings of many behaviors. In BIOTIC, topological information arises from explicit physical structure, but in QSIM, "structure" is nothing more than a set of qualitative differential equations (with respect to time). However, Throop (1989) has recently modified QSIM to also simulate change with respect to space. This facilitates causal reasoning (which usually requires some notion of change) about steady-state physiological mechanisms, such as the countercurrent multiplication that occurs in the loop of Henle. Hence, Throop's work helps integrate qualitative physics and biology by formalizing a model of spatial change, which in turn enables him to recognize interesting behaviors in steady-state systems.

BIOTIC continues along the lines of Throop by focusing on spatial relationships from both regulatory and steady-state perspectives. Additionally, BIOTIC injects teleology into physiological reasoning to organize and provide a motivation for the behaviors of these systems. This elicits the functional significance of the topologies underlying those behaviors.

In short, spatial reasoning is an important component of a qualitative biology system, since organisms often achieve critical behaviors through ingenious topologies. Furthermore, spatial reasoning enables us to detect causality during steady-state; this supports causal explanation in the absence of temporal change. BIOTIC and Throop's research should provide springboards for future investigation into topological concerns in qualitative biology.

### BIOTIC. Biology and Physics

I would now like to take a wide-angle view of BIOTIC and its implications for the development of qualitative biology from qualitative physics. Consider the relationships between qualitative physics, qualitative biology and circulatory criticism. Qualitative methods possess great potential in both physics and biology. In the last decade, great strides have been made in qualitative physics, but the contemporary structure-behavior myopia demands an infusion of teleology to boost qualitative physics above the complexity level of pendulums, springs and bouncing balls. Meanwhile, the successes of qualitative physics: envisioning techniques, semantics for causality, data interpretation methods, models of naive physics, qualitative mathematics, etc., have yet to find widespread application in biology. Possibly the ambiguities of qualitative simulation prove too risky for medical applications; and maybe first-principle reasoning has little worth to medical practitioners, who often put their trust in empirical data and its compiled abstractions. Still, many biology textbooks teach basic biological principles and the causal interactions of physics and chemistry that determine organic behavior. This importance of basic principles and causal models indicates that, at the very least, biology education could benefit from qualitative simulation and reasoning methodologies.

Now consider circulatory criticism, a biological task that (a) seems well grounded in the qualitative first principles of flow and diffusion, and (b) demands a clear model of teleology (and environment). These features indicate that circulatory criticism should help link qualitative physics to biology to form a bi-directional pathway for their mutual enrichment. Namely, the application of qualitative physics techniques to circulatory criticism, via BIOTIC, gives some indication of their general use in other biological situations, especially since many biological systems rely on the fundamental processes of flow and diffusion. Furthermore, physiological criticism ties more closely to biology education (e.g., comparative physiology) than to medical diagnosis or therapy. Hence, qualitative techniques applied to criticism pose no threat to lives, but instead help elucidate the fundamental interconnections between structure, behavior and purpose that are so essential to understanding organic systems.

Going the other direction, the Bipartite Teleology Model should point the way to more general teleological models in qualitative physics, since many

inorganic systems also rely on flow and diffusion, or, more generally, upon some delivery mechanism routed between components (e.g., a copying machine or a steam-generation plant). In short, the specialized task of circulatory criticism has widespread implications for the integration of two important fields. BIOTIC and BTM hint of the potential fruits of this interdisciplinary pursuit.

### Future Research

From the beginning of my investigation into the teleological aspects of physiology, many interesting problems have been considered and discarded due to lack of time or personal insight. Furthermore, the implemented BIOTIC system has deficiencies that should form the basis for interesting future work. This section examines at a few of those overlooked issues, while others have already been discussed as answers to the previous three questions.

### Temporal Models

BIOTIC's temporal model is relatively weak. It deals with pumping histories at the pulsatile level, but static and regulatory analyses proceed without temporal concerns. While the steady-state view requires no temporal reasoning, regulatory analysis often does. For instance, Kuipers (1987a) notes the disparity in timescales of the human body's arterial-pressure-regulating mechanisms. Baroreceptors and chemoreceptors kick in seconds after blood pressure changes, but other mechanisms such as vasoconstriction and renal activities take minutes or hours to activate.

Since BIOTIC relies on a single regulatory mechanism, autoregulation, timescales would not appear to be important. However, the environmental factors often affect perturbations over different timescales. For instance, underwater diving creates a fairly immediate change in pulmonary oxygen concentrations of an air-breathing organism; and dives usually only last a few minutes. Conversely, a move to high altitude often occurs over hours or days (in the case of a long mountain climb), and one may remain at high altitude for days or even years. In this case, the regulatory changes are more permanent, such as an enlargement of the heart and lungs, an increase in hemoglobin, etc. So in general, timescale models seem very important for physiological simulators that handle a diversity of situations through a variety of mechanisms.

### Teleological Models

BIOTIC models four generic teleologies from two different perspectives. A more robust teleological model might include more generic teleologies, more abstraction levels of those teleologies, and more perspectives from which to examine teleological activity. For instance, we could enhance the generic

teleology set with a heat-pump teleology, which demands both heat transport and work output.

Concerning teleological levels, I previously discussed the importance of explicating the producer-consumer bias and making it one of a collection of high-level teleologies for analyzing physiological systems. Another interesting abstract teleology is the descending-gradient view, in which, for instance, the purpose of the circulatory system is to maintain a descending oxygen gradient from the atmosphere to the lungs, to the circulation to the systemic tissues. The consensus functional view of the loop of Henle also conforms to the descending gradient model.

At a lower level, the "roles" assigned to components during pulsatile abstraction have certain teleological connotations. However, the relative simplicity of these roles makes this less interesting than in QUAL (de Kleer, 1979), where, for instance, a common resistor may assume one of 18 roles. In BIOTIC, no component may assume more than 4 roles, and most components assume the same role across all flow interpretations. However, if more detail were added to BIOTIC's component models, then all components could presumably take on many roles, and role assignment would become a more interesting phase of teleological parsing. Nonetheless, local role assignments, which de Kleer calls "the implementation teleology" are important building blocks for higher-level teleological analysis.

A third dimension of teleological enhancement is the perspective. It seems reasonable that bipartite teleology might generalize to n-partite teleology, or at least to tripartite teleology. In the tripartite case, BIOTIC would include second-order analysis in which regulatory mechanisms oversee other regulatory mechanisms. These meta-regulators would evaluate the performance of first-order regulators and adjust them accordingly. For instance, consider the autoregulatory heuristic of decreasing flow to a tissue that has a tendency of decreased production when the teleology is transport. If this rule fails to enhance transport in a number of situations, the meta-regulator might change the recommendation to an increase in flow. In this way, second-order regulatory mechanisms would embody "learning" at the physiological level. These higher-level regulators might represent global homeostatic controllers such as the central nervous system and hypothalamus.

### Inter-Topology Comparison

Another form of circulatory regulation involves topology shifting. For instance, the crocodilian circulation often shifts from the serial to parallel topology during diving. This enhances oxygen transport in bypassing the low-production lung. BIOTIC needs to (a) recognize potential topology shifts and (b) compare the two topologies to discern the qualitative perfusion changes. However, when topologies change, so do local concentration gradients. Hence, criticisms based solely on perfusion changes may be less convincing than those generated during intra-topology regulation. In other cases, the topologies may be so radically different as to yield comparative perfusion estimates equally ambiguous. Still, the fixity of the component topology should provide enough stable ground for inter-topology analyses.

As simulated by Farley (1988), topology shifts are standard behaviors in complex hydraulic systems. Furthermore, de Kleer (1979) discusses the importance of capturing electrical topology changes, although QUAL cannot handle them. But, Farley and Liu (1990) have simulated topology shifts in component-based electrical models. Still, little has been done in comparing the latter topology to its predecessor in order to assess the significant qualitative changes incurred by the shift.

### Comparative Physiology

One step beyond inter-topology analysis lies comparative physiology, wherein the same physiological systems of different organisms are juxtaposed. An operationalization of this task would enable BIOTIC to compare two distinct circulatory systems and pinpoint the critical topological relationships that distinguish them behaviorally and teleologically. This might enable BIOTIC to criticize one system by drawing analogies to another - as was done by Dr. AP in evaluating the *strange* topology.

Comparative physiology is a biological field unto itself. BIOTIC was inspired by the comparative physiology literature, and BIOTIC's generality enables one to investigate many circulatory models; but all of the comparisons are left to the user. Any automation of this endeavor would have considerable educational value, and it would probably provide interesting insights into research areas such as analogy and comparative analysis.

### Further Integration

Although BIOTIC has combined structure, behavior and function; further integration of these and other aspects of qualitative reasoning is needed to continue the advance of qualitative physics into complex domains. For instance, a tighter intertwining of local and global information would enable component-based simulations to avoid many of the ambiguities incurred by pure local reasoning. Furthermore, if global sensitivities can be compiled directly from local constraints, critical high-level feedback relationships may become explicit in even the most novel configurations. Also, these high-level associations would permit reasoning akin to that of physiologists and others who become very familiar with a particular topology.

As detailed earlier, structural knowledge should be integrated into feedback models to fortify the explanations of regulatory mechanisms. BIOTIC explains how topology contributes to local regulation, but further work is needed provide a structural basis for explanations of global feedback-related behaviors such as pulmonary edema.

## Educational Applications

The component-based, first-principle nature of BIOTIC should support a rich learning environment for circulatory physiology. At the University of Oregon, we have already designed the Cardiovascular Construction Kit, which includes a quantitative cardiovascular simulator, a circulatory construction kit, and a friendly graphic interface that allows students to build a circulatory topology and observe its behavior expressed as both animated graphics and qualitative graphs of variables (Douglas, 1990). Students are then free to query the system as to the values and value histories of parameters; and in some cases, the system provides explicit causal explanations (Douglas and Liu, 1989). However, these explanations are pure behavioral traces of perturbation propagation.

If enhanced with a graphic interface, BIOTIC could supplement the Cardiovascular Construction Kit by teaching the basic teleological and topological concepts of circulatory physiology, along with the behaviors. This would inspire the kind of gestalt system understanding that only comes from the thorough integration of structure, behavior and purpose.

---

## Other Domains

BIOTIC and BTM were designed for circulatory criticism. However, the fundamental concept of bipartite teleology should apply to a vast array of domains such as meteorology, hydraulics, thermodynamics, etc. The producer-consumer metaphor on which BTM rests is similar to the "piece-of-stuff" reasoning applied by Collins and Forbus (1987) to generalized fluid-flow systems. BTM injects teleology into piece-of-stuff reasoning to improve the automated explanations of such systems. Furthermore, BTM should work with other mediums such as the gas in respiratory channels or pneumatic artifacts.

In addition, future applications to teleology-laden domains could benefit from BTM's general paradigm for formalizing and exploiting teleology. To wit, teleologies compile into local behavioral expectations and global structural recommendations, both of which strongly bias evaluation and explanation. Furthermore, reaction heuristics based on teleology can facilitate regulatory simulation when one lacks (or prefers not to use) a complex model of the actual regulatory process. In biology, many of these regulatory mechanisms have yet to be discovered.

This work has formalized teleology in a domain where they are omnipresent but implicit. Many other domains, particularly those in the natural sciences, have similar tacit teleologies that govern the predictions, analyses and explanations of their practitioners. It is in those domains that the spirit of the BIOTIC project can most fruitfully continue.



## BIBLIOGRAPHY

- Braithwaite, R. (1966). Causal and teleological explanation. In J. Canfield (Ed.), Purpose in nature (pp. 17-26). Englewood Cliffs, NJ: Prentice Hall.
- Bratko, I., Mozetic, I., & Lavrac, N. (1986). Automatic synthesis and compression of cardiological knowledge. Machine Intelligence, 11, 45 - 61.
- Burggren, W. (1987). Form and function in reptilian circulations. American Zoologist, 27, 5-19.
- Campbell, K. (1979). Heart-artery interaction and cardiac output. Western Veterinarian, 17, 16-20.
- Collins, J., & Forbus, K. (1987). Reasoning about fluids via molecular collections. Proceedings of The Sixth National Conference on Artificial Intelligence (pp. 590-594). Seattle, Washington: Morgan Kaufmann Publishers, Inc.
- DeCoste, D. (1989, August). Dynamic across-time measurement interpretation. Paper presented at the Qualitative Physics Workshop, Palo Alto, CA.
- De Kleer, J. (1979). Causal and teleological reasoning in circuit recognition (Tech. Rep. No. 529). Boston: Massachusetts Institute of Technology Artificial Intelligence Laboratory.
- De Kleer, J. (1985). How Circuits Work. In D. Bobrow (Ed.), Qualitative reasoning about physical systems (pp. 205-280). Amsterdam, The Netherlands: Elsevier Science Publishers B.V.
- De Kleer, J. (1986). An assumption-based truth maintenance system. Artificial Intelligence, 28(2), 127-162.
- De Kleer, J., & Brown, J. (1983). Assumptions and ambiguities in mechanistic mental models. In D. Gentner & A. Stevens (Eds.), Mental models (pp. 155-190). Hillsdale, New Jersey: Erlbaum.
- De Kleer, J., & Brown, J. (1985). A qualitative physics based on confluences. In D. Bobrow (Ed.), Qualitative reasoning about physical systems (pp. 7-84). Amsterdam, The Netherlands: Elsevier Science Publishers B.V.

- De Kleer, J., & Williams, B. (1987). Diagnosing multiple faults. Artificial Intelligence, 32(1), 97-130.
- Dennett, D. (1978). Intentional systems. In D. Dennett (Ed.), Brainstorms (pp. 3-22). Cambridge, Massachusetts: The MIT Press.
- Dietterich, T., & Buchanan, B. (1981). The role of the critic in learning systems (Tech. Rep. No. 891). Palo Alto, CA: Stanford University Department of Computer Science.
- Douglas, S. (1990). The cardiovascular construction kit: Experiments in object-oriented and knowledge-based instructional simulation. Unpublished manuscript, University of Oregon, Eugene, OR.
- Douglas, S., & Liu, Z. (1989). Generating causal explanation from a cardio-vascular simulation. Proceedings Eleventh International Joint Conference on Artificial Intelligence (pp. 489-494). Detroit, Michigan: Morgan Kaufmann Publishers, Inc.
- Downing, K. (1987). Diagnostic improvement through qualitative sensitivity analysis and aggregation. Proceedings of The Sixth National Conference on Artificial Intelligence (pp. 789-793). Seattle, Washington: Morgan Kaufmann Publishers, Inc.
- Downing, K., & Shrager, J. (1988). Causes to clauses: Managing assumptions in qualitative medical diagnosis. International Journal of Artificial Intelligence in Engineering, 3(4), 192-199.
- Eckert, R., Randall, D., & Augustine, G. (1988). Animal physiology. New York: W.H. Freeman and Company.
- Falkenhainer, B., & Forbus, K. (1988). Setting up large-scale qualitative models. Proceedings of the Seventh National Conference on Artificial Intelligence (pp. 301-306). St. Paul, MN: Morgan Kaufmann Publishers, Inc.
- Farley, A. (1988). Cluster-based representation of hydraulic systems. Proceedings of Fourth Conference on Artificial Intelligence Applications (pp. 358-364). San Diego, CA: Morgan Kaufmann Publishers, Inc.
- Farley, A., & Liu, Z. (1990). Automated analysis of physical systems from multiple perspectives. Unpublished manuscript, University of Oregon, Eugene.
- Fikes, R., & Nilsson, N. (1971). STRIPS: A new approach to the application of theorem proving to problem solving. Artificial Intelligence, 2, 189-208.

- Forbus, K. (1983). Measurement interpretation in qualitative process theory. Proceedings of The National Conference on Artificial Intelligence (pp. 315-320). Washington, D.C.: University of Maryland.
- Forbus, K. (1985). Qualitative process theory. In D. Bobrow (Ed.), Qualitative reasoning about physical systems (pp. 85-168). Amsterdam, The Netherlands: Elsevier Science Publishers B.V.
- Forbus, K. (1986a). Interpreting observations of physical systems (Tech Rep. No. 1248). Urbana-Champaign: University of Illinois Department of Computer Science.
- Forbus, K. (1986b). The qualitative process engine (Tech. Rep. No. 1288). Urbana-Champaign: University of Illinois Department of Computer Science.
- Forbus, K., & Gentner, D. (1986a). Causal reasoning about quantities. Proceedings of the Eighth Annual Conference of the Cognitive Science Society (pp. 196-207). Amherst, Mass, Hillsdale: Lawrence Erlbaum.
- Forbus, K., & Gentner, D. (1986b). Learning physical domains. In R. Michalski, J. Carbonell & T. Mitchell (Eds.), Machine learning: An artificial intelligence approach, 2 (pp. 311-348). Los Altos, CA: Morgan Kaufmann Publishers, Inc.
- Genesereth, M. (1985). The use of design descriptions in automated diagnosis. In D. Bobrow (Ed.), Qualitative reasoning about physical systems (pp. 411-436). Amsterdam, The Netherlands: Elsevier Science Publishers B.V.
- Gould, S. (1983). Agassiz in the Galapagos. In S. Gould (Ed.), Hen's teeth and horses toes (pp. 107-119). NY: WW Norton & Company, Inc.
- Guyton, A. (1986). Textbook of medical physiology. Philadelphia, PA: W.B. Saunders Company.
- Hempel, C. (1966). The logic of functional analysis. In J. Canfield (Ed.), Purpose in nature (pp. 89-108). Englewood Cliffs, NJ: Prentice Hall.
- Johnson, L. (1986). Intention-based diagnosis of novice programming errors. Los Altos, CA: Morgan Kaufmann Publishers, Inc.
- Joskowicz, L. (1989). Simplification and abstraction of kinematic behaviors. Proceedings of the Eleventh International Joint Conference on Artificial Intelligence (pp. 1337-1342). Detroit, MI: Morgan Kaufmann Publishers, Inc.

- Kuipers, B. (1985). Commonsense reasoning about causality: Deriving behavior from structure. In D. Bobrow (Ed.), Qualitative reasoning about physical systems (pp. 169-204). Amsterdam, The Netherlands: Elsevier Science Publishers B.V.
- Kuipers, B. (1986). Qualitative simulation. Artificial Intelligence, 29(3), 289-338.
- Kuipers, B. (1987a) Abstraction by time-scale in qualitative simulation. Proceedings of The Sixth National Conference on Artificial Intelligence (pp. 621-625). Seattle, WA: Morgan Kaufmann Publishers, Inc.
- Kuipers, B. (1987b) Qualitative simulation as causal explanation. IEEE Transactions on Systems, Man, and Cybernetics, 17(3), 432-444.
- Kuipers, B., & Berleant, D. (1988). Using incomplete quantitative knowledge in qualitative reasoning. Proceedings of the Seventh National Conference on Artificial Intelligence (pp. 324-329). St. Paul, MN: Morgan Kaufmann Publishers, Inc.
- Kuipers, B., & Chiu, C. (1987). Taming intractable branching in qualitative simulation. Proceedings of The Tenth International Joint Conference on Artificial Intelligence (pp. 1079-1086 ). Milano, Italy: Morgan Kaufmann Publishers, Inc.
- Kuipers, B., & Kassirer, J. (1984). Causal reasoning in medicine: Analysis of protocol. Cognitive Science, 8, 363-385.
- Lee, W., & Kuipers, B. (1988). Non-intersection of trajectories in qualitative phase space: A global constraint for qualitative simulation. Proceedings of the Seventh National Conference on Artificial Intelligence (pp. 286-290). St. Paul, MN: Morgan Kaufmann Publishers, Inc.
- Mayr, E. (1988). Cause and effect in biology. In (Ed. Mayr, E.) Toward a new philosophy of biology (pp. 24-37). Cambridge, MA: The Belknap Press of Harvard University Press.
- Nagel, E. (1966). Teleological explanation. In J. Canfield (Ed.), Purpose in nature (pp. 67-88). Englewood Cliffs, NJ: Prentice Hall.
- Reiter, R. (1987). A Theory of diagnosis from first principles. Artificial Intelligence, 32(1), 57-96.
- Rosenblueth, A., Wiener, N., & Bigelow, J. (1966). Behavior, purpose, and teleology. In J. Canfield (Ed.), Purpose in nature (pp. 9-16). Englewood Cliffs, NJ: Prentice Hall.

- Sacerdoti, E. (1974). Planning in a hierarchy of abstraction spaces. Artificial Intelligence, 5, 115-135.
- Seymour, R. (1987). Scaling of cardiovascular physiology in snakes. American Zoologist, 27, 97-109.
- Simmons, R. (1988). A theory of debugging plans and interpretations. Proceedings of the Seventh National Conference on Artificial Intelligence (pp. 94-99). St. Paul, MN: Morgan Kaufmann Publishers, Inc.
- Simmons, R. (1986). Commonsense arithmetic reasoning. Proceedings of The Fifth National Conference on Artificial Intelligence (pp. 118-124). Philadelphia, PA: Morgan Kaufman Publishers, Inc.
- Skorstad, G., & Forbus, K. (1989). Qualitative and quantitative reasoning about thermodynamics. Paper presented at the Qualitative Physics Workshop, Palo Alto, CA.
- Stallman, R., & Sussman, G. (1977). Forward reasoning and dependency-directed backtracking in a system for computer-aided circuit analysis. Artificial Intelligence, 9, 135-196.
- Struss, P. (1988). Global filters of qualitative behaviors. Proceedings of the Seventh National Conference on Artificial Intelligence (pp. 275-279). St. Paul, MN: Morgan Kaufmann Publishers, Inc.
- Sussman, G. (1975). A computer model of skill acquisition. New York: American Elsevier.
- Taylor, R. (1966). Comments on a mechanistic conception of purposefulness. In J. Canfield (Ed.), Purpose in nature (pp. 17-26). Englewood Cliffs, NJ: Prentice Hall.
- Throop, D. (1989). Spatial unification: Qualitative spatial reasoning about steady state mechanisms. Paper presented at the Qualitative Physics Workshop, Palo Alto, CA.
- Turner, J. (1987). The cardiovascular control of heat exchange: Consequences of body size. American Zoologist, 27, 69-79.
- Weld, D. (1988). Comparative analysis. Artificial Intelligence, 36(3), 333-374.
- Williams, B. (1985). Qualitative analysis of MOS circuits. In D. Bobrow (Ed.), Qualitative reasoning about physical systems (pp. 281-346). Amsterdam, The Netherlands: Elsevier Science Publishers B.V.
- Williams, B. (1986). Doing time: Putting qualitative reasoning on firmer ground. Proceedings of The Seventh National Conference on

Artificial Intelligence (pp. 105-112). Philadelphia, PA: Morgan  
Kaufman Publishers, Inc.

## APPENDIX A

## PRODUCER-CONSUMER TOPOLOGIES

A Producer-Consumer (PC) Topology for a flow topology consists of a Role Network (RN) and a Global Tissue Hierarchy (GTH). This appendix presents the RN's (see Tables 21 and 22) and GTH's (see Tables 23 - 26) for the reptilian and mammalian topologies.

Role Assignments for the Flow Topologies

TABLE 21. Role Assignments for Reptilian Topologies

Component	Systemic	Complete	Pulmonary
V1	-----	Conduit	Conduit
V2	-----	Conduit	Conduit
V3	-----	Conduit	Conduit
V4	Conduit	Conduit	-----
V5	Conduit	Conduit	-----
V6	Conduit	Conduit	-----
T1	Conduit	Splitter	Conduit
T2	Conduit	Mixer	Conduit
T3	Splitter	Splitter	-----
T4	Mixer	Mixer	-----
T5	-----	Splitter	Splitter
T6	-----	Mixer	Mixer
VV1	Conduit	Conduit	Conduit
VV2	Conduit	Conduit	Conduit
VV3	-----	Conduit	Conduit
VV4	-----	Conduit	Conduit
VV5	Conduit	Conduit	-----
VV6	Conduit	Conduit	-----
Vent	Sender/Receiver	Sender/Receiver	Sender/Receiver
Vein1	-----	Sender/Receiver	Sender/Receiver
Vein2	Sender/Receiver	Sender/Receiver	-----
M1	Diffuser	Diffuser	-----
M2	Diffuser	Diffuser	-----
L1	-----	Diffuser	Diffuser
L2	-----	Diffuser	Diffuser

TABLE 22. Role Assignments for  
Mammalian Topology

Component	Role
V1	Conduit
V2	Conduit
V3	Conduit
V4	Conduit
V5	Conduit
V6	Conduit
T1	Splitter
T2	Mixer
T3	Splitter
T4	Mixer
VV1	Conduit
VV2	Conduit
VV3	Conduit
VV4	Conduit
RV	Sender/Receiver
LV	Sender/Receiver
Vein1	Sender/Receiver
Vein2	Sender/Receiver
M1	Diffuser
M2	Diffuser
L1	Diffuser
L2	Diffuser

### Global Tissue Hierarchies

The notation  $PTU_x[y,z]$  denotes a parallel tissue unit beginning at a splitter,  $x$ , and having tissue aggregates (i.e. a tissue or group of tissues)  $y$  and  $z$  as its two branch sub-hierarchies.



TABLE 23. GTH for Reptilian Systemic Topology

Characteristic Flows	Tissue Hierarchy
Vent -> Vein2 Vein2 -> Vent	PTU <sub>T3</sub> [M1, M2] -----

TABLE 24. GTH for Reptilian Complete Topology

Characteristic Flows	Tissue Hierarchy
Vent -> (Vein1, Vein2)	PTU <sub>T1</sub> [PTU <sub>T3</sub> , PTU <sub>T5</sub> PTU <sub>T3</sub> [M1, M2] , PTU <sub>T5</sub> [L1, L2]
Vein1 -> Vent	-----
Vein2 -> Vent	-----

TABLE 25. GTH for Reptilian Pulmonary Topology

Characteristic Flows	Tissue Hierarchy
Vent -> Vein1 Vein1 -> Vent	PTU <sub>T5</sub> [L1, L2] -----

TABLE 26. GTH for Mammalian Topology

Characteristic Flows	Tissue Hierarchy
LV -> Vein2	PTU <sub>T3</sub> [M1, M2]
Vein2 -> RV	-----
RV -> Vein1	PTU <sub>T1</sub> [L1, L2]
Vein1 -> LV	-----

## APPENDIX B

## SUN-BASKING REPTILE

To simulate a reptile warming itself via sun-bathing, BIOTIC employs the following critical context:

(Complete-Topology Heat-Accumulation Warm-Air Resting).

Unlike entities such as oxygen and carbon-dioxide, whose producers and consumers do not change (very much) across tasks or environments, heat exchanges vary with the situation. In general, lungs are heat consumers. Elevated breathing increases pulmonary heat consumption, which explains why dogs pant on hot days. However, muscles may produce or consume heat depending upon the environment: in a warm climate, they produce, while cooler temperatures inspire consumption.

Due to this uncertainty over local heat exchange, BIOTIC cannot make static critiques relative to the temperature teleologies unless the environment is included in the context. Furthermore, relative to heat, environments do not exert primitive influences (i.e. they do not affect heat derivatives) but instead determine the zero-order qualitative heat concentrations of all "external" tissues (i.e. those close to the skin, which, in BIOTIC, includes all muscles and gills). This explains why the tendencies of the four tissues in Table 27 are all steady. The explanation then appears in Figures 37 and 38.

TABLE 27. Dynamic Evaluation of Heat Accumulation in Sun-Basking Reptile

Tissue	Tendency	Telco-based Flow Change	Actual Flow Change	Telco-Based Rating
L1	Steady Csm	Decr	Incr	1
L2	Steady Csm	Decr	Incr	1
M1	Steady Prod	Incr	Decr	1
M2	Steady Prod	Incr	Decr	1
Global Evaluation:				1.0

Local Resistance Influences:

- 1) The "resting" activity exerts no activity-level influences.
- 2) The teleology of heat accumulation causes:
  - a)  $\partial R(\text{Lung1})[+1]$
  - b)  $\partial R(\text{Lung2})[+1]$
  - c)  $\partial R(\text{M1})[-1]$
  - d)  $\partial R(\text{M2})[-1]$

Parallel Tissue Unit Interactions:

- 1) At  $\text{PTU}_{T3}$ ,  $\partial R(\text{M1})[-1]$  and  $\partial R(\text{M2})[-1]$  cause:
  - a)  $\partial R(\text{PTU}_{T3})[-1]$
  - b)  $\partial \text{Dist}(\text{PTU}_{T3}, \text{M1})[0]$
  - c)  $\partial \text{Dist}(\text{PTU}_{T3}, \text{M2})[0]$
- 2) At  $\text{PTU}_{T5}$ ,  $\partial R(\text{Lung1})[+1]$  and  $\partial R(\text{Lung2})[+1]$  cause:
  - a)  $\partial R(\text{PTU}_{T5})[+1]$
  - b)  $\partial \text{Dist}(\text{PTU}_{T5}, \text{Lung1})[0]$
  - c)  $\partial \text{Dist}(\text{PTU}_{T5}, \text{Lung2})[0]$
- 3) At  $\text{PTU}_{T1}$ ,  $\partial R(\text{PTU}_{T3})[-1]$  and  $\partial R(\text{PTU}_{T5})[+1]$  cause:
  - a)  $\partial R(\text{PTU}_{T1})[0]$
  - b)  $\partial \text{Dist}(\text{PTU}_{T1}, \text{PTU}_{T3})[+1]$
  - c)  $\partial \text{Dist}(\text{PTU}_{T1}, \text{PTU}_{T5})[-1]$

Pump-Output Influences:

- 1)  $\partial R(\text{PTU}_{T1})[0]$  causes  $\partial \text{Flowout}(\text{Vent})[0]$

Local Perfusion Influences:

- 1)  $\partial \text{Flowout}(\text{Vent})[0]$ ,  $\partial \text{Dist}(\text{PTU}_{T1}, \text{PTU}_{T5})[-1]$ , and  $\partial \text{Dist}(\text{PTU}_{T5}, \text{Lung1})[0]$  cause  $\partial \text{Perfusion}(\text{Lung1})[-1]$
- 2)  $\partial \text{Flowout}(\text{Vent})[0]$ ,  $\partial \text{Dist}(\text{PTU}_{T1}, \text{PTU}_{T5})[-1]$ , and  $\partial \text{Dist}(\text{PTU}_{T5}, \text{Lung2})[0]$  cause  $\partial \text{Perfusion}(\text{Lung2})[-1]$
- 3)  $\partial \text{Flowout}(\text{Vent})[0]$ ,  $\partial \text{Dist}(\text{PTU}_{T1}, \text{PTU}_{T3})[+1]$  and  $\partial \text{Dist}(\text{PTU}_{T3}, \text{M1})[0]$  cause  $\partial \text{Perfusion}(\text{M1})[+1]$
- 4)  $\partial \text{Flowout}(\text{Vent})[0]$ ,  $\partial \text{Dist}(\text{PTU}_{T1}, \text{PTU}_{T3})[+1]$  and  $\partial \text{Dist}(\text{PTU}_{T3}, \text{M2})[0]$  cause  $\partial \text{Perfusion}(\text{M2})[+1]$

FIGURE 37. Causal trace of regulatory behavior in sun-basking reptile.

In the causal trace of Figure 37, notice that "resting" does not exert any activity-level influences. In BIOTIC, resting is the steady-state at which all activity levels are normal. Conversely, the task of "hibernation" exerts negative influences upon all tissue activity levels.

Next, BIOTIC recognizes the significance of the parallel pulmonary and systemic regions, as shown in Figure 38.

1. Group (Lung1 Lung2) with the tendency of steady consumption has a direct parallel flowpath relationship to Group (M1 M2), which has a tendency of steady production. This *satisfies* the teleology-recommended *parallel* relationship (from Table 5).
2. Group (Lung1, Lung2) with a desired decrease in perfusion and an actual decrease in perfusion has a direct parallel flowpath relationship to Group (M1 M2), which has a desired increased perfusion rate and an actual increase in perfusion. This is an example of a *parallel relationship enabling disparate flow demands*.

FIGURE 38. Structural justification of regulatory behavior in sun-basking reptile relative to the heat-accumulation teleology.

Notice that the behaviors, evaluations and explanations of the sun-basking reptile are the mirror image of those for the heavy-breathing reptile. In effect, heat accumulation via sun-basking involves a right-to-left shunt, while CO<sub>2</sub> dissipation during heavy breathing requires a left-to-right shunt.

## APPENDIX C

## THE STRANGE TOPOLOGY

The strange topology (see Figure 39) is an example of a novel circulatory topology that BIOTIC can simulate and critique. It consists of a gill, lung, arm, leg and tail, which are separated into two parallel regions, both of which have producers and consumers in series. Hence, it should inherit some of the advantages of both serial and parallel topologies. Unfortunately, as evident during regulatory analyses, it also inherits some of the drawbacks.

The strange topology's global tissue hierarchy (GTH) appears in Table 28, while Table 29 contains the strange topology's evaluation for the four static oxygen teleologies.

TABLE 28. GTH for the Strange Topology

Characteristic Flows	Tissue Hierarchy
Vent -> (Vein1, Vein2)	PTUT1[STUGT, STULAL] STUGT[Gill, Tail] STULAL[Lung, PTUT3] PTUT3[Arm, Leg]
Vein1 -> Vent	-----
Vein2 -> Vent	-----

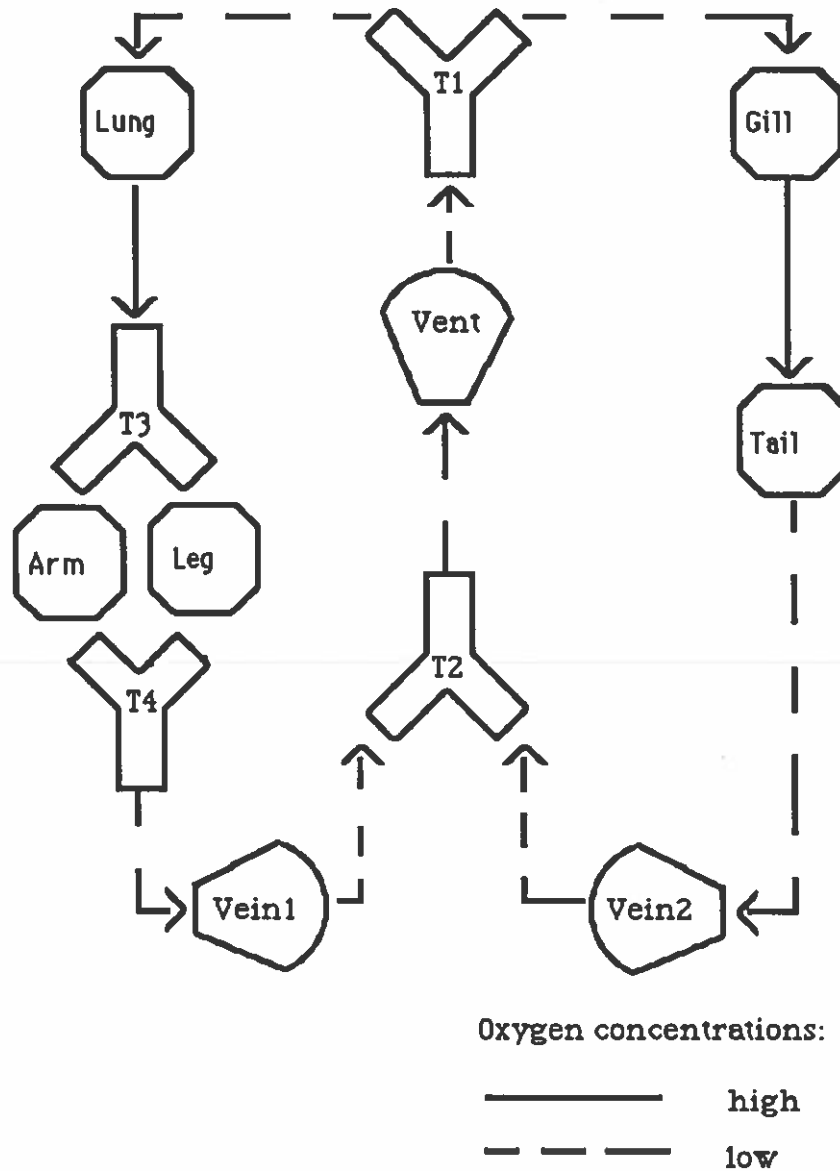

FIGURE 39. The strange topology.

The results of Table 28 are based on the assumption that both the gill and lung can operate during steady state. This implies that the gill is submerged in water, while the lung has access to air.

TABLE 29. Static Evaluations of the Strange Topology  
Relative to the Four Oxygen Teleologies

Comp	[O2]-in	[O2]-st	Grad	Exchg	Trans	Cons	Diss	Accum
Arm	High	Low	High Neg	High Csmg	1	-1	0.5	0
Leg	High	Low	High Neg	High Csmg	1	-1	0.5	0
Lung	Low	High	High Pos	High Prod	1	-1	0	0.5
Gill	Low	High	High Pos	High Prod	1	-1	0	0.5
Tail	High	Low	High Neg	High Csmg	1	-1	0.5	0
Global Evaluation:					1.0	-1.0	0.3	0.2

As an accompaniment to the evaluations of Table 29, the static explanation relative to oxygen transport (see Figure 40) praises the pure feeds of each tissue:



**Priority Level 1:**

Oxygen Transport recommends that producers have pure consumer feed.

Evaluation: SAT

Satisfiers:

Lung - fed by Arm, Leg and Tail (all consumers)

Gill - fed by Arm, Leg and Tail (all consumers)

Violators: nil

Oxygen Transport recommends that consumers have pure producer feed.

Evaluation: SAT

Satisfiers:

Tail - fed by Gill

Arm - fed by Lung

Leg - fed by Lung

Violators: nil

**Priority Level 2:**

Oxygen Transport recommends that producers have no feedback.

Evaluation: SAT

Satisfiers:

Lung, Gill - neither have feedback

Violators: nil

Oxygen Transport recommends that consumers have no feedback.

Evaluation: SAT

Satisfiers:

Arm, Leg, Tail - none have feedback

Violators: nil

**FIGURE 40.** Explanation of strange topology relative to static oxygen transport.

As Table 30 indicates, the dynamic evaluation of the Strange Topology lags behind the perfect static-oxygen-transport evaluation. The explanation of these behaviors then appears in Figures 41 and 42.

TABLE 30. Evaluation of Strange Topology Relative to Dynamic Oxygen Transport During Underwater Diving

Tissue	Tendency	Teleo-based Flow Change	Actual Flow Change	Teleo-Based Rating
Arm	Incr CsmP	Increase	Steady	0
Leg	Std CsmP	Steady	Decrease	0
Lung	Decr Prod	Decrease	Decrease	1
Gill	Incr Prod	Increase	Increase	1
Tail	Incr CsmP	Increase	Increase	1
Global Evaluation:				0.6

Local Resistance Influences:

- 1) The task of diving and its activity-level changes cause:
  - a)  $\partial R(\text{Arm})[-1]$
  - b)  $\partial R(\text{Lung})[+1]$
  - c)  $\partial R(\text{Tail})[-1]$
  - d)  $\partial R(\text{Gill})[-1]$
- 2) The oxygen-transport teleology causes:
  - a)  $\partial R(\text{Leg})[0]$

Parallel Tissue Unit Interactions:

- 1) At  $\text{PTUT}_3$ ,  $\partial R(\text{Leg})[0]$  and  $\partial R(\text{Arm})[-1]$  cause:
  - a)  $\partial R(\text{PTUT}_3)[-0.5]$
  - b)  $\partial \text{Dist}(\text{PTUT}_3, \text{Arm})[0.5]$
  - c)  $\partial \text{Dist}(\text{PTUT}_3, \text{Leg})[-0.5]$
- 2) At  $\text{PTUT}_1$ ,  $\partial R(\text{STUGT})[-2]$  and  $\partial R(\text{STULAL})[0.5]$  cause:
  - a)  $\partial R(\text{PTUT}_1)[-0.75]$
  - b)  $\partial \text{Dist}(\text{PTUT}_1, \text{STUGT})[1.25]$
  - c)  $\partial \text{Dist}(\text{PTUT}_1, \text{STULAL})[-1.25]$

Serial Tissue Unit Interactions:

- 1) At  $\text{STUGT}$ ,  $\partial R(\text{Tail})[-1]$  and  $\partial R(\text{Tail})[-1]$  cause:
  - a)  $\partial R(\text{STUGT})[-2]$
- 2) At  $\text{STULAL}$ ,  $\partial R(\text{Lung})[+1]$  and  $\partial R(\text{PTUT}_3)[-0.5]$  cause:
  - a)  $\partial R(\text{STULAL})[0.5]$

Pump-Output Influences:

- 1)  $\partial R(\text{PTUT}_1)[-0.75]$  causes  $\partial \text{Flowout}(\text{Vent})[0.75]$

Local Perfusion Influences:

- 1)  $\partial \text{Flowout}(\text{Vent})[0.75]$  and  $\partial \text{Dist}(\text{PTUT}_1, \text{STUGT})[1.25]$  cause:
  - a)  $\partial \text{Perfusion}(\text{Gill})[+2]$
  - b)  $\partial \text{Perfusion}(\text{Tail})[+2]$
- 2)  $\partial \text{Flowout}(\text{Vent})[0.75]$  and  $\partial \text{Dist}(\text{PTUT}_1, \text{STULAL})[-1.25]$  cause:
  - a)  $\partial \text{Perfusion}(\text{Lung})[-0.5]$
- 3)  $\partial \text{Flowout}(\text{Vent})[0.75]$  and  $\partial \text{Dist}(\text{PTUT}_1, \text{STULAL})[-1.25]$  and  $\partial \text{Dist}(\text{PTUT}_3, \text{Arm})[0.5]$  cause:
  - a)  $\partial \text{Perfusion}(\text{Arm})[0]$
- 4)  $\partial \text{Flowout}(\text{Vent})[0.75]$  and  $\partial \text{Dist}(\text{PTUT}_1, \text{STULAL})[-1.25]$  and  $\partial \text{Dist}(\text{PTUT}_3, \text{Leg})[-0.5]$  cause:
  - a)  $\partial \text{Perfusion}(\text{Leg})[-1]$

FIGURE 41. Causal trace of regulatory behavior for strange topology during diving.

Figure 41 provides the basic causal explanation of the Strange Topology during diving, while Figure 42 supplies a structural justification in terms of the salient parallel and serial relationships. As shown by the second interesting relationship of Figure 42, the problem with the Strange Topology during diving is that the leg demands a steady perfusion rate, while the lung's perfusion should decrease (due to the absence of underwater air). However, since the tissue lie in non-absolute series, it is difficult to satisfy their different flow demands. Conversely, on the other side, the gill and tail both require increased perfusion; and their serial relationship facilitates the mutual satisfaction of both demands.

1. Lung, with the tendency of *decreased production* has an *non-absolute serial flowpath relationship* with Leg, which has a tendency of *steady consumption*. This *partially satisfies* the teleology-recommended parallel relationship.
2. Lung, with a desired *decrease* in perfusion and an actual *decrease* in perfusion has a *non-absolute serial flowpath relationship* to Leg, which has a desired *steady* perfusion rate and an actual *decrease* in perfusion. This is an example of a *serial relationship deterring disparate flow demands*.
3. Gill, with a desired *increase* in perfusion and an actual *increase* in perfusion has an *absolute serial flowpath relationship* to Tail, which has a desired *increased* perfusion rate and an actual *increase* in perfusion. This is an example of a *serial relationship enabling common flow demands*.
4. Lung, with the tendency of *decreased production* has an *non-absolute serial flowpath relationship* with Arm, which has a tendency of *increased consumption*. This *partially satisfies* the teleology-recommended parallel relationship.
5. Group (Gill Tail) with a desired *increase* in perfusion and an actual *increase* in perfusion has an *indirect parallel flowpath relationship* to Lung, which has a desired *decreased* perfusion rate and an actual *decrease* in perfusion. This is an example of a *parallel relationship enabling disparate flow demands*.

FIGURE 42. Structural justification of regulatory behaviors in strange topology during diving.

## APPENDIX D

## SERIALIZING THE REPTILIAN CIRCULATION

Given the following pumping pattern:

Vent: ((R 1 2) (C 3 4) (R 5 6) (C 7 8) (R 9 10) (C 11 12) (R 13 14) (C 15 16))

Vein1: ((R 1 4) (C 5 8) (R 9 12) (C 13 16))

Vein2: ((C 1 4) (R 5 8) (C 9 12) (R 13 16))

and initial pump amounts:

Vent: Empty

Vein1: Empty

Vein2: Full

CIRC-SIM generates 9 flow topologies based on the possible pump-strength relationships between Vein1 and Vent, and Vein2 and Vent. For all interpretations in which  $\text{Strength}(\text{Vein1}) \geq \text{Strength}(\text{Vent})$  and  $\text{Strength}(\text{Vein2}) \geq \text{Strength}(\text{Vent})$ , the resulting topology is that of Figure 43. Notice that this topology should have perfect static-oxygen-transport rating. In fact, the serial reptilian topology has exactly the same evaluations, and almost identical explanations, as those of the mammalian topology across all four static oxygen teleologies. Also, the regulatory critiques for diving and heavy breathing in the serial reptilian topology are nearly equivalent to those of the mammal.

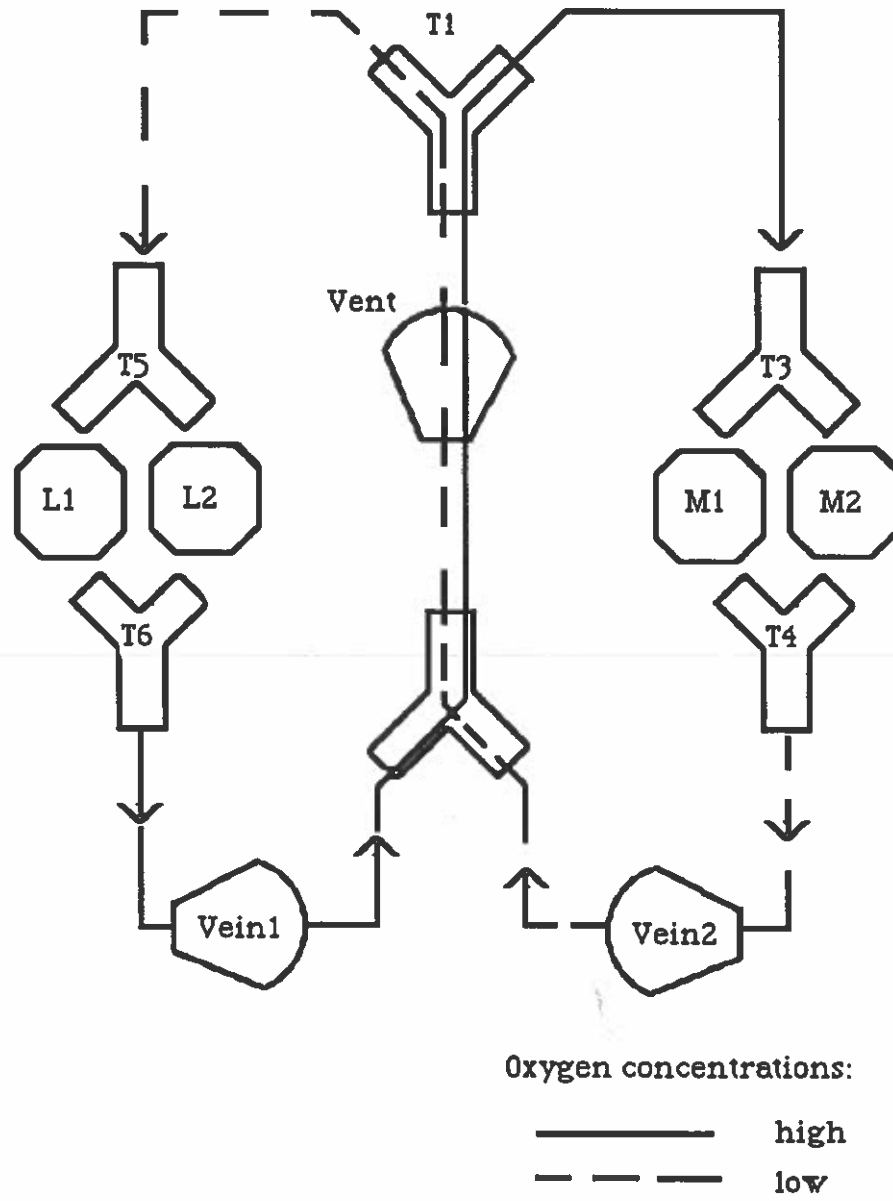

FIGURE 43. The serial reptilian topology.